



SERVICE MANUAL

ZHP SERIES

Inverter Single Zone Ductless Mini-Split

Model

ZHP06SA-1

ZHP09SA-1

ZHP12SA-1

ZHP15SA-1

ZHP18SA-1

ZHP24SA-1



A2L

Table of Contents

§. Safety Precautions

1. Precautions
2. Information servicing(For flammable materials)

§. Specifications

1. Model Reference
2. Pipe length and the Drop Height
3. Air Velocity and Temperature Distributions
4. Refrigerant Cycle Diagrams
5. Electrical Wiring Diagrams

§. Product Features

1. Display Function
2. Safety Features
3. Basic Features

§. Maintenance

1. First Time Installation Check
2. Refrigerant Recharge
3. Re-Installation

§. Troubleshooting

1. Safety Caution
2. General Troubleshooting
3. Outdoor Unit Point Check Function
4. Complain Record Form
5. Information Inquiry
6. Error Diagnosis and Troubleshooting Without Error Code
7. Quick Maintenance by Error Code
8. Troubleshooting by Error Code
9. Check Procedures

Appendix

- i) Temperature Sensor Resistance Value Table for T1,T2,T3 and T4 (°C – K)
 - ii) Temperature Sensor Resistance Value Table for TP(for some units) (°C – K)
 - iii) Pressure On Service Port
- 

Safety Precautions

Contents

1.	Precautions.....	2
2.	Information servicing(For flammable materials).....	4

1. Precautions

To prevent personal injury, or property or unit damage, adhere to all precautionary measures and instructions outlined in this manual. Before servicing a unit, refer to this service manual and its relevant sections.

Failure to adhere to all precautionary measures listed in this section may result in personal injury, damage to the unit or to property, or in extreme cases, death.

 **WARNING** indicates a potentially hazardous situation which if not avoided could result in serious personal injury, or death.

 **CAUTION** indicates a potentially hazardous situation which if not avoided could result in minor or moderate personal injury, or unit damage.

1.1 In case of Accidents or Emergency

WARNING

- If a gas leak is suspected, immediately turn off the gas and ventilate the area if a gas leak is suspected before turning the unit on.
- If strange sounds or smoke is detected from the unit, turn the breaker off and disconnect the power supply cable.
- If the unit comes into contact with liquid, contact an authorized service center.
- If liquid from the batteries makes contact with skin or clothing, immediately rinse or wash the area well with clean water.
- Do not insert hands or other objects into the air inlet or outlet while the unit is plugged in.
- Do not operate the unit with wet hands.
- Do not use a remote controller that has previously been exposed to battery damage or battery leakage.

CAUTION

- Clean and ventilate the unit at regular intervals when operating it near a stove or near similar devices.
- Do not use the unit during severe weather conditions. If possible, remove the product from the window before such occurrences.

1.2 Pre-Installation and Installation

WARNING

- Use this unit only on a dedicated circuit.
- Damage to the installation area could cause the unit to fall, potentially resulting in personal injury, property damage, or product failure.
- Only qualified personnel should disassemble, install, remove, or repair the unit.
- Only a qualified electrician should perform electrical work. For more information, contact your dealer, seller, or an authorized service center.

CAUTION

- While unpacking be careful of sharp edges around the unit as well as the edges of the fins on the condenser and evaporator.

1.3 Operation and Maintenance

WARNING

- Do not use defective or under-rated circuit breakers.
- Ensure the unit is properly grounded and that a dedicated circuit and breaker are installed.
- Do not modify or extend the power cable. Ensure the power cable is secure and not damaged during operation.
- Do not unplug the power supply plug during operation.
- Do not store or use flammable materials near the unit.
- Do not open the inlet grill of the unit during operation.
- Do not touch the electrostatic filter if the unit is equipped with one.
- Do not block the inlet or outlet of air flow to the unit.
- Do not use harsh detergents, solvents, or similar items to clean the unit. Use a soft cloth for cleaning.
- Do not touch the metal parts of the unit when removing the air filter as they are very sharp.
- Do not step on or place anything on the unit or outdoor units.
- Do not drink water drained from the unit
- Avoid direct skin contact with water drained from the unit.
- Use a firm stool or step ladder according to manufacturer procedures when cleaning or maintaining the unit.

CAUTION

- Do not install or operate the unit for an extended period of time in areas of high humidity or in an environment directly exposing it to sea wind or salt spray.
- Do not install the unit on a defective or damaged installation stand, or in an unsecure location.
- Ensure the unit is installed at a level position
- Do not install the unit where noise or air discharge created by the outdoor unit will negatively impact the environment or nearby residences.
- Do not expose skin directly to the air discharged by the unit for prolonged periods of time.
- Ensure the unit operates in areas water or other liquids.
- Ensure the drain hose is installed correctly to ensure proper water drainage.
- When lifting or transporting the unit, it is recommended that two or more people are used for this task.
- When the unit is not to be used for an extended time, disconnect the power supply or turn off the breaker.

⚠ WARNING For Using Flammable Refrigerant

1. Installation (Space)
 - That the installation of pipe-work shall be kept to a minimum.
 - That pipe-work shall be protected from physical damage.
 - Where refrigerant pipes shall be compliance with national gas regulations.
 - That mechanical connections shall be accessible for maintenance purposes.
 - In cases that require mechanical ventilation, ventilation openings shall be kept clear of obstruction.
 - When disposing of the product is used, be based on national regulations, properly processed.
2. Servicing
 - Any person who is involved with working on or breaking into a refrigerant circuit should hold a current valid certificate from an industry-accredited assessment authority, which authorises their competence to handle refrigerants safely in accordance with an industry recognised assessment specification.
3. Maintenance and repair requiring the assistance of other skilled personnel shall be carried out under the supervision of the person competent in the use of flammable refrigerants.
4. Do not use means to accelerate the defrosting process or to clean, other than those recommended by the manufacturer.
5. The appliance shall be stored in a room without continuously operating ignition sources (for example: open flames, an operating gas appliance or an operating electric heater).
6. Be more careful that foreign matter (oil, water, etc) does not enter the piping. Also, when storing the piping, securely seal the opening by pinching, taping, etc.
7. Do not pierce or burn.
8. Be aware that refrigerants may not contain an odour.
9. All working procedure that affects safety means shall only be carried by competent persons.
10. Appliance shall be stored in a well-ventilated area where the room size corresponds to the room area as specific for operation.
11. The appliance shall be stored so as to prevent mechanical damage from occurring.
12. Joints shall be tested with detection equipment with a capability of 5 g/year of refrigerant or better, with the equipment in standstill and under operation or under a pressure of at least these standstill or operation conditions after installation. Detachable joints shall NOT be used in the indoor side of the unit (brazed, welded joint could be used).
13. When a FLAMMABLE REFRIGERANT is used, the requirements for installation space of appliance and /or ventilation requirements are determined according to
 - the mass charge amount (M) used in the appliance,
 - the installation location,
 - the type of ventilation of the location or of the appliance.
 - piping material, pipe routing, and installation shall include protection from physical damage in operation and service, and be in compliance with national and local codes and standards, such as ASHRAE 15, IAPMO Uniform Mechanical Code, ICC International Mechanical Code, or CSA B52. All field joints shall be accessible for inspection prior to being covered or enclosed.
 - that protection devices, piping, and fittings shall be protected as far as possible against adverse environmental effects, for example, the danger of water collecting and freezing in relief pipes or the accumulation of dirt and debris;
 - that piping in refrigeration systems shall be so designed and installed to minimize the likelihood of hydraulic shock damaging

the system;

- that steel pipes and components shall be protected against corrosion with a rustproof coating before applying any insulation;
- that precautions shall be taken to avoid excessive vibration or pulsation;
- the minimum floor area of the room shall be mentioned in the form of a table or a single figure without reference to a formula;
- after completion of field piping for split systems, the field pipe-work shall be pressure tested with an inert gas and then vacuum tested prior to refrigerant charging, according to the following requirements:

- The minimum test pressure for the low side of the system shall be the low side design pressure and the minimum test pressure for the high side of the system shall be the high side design pressure, unless the high side of the system, cannot be isolated from the low side of the system in which case the entire system shall be pressure tested to the low side design pressure.
- The test pressure after removal of pressure source shall be maintained for at least 1h with no decrease of pressure indicated by the test gauge, with test gauge resolution not exceeding 5% of the test pressure.
- During the evacuation test, after achieving a vacuum level specified in the manual or less, the refrigeration system shall be isolated from the vacuum pump and the pressure shall not rise above 1500 microns within 10 min. The vacuum pressure level shall be specified in the manual, and shall be the lessor of 500 microns or the value required for compliance with national and local codes and standards, which may vary between residential, commercial, and industrial buildings.

-- field-made refrigerant joints indoors shall be tightness tested according to the following requirements: The test method shall have a sensitivity of 5 grams per year of refrigerant or better under a pressure of at least 0,25 times the maximum allowable pressure. No leak shall be detected.

-- correct the minimum room area of the space A_{min} by multiplying by the altitude adjustment factor (AF) factor in the below table based on for building site ground level altitude (Halt) in meters.

Altitude Adjustment Factor

Halt	0	200	400	600	800	1000	1200	1400	1600
AF	1.00	1.00	1.00	1.00	1.02	1.05	1.07	1.10	1.12
Halt	1800	2000	2200	2400	2600	2800	3000	3200	
AF	1.15	1.18	1.21	1.25	1.28	1.32	1.36	1.40	

-- Warning: keep any required ventilation openings clear of obstruction;

-- Any servicing shall be performed only as recommended by the manufacturer

14. Qualification of workers

Any maintenance, service and repair operations must be required qualification of the working personnel. Every working procedure that affects safety means shall only be carried out by competent persons that joined the training and achieved competence should be documented by a certificate. The training of these procedures is carried out by national training organisations or manufacturers that are accredited to teach the relevant national competency standards that may be set in legislation. All training shall follow the ANNEX HH requirements of UL 60335-2-40 4rd Edition.

Examples for such working procedures are:

- breaking into the refrigerating circuit;
- opening of sealed components;
- opening of ventilated enclosures.

2. Information servicing(For flammable materials)

2.1 Checks to the area

- Prior to beginning work on systems containing flammable refrigerants, safety checks are necessary to ensure that the risk of ignition is minimized. For repair to the refrigerating system, the following precautions shall be complied with prior to conducting work on the system.

2.2 Work procedure

- Work shall be undertaken under a controlled procedure so as to minimise the risk of a flammable gas or vapour being present while the work is being performed.

2.3 General work area

- All maintenance staff and others working in the local area shall be instructed on the nature of work being carried out. Work in confined spaces shall be avoided.

2.4 Checking for presence of refrigerant

- The area shall be checked with an appropriate refrigerant detector prior to and during work, to ensure the technician is aware of potentially flammable atmospheres.
- Ensure that the leak detection equipment being used is suitable for use with flammable refrigerants, i.e. no sparking, adequately sealed or intrinsically safe.

2.5 Presence of fire extinguisher

- If any hot work is to be conducted on the refrigeration equipment or any associated parts, appropriate fire extinguishing equipment shall be available to hand. Have a dry powder or CO₂ fire extinguisher adjacent to the charging area.

2.6 No ignition sources

- No person carrying out work in relation to a refrigeration system which involves exposing any pipe work that contains or has contained flammable refrigerant shall use any sources of ignition in such a manner that it may lead to the risk of fire or explosion.
- All possible ignition sources, including cigarette smoking, should be kept sufficiently far away from the site of installation, repairing, removing and disposal, during which flammable refrigerant can possibly be released to the surrounding space.
- Prior to work taking place, the area around the equipment

is to be surveyed to make sure that there are no flammable hazards or ignition risks.

- NO SMOKING signs shall be displayed.

2.7 Ventilated area

- Ensure that the area is in the open or that it is adequately ventilated before breaking into the system or conducting any hot work. A degree of ventilation shall continue during the period that the work is carried out. The ventilation should safely disperse any released refrigerant and preferably expel it externally into the atmosphere.

2.8 Checks to the refrigeration equipment

- Where electrical components are being changed, they shall be fit for the purpose and to the correct specification. At all times the manufacturer's maintenance and service guidelines shall be followed. If in doubt consult the manufacturer's technical department for assistance. The following checks shall be applied to installations using FLAMMABLE REFRIGERANTS:
 - the actual refrigerant charge is in accordance with the room size within which the refrigerant containing parts are installed;
 - the ventilation machinery and outlets are operating adequately and are not obstructed;
 - if an indirect refrigerating circuit is being used, the secondary circuits shall be checked for the presence of refrigerant;
 - marking to the equipment continues to be visible and legible, marking and signs that are illegible shall be corrected;
 - refrigeration pipe or components are installed in a position where they are unlikely to be exposed to any substance which may corrode refrigerant containing components, unless the components are constructed of materials which are inherently resistant to being corroded or are suitably protected against being so corroded.

2.9 Checks to electrical devices

- Repair and maintenance to electrical components shall include initial safety checks and component inspection procedures. If a fault exists that could compromise safety, then no electrical supply shall be connected to the circuit until it is satisfactorily dealt with. If the fault cannot be corrected immediately but it is necessary to continue operation, an adequate temporary solution shall be used. This shall be reported to the owner of the equipment so all parties are advised. **Initial safety checks shall include:**
 - that capacitors are discharged: this shall be done in a safe manner to avoid possibility of sparking;
 - that there no live electrical components and wiring are exposed while charging, recovering or purging the system;
 - that there is continuity of earth bonding.

2.10 Sealed electrical components shall be replaced

- During repairs to sealed components, all electrical supplies shall be disconnected from the equipment being worked upon prior to any removal of sealed covers, etc. If it is absolutely necessary to have an electrical supply to equipment during servicing, then a permanently operating form of leak detection shall be located at the most critical point to warn of a potentially hazardous situation.
- Particular attention shall be paid to the following to ensure that by working on electrical components, the casing is not altered in such a way that the level of protection is affected. This shall include damage to cables, excessive number of connections, terminals not made to original specification, damage to seals, incorrect fitting of glands, etc.
 - Ensure that apparatus is mounted securely.
 - Ensure that seals or sealing materials have not degraded such that they no longer serve the purpose of preventing the ingress of flammable atmospheres. Replacement parts shall be in accordance with the manufacturer's specifications.

2.11 Intrinsically safe components must be replaced

- Do not apply any permanent inductive or capacitance loads to the circuit without ensuring that this will not exceed the permissible voltage and current permitted for the equipment in use. Intrinsically safe components are the only types that can be worked on while live in the presence of a flammable atmosphere. The test apparatus shall be at the correct rating. Replace components only with parts specified by the manufacturer. Other parts may result in the ignition of refrigerant in the atmosphere from a leak.

NOTE: The use of silicon sealant may inhibit the effectiveness of some types of leak detection equipment. Intrinsically safe components do not have to be isolated prior to working on them.

2.12 Cabling

- Check that cabling will not be subject to wear, corrosion, excessive pressure, vibration, sharp edges or any other adverse environmental effects. The check shall also take into account the effects of aging or continual vibration from sources such as compressors or fans.

2.13 Detection of flammable refrigerants

- Under no circumstances shall potential sources of ignition be used in the searching for or detection of refrigerant leaks. A halide torch (or any other detector using a naked flame) shall not be used.
- The following leak detection methods are deemed acceptable for refrigerant systems. Electronic leak detectors may be used to detect refrigerant leaks but, in the case of FLAMMABLE REFRIGERANTS, the sensitivity may not be

adequate, or may need re-calibration. (Detection equipment shall be calibrated in a refrigerant-free area.) Ensure that the detector is not a potential source of ignition and is suitable for the refrigerant used. Leak detection equipment shall be set at a percentage of the LFL of the refrigerant and shall be calibrated to the refrigerant employed, and the appropriate percentage of gas (25 % maximum) is confirmed. Leak detection fluids are also suitable for use with most refrigerants but the use of detergents containing chlorine shall be avoided as the chlorine may react with the refrigerant and corrode the copper pipe-work.

NOTE Examples of leak detection fluids are

- bubble method,
- fluorescent method agents.
 - If a leak is suspected, all naked flames shall be removed/ extinguished.
 - If a leakage of refrigerant is found which requires brazing, all of the refrigerant shall be recovered from the system, or isolated (by means of shut of valves) in a part of the system remote from the leak. See the following instructions of removal of refrigerant.

2.14 Removal and evacuation

- When breaking into the refrigerant circuit to make repairs or for any other purpose, conventional procedures shall be used. However, it is important that best practice is followed since flammability is a consideration.
- The following procedure shall be adhered to:
 - safely remove refrigerant following local and national regulations;
 - evacuate;
 - purge the circuit with inert gas(optional for A2L);
 - evacuate(optional for A2L);
 - continuously flush or purge with inert gas when using flame to open circuit; and open the circuit;
- The refrigerant charge shall be recovered into the correct recovery cylinders if venting is not allowed by local and national codes. For appliances containing flammable refrigerants, the system shall be purged with oxygen-free nitrogen to render the appliance safe for flammable refrigerants. This process might need to be repeated several times. Compressed air or oxygen shall not be used for purging refrigerant systems.
- For appliances containing flammable refrigerants, refrigerants purging shall be achieved by breaking the vacuum in the system with oxygen-free nitrogen and continuing to fill until the working pressure is achieved, then venting to atmosphere, and finally pulling down to a vacuum (optional for A2L). This process shall be repeated until no refrigerant is within the system (optional for A2L). When the final oxygen-free nitrogen charge is used, the system shall be vented down to atmospheric pressure to enable work to take place.
- The outlet for the vacuum pump shall not be close to any potential ignition sources, and ventilation shall be available.

2.15 Charging procedures

- In addition to conventional charging procedures, the following requirements shall be followed:
 - Works shall be undertaken with appropriate tools only (In case of uncertainty, please consult the manufacturer of the tools for use with flammable refrigerants)
 - Ensure that contamination of different refrigerants does not occur when using charging equipment. Hoses or lines shall be as short as possible to minimize the amount of refrigerant contained in them.
 - Cylinders shall be kept upright.
 - Ensure that the refrigeration system is earthed prior to charging the system with refrigerant.
 - Label the system when charging is complete (if not already). Extreme care shall be taken not to overfill the refrigeration system.
 - Prior to recharging the system it shall be pressure tested with OFN. The system shall be leak tested on completion of charging but prior to commissioning. A follow up leak test shall be carried out prior to leaving the site.

2.16 Decommissioning

Before carrying out this procedure, it is essential that the technician is completely familiar with the equipment and all its detail. It is recommended good practice that all refrigerants are recovered safely. Prior to the task being carried out, an oil and refrigerant sample shall be taken in case analysis is required prior to re-use of recovered refrigerant. It is essential that electrical power is available before the task is commenced.

- Become familiar with the equipment and its operation.
- Isolate system electrically.
- Before attempting the procedure ensure that:
 - mechanical handling equipment is available, if required, for handling refrigerant cylinders;
 - all personal protective equipment is available and being used correctly;
 - the recovery process is supervised at all times by a competent person;
 - recovery equipment and cylinders conform to the appropriate standards.
- Pump down refrigerant system, if possible.
- If a vacuum is not possible, make a manifold so that refrigerant can be removed from various parts of the system.
- Make sure that cylinder is situated on the scales before recovery takes place.
- Start the recovery machine and operate in accordance with manufacturer's instructions.
- Do not overfill cylinders. (No more than 80 % volume liquid charge).
- Do not exceed the maximum working pressure of the cylinder, even temporarily.
- When the cylinders have been filled correctly and the process

completed, make sure that the cylinders and the equipment are removed from site promptly and all isolation valves on the equipment are closed off.

- Recovered refrigerant shall not be charged into another refrigeration system unless it has been cleaned and checked.

2.17 Labelling

- Equipment shall be labelled stating that it has been de-commissioned and emptied of refrigerant. The label shall be dated and signed. For appliances containing FLAMMABLE REFRIGERANTS, ensure that there are labels on the equipment stating the equipment contains FLAMMABLE REFRIGERANT.

2.18 Recovery

- When removing refrigerant from a system, either for servicing or decommissioning,
- it is recommended good practice that all refrigerants are removed safely.
- When transferring refrigerant into cylinders, ensure that only appropriate refrigerant recovery cylinders are employed. Ensure that the correct number of cylinders for holding the total system charge is available. All cylinders to be used are designated for the recovered refrigerant and labelled for that refrigerant (i. e. special cylinders for the recovery of refrigerant). Cylinders shall be complete with pressure-relief valve and associated shut-of valves in good working order. Empty recovery cylinders are evacuated and, if possible, cooled before recovery occurs.
- The recovery equipment shall be in good working order with a set of instructions concerning the equipment that is at hand and shall be suitable for the recovery of the flammable refrigerant. If in doubt the manufacturer should be consulted. In addition, a set of calibrated weighing scales shall be available and in good working order. Hoses shall be complete with leak-free disconnect couplings and in good condition.
- The recovered refrigerant shall be processed according to local legislation in the correct recovery cylinder, and the relevant waste transfer note arranged. Do not mix refrigerants in recovery units and especially not in cylinders.
- If compressors or compressor oils are to be removed, ensure that they have been evacuated to an acceptable level to make certain that flammable refrigerant does not remain within the lubricant. The compressor body shall not be heated by an open flame or other ignition sources to accelerate this process. When oil is drained from a system, it shall be carried out safely.

2.19 Transportation, marking and storage for units

1. Transport of equipment containing flammable refrigerants
Compliance with the transport regulations
2. Marking of equipment using signs

Compliance with local regulations

3. Disposal of equipment using flammable refrigerants

Compliance with national regulations

4. Storage of equipment/appliances

The storage of equipment should be in accordance with the manufacturer's instructions.

5. Storage of packed (unsold) equipment

Storage package protection should be constructed such that mechanical damage to the equipment inside the package will not cause a leak of the refrigerant charge. The maximum number of pieces of equipment permitted to be stored together will be determined by local regulations.

Specifications

Contents

1. Model Reference.....	2
2. Pipe Length and Drop Height	3
3. Air Velocity and Temperature Distributions	4
4. Refrigerant Cycle Diagrams	16
5. Electrical Wiring Diagrams	18

1. Model Reference

Refer to the following table to determine the specific indoor and outdoor unit model.

Indoor Unit Model	Outdoor Unit Model	Capacity (Btu/h)	Power Supply
B-ZHP06SA-1	A-ZHP06SA-1	6k Hyper Heat Series	208/230V~, 60Hz, 1Phase
B-ZHP09SA-1	A-ZHP09SA-1	9k Hyper Heat Series	
B-ZHP12SA-1	A-ZHP12SA-1	12k Hyper Heat Series	
B-ZHP18SA-1	A-ZHP18SA-1	18k Hyper Heat Series	
B-ZHP24SA-1	A-ZHP24SA-1	24k Hyper Heat Series	
B-ZHP33SA-1	A-ZHP33SA-1	33k Hyper Heat Series	

2. Pipe Length and Drop Height

The length and elevation of connection pipe are shown in the table below. If the pipe length exceeds max pipe length, additional refrigerant should be charged to ensure nominal cooling/heating capacity.

Capacity(Btu/h)	Standard Length	Max Pipe Length	Max Elevation	Additional Refrigerant
≤15k	7.5m (24.6ft)	25m (82.0ft)	15m (49.2ft)	15g/m (0.16oz/ft)
18k		30m (98.4ft)	20m (65.6ft)	
18k High Tier Series/ 24k/30k/33k		50m (164ft)	25m (82ft)	30g/m (0.32oz/ft)
36k		65m (213ft)	30m (98.4ft)	

If oil flows back into the outdoor unit's compressor, this might cause liquid compression or deterioration of oil return. Oil traps in the rising gas pipe can prevent this.

-An oil trap should be installed every 6m(20ft) of vertical suction line riser (<36000Btu/h unit).

-An oil trap should be installed every 10m(32.8ft) of vertical suction line riser (≥36000Btu/h unit).

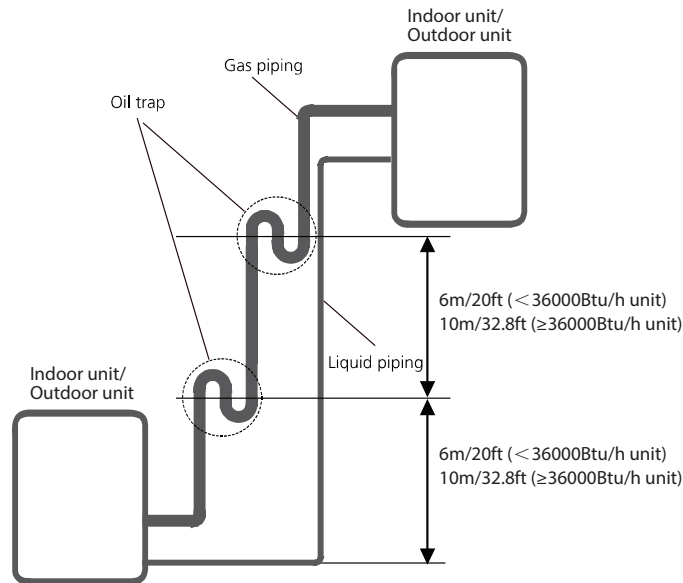

6k-Cooling(ID: 27°C/80.6°F, OD: 35°C/95°F)

Discharge Angle 15°

Airflow velocity distributions

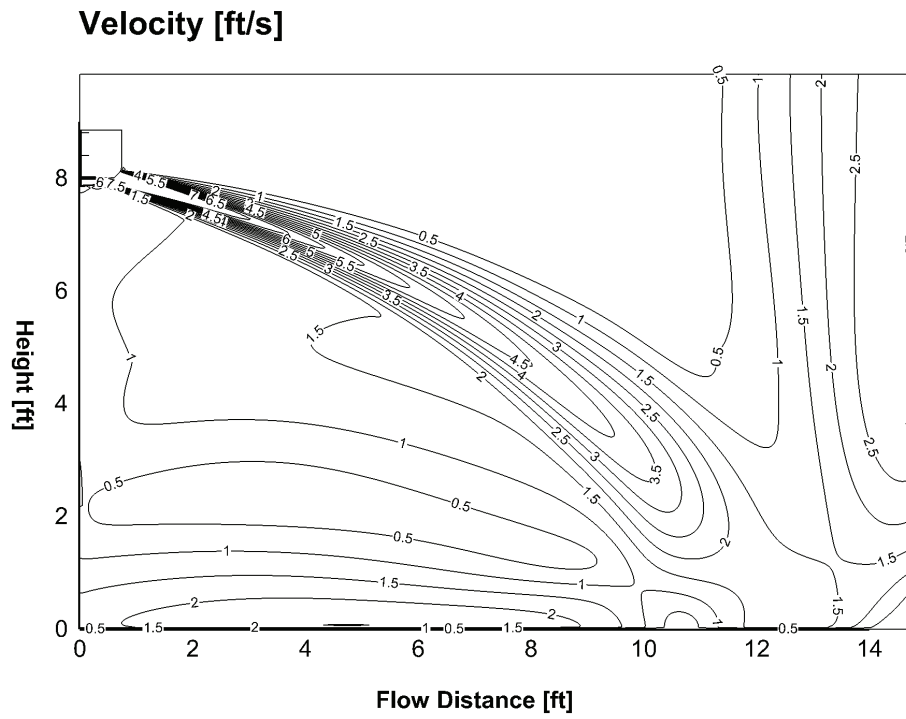

Temperature distributions

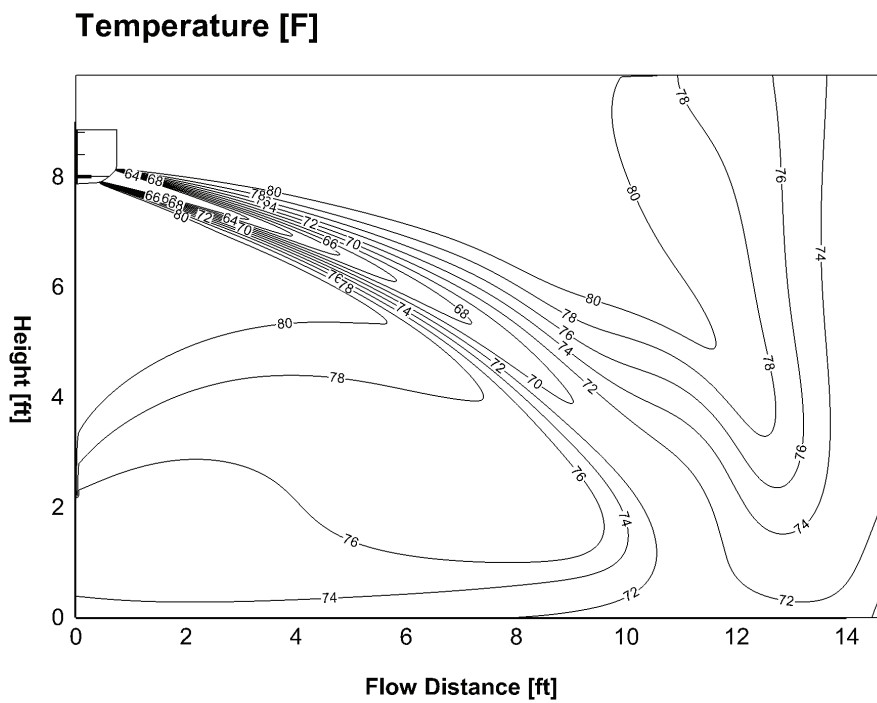

6k-Heating(ID: 20°C/68°F, OD: 7°C/44.6°F)

Discharge Angle 65°

Airflow velocity distributions

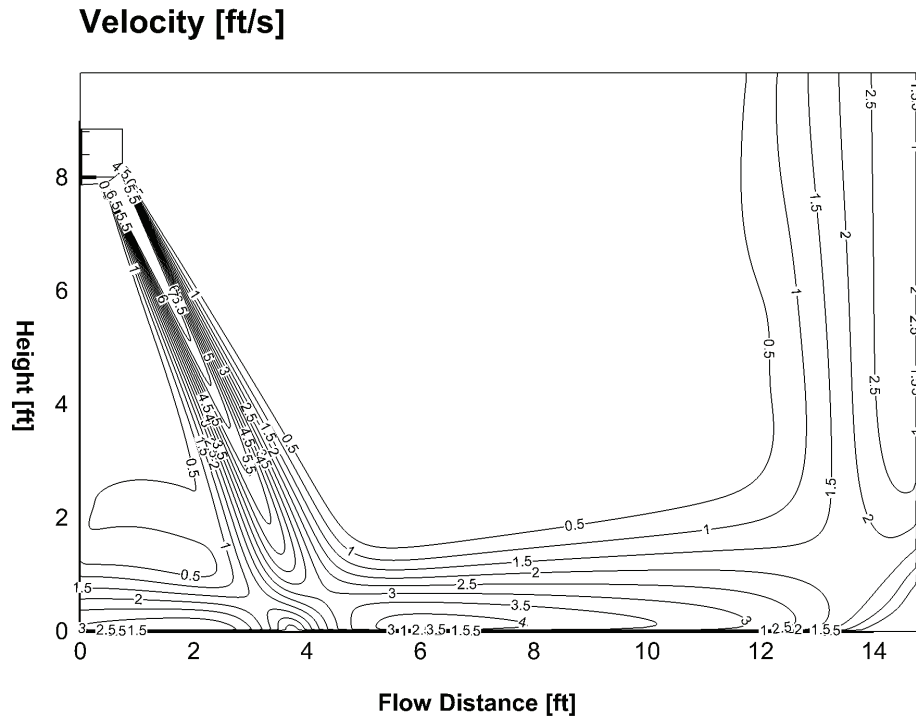

Temperature distributions

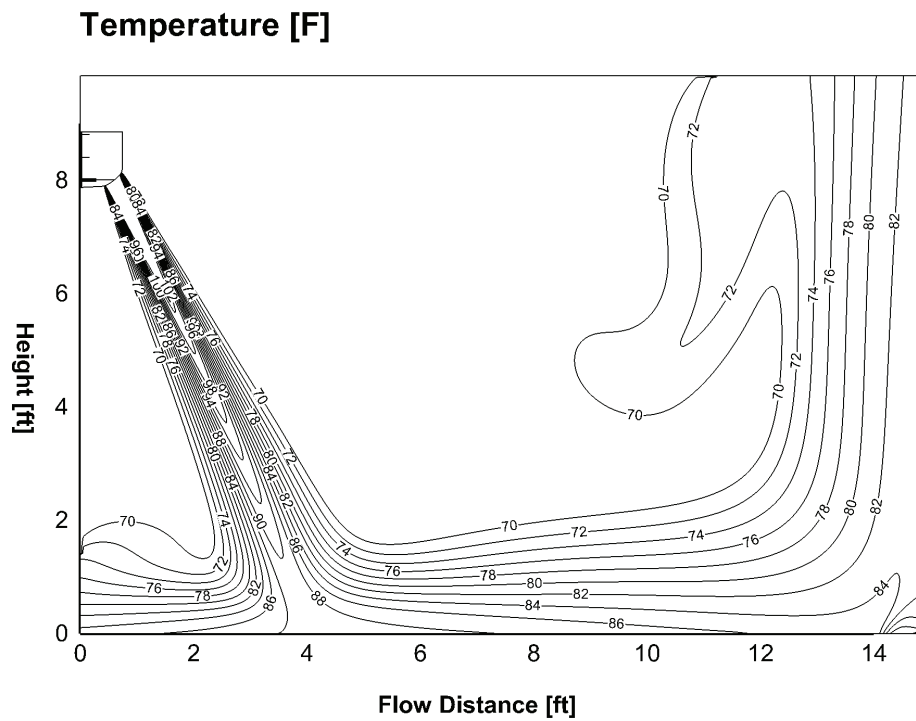

9k-Cooling(ID: 27°C/80.6°F, OD: 35°C/95°F)

Discharge Angle 15°

Airflow velocity distributions

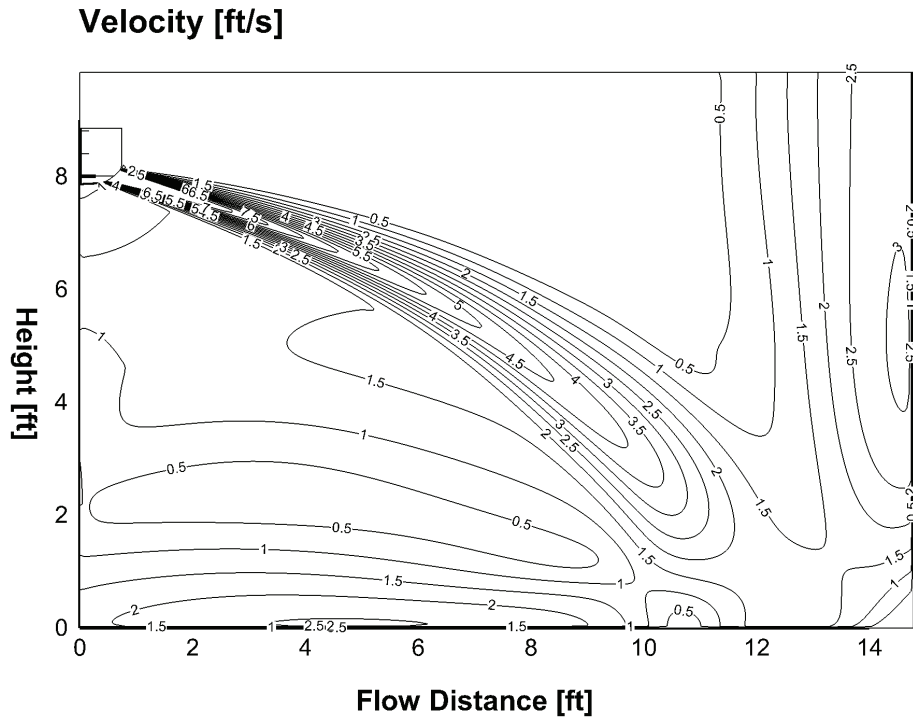

Temperature distributions

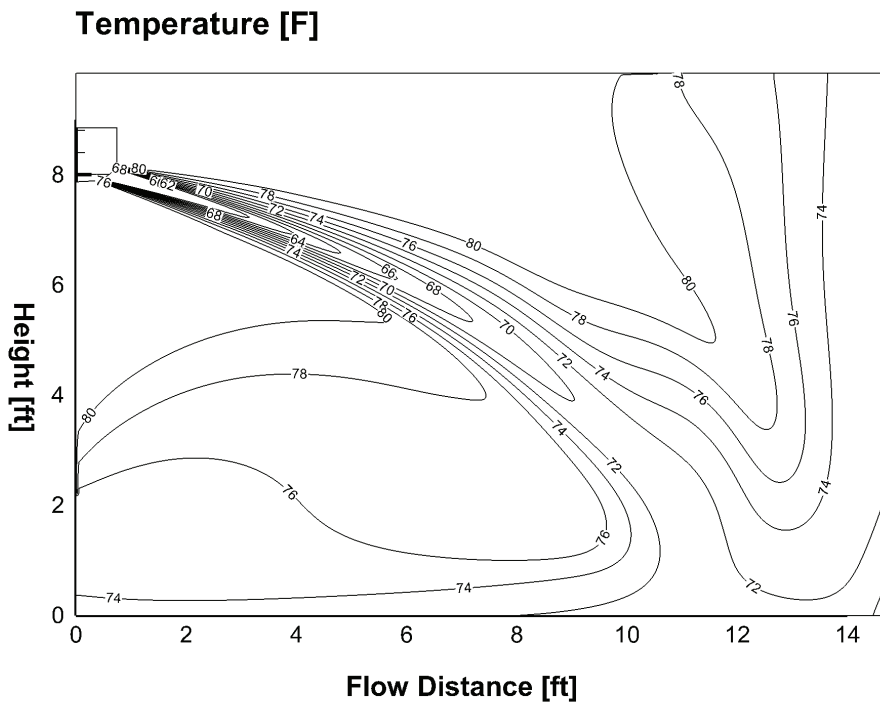

9k-Heating(ID: 20°C/68°F, OD: 7°C/44.6°F)

Discharge Angle 65°

Airflow velocity distributions

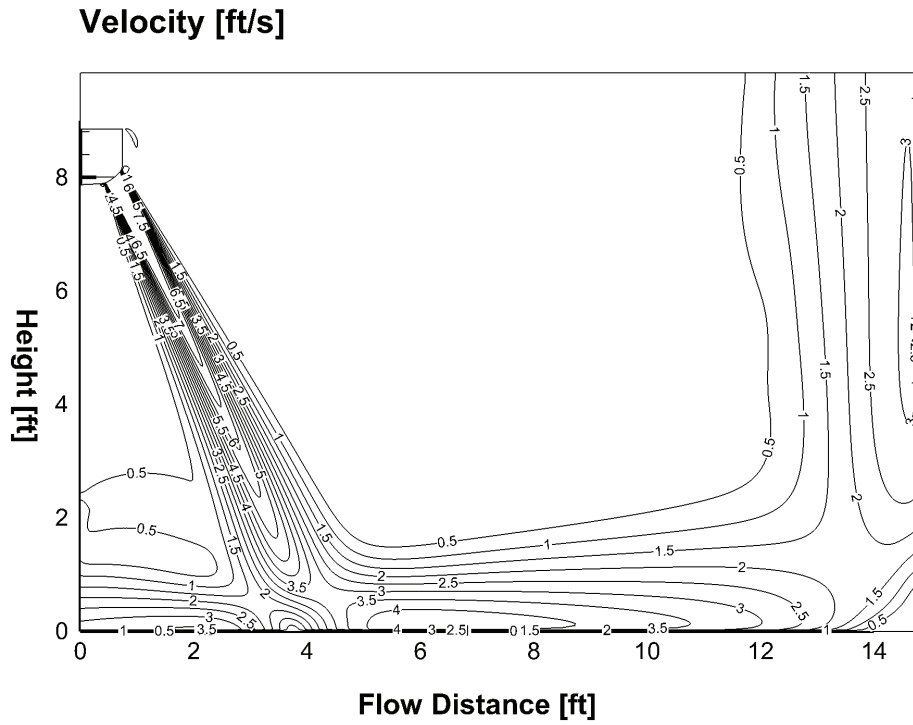

Temperature distributions

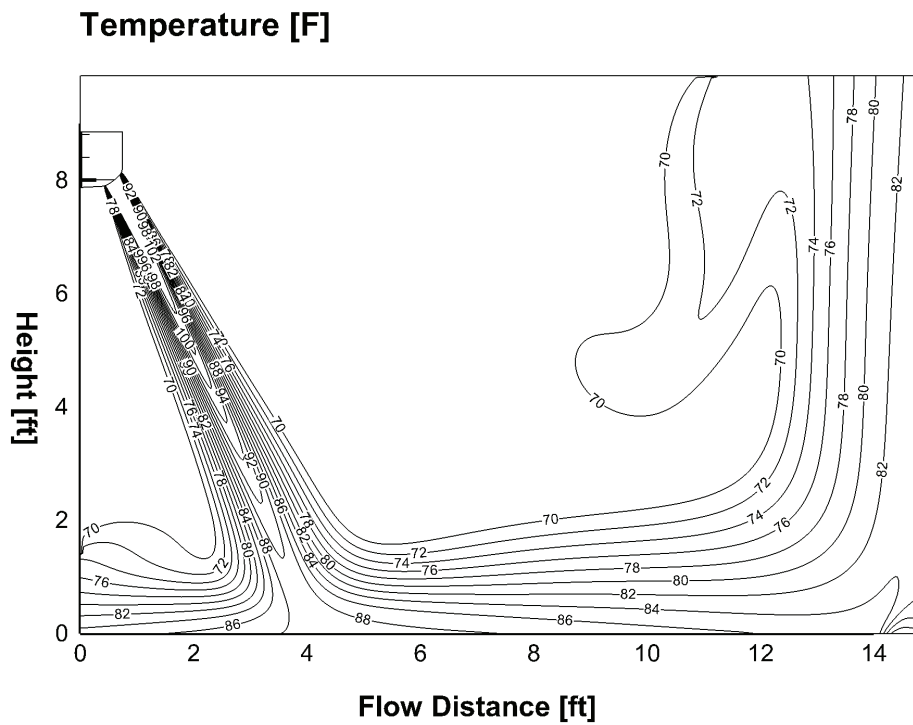

12k/15k-Cooling(ID: 27°C/80.6°F, OD: 35°C/95°F)

Discharge Angle 15°

Airflow velocity distributions

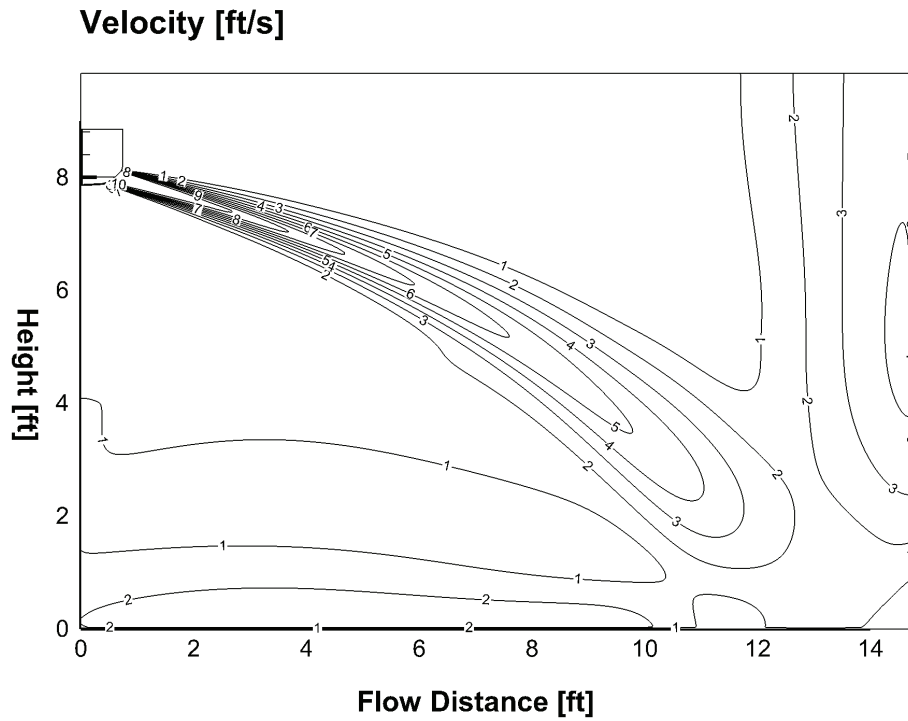

Temperature distributions

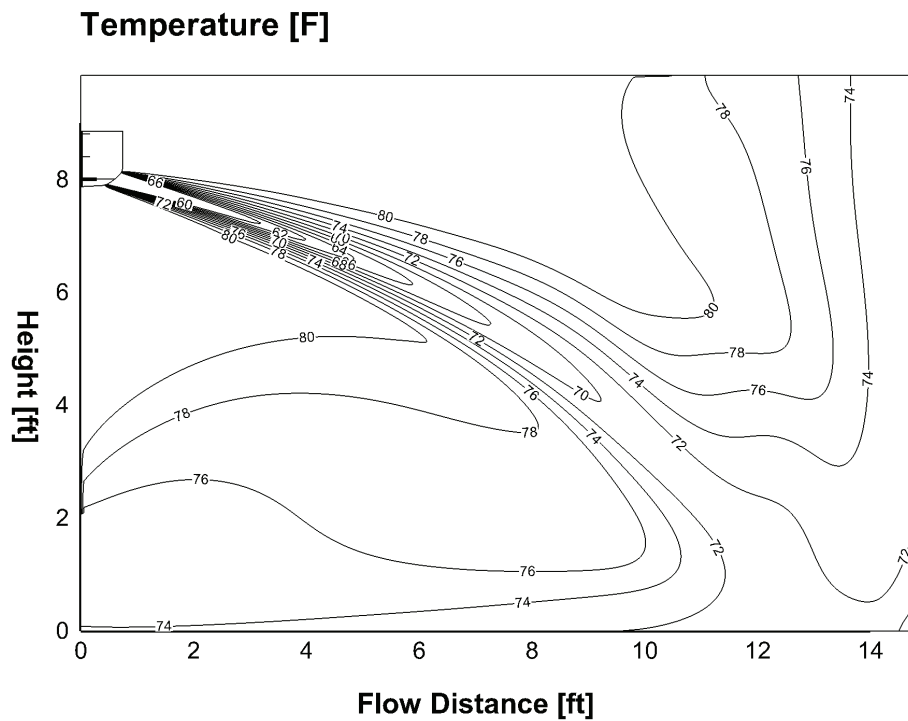

12k/15k-Heating(ID: 20°C/68°F, OD: 7°C/44.6°F)

Discharge Angle 65°

Airflow velocity distributions

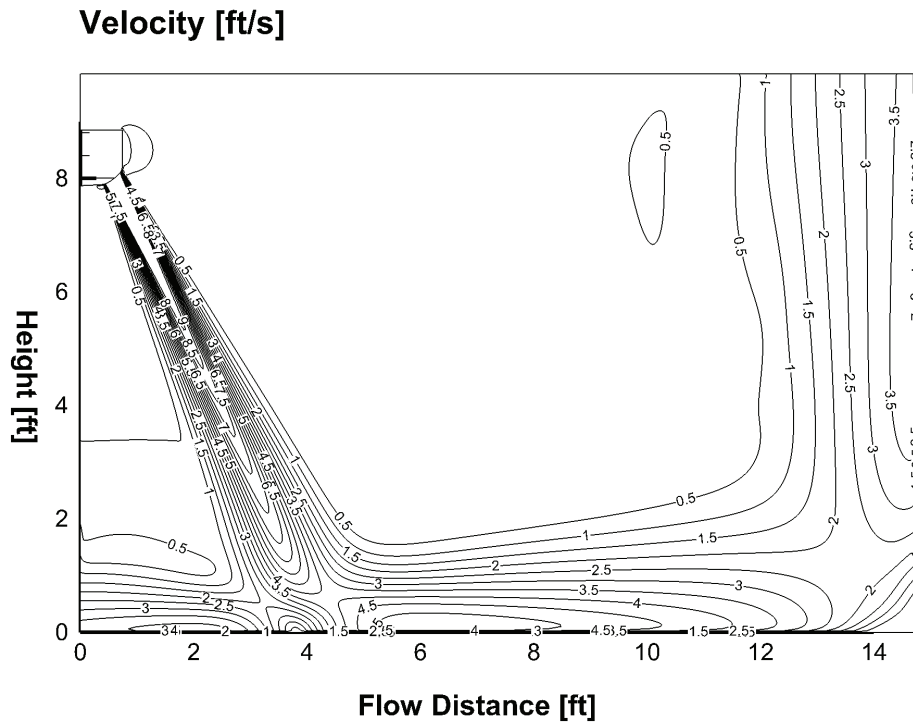

Temperature distributions

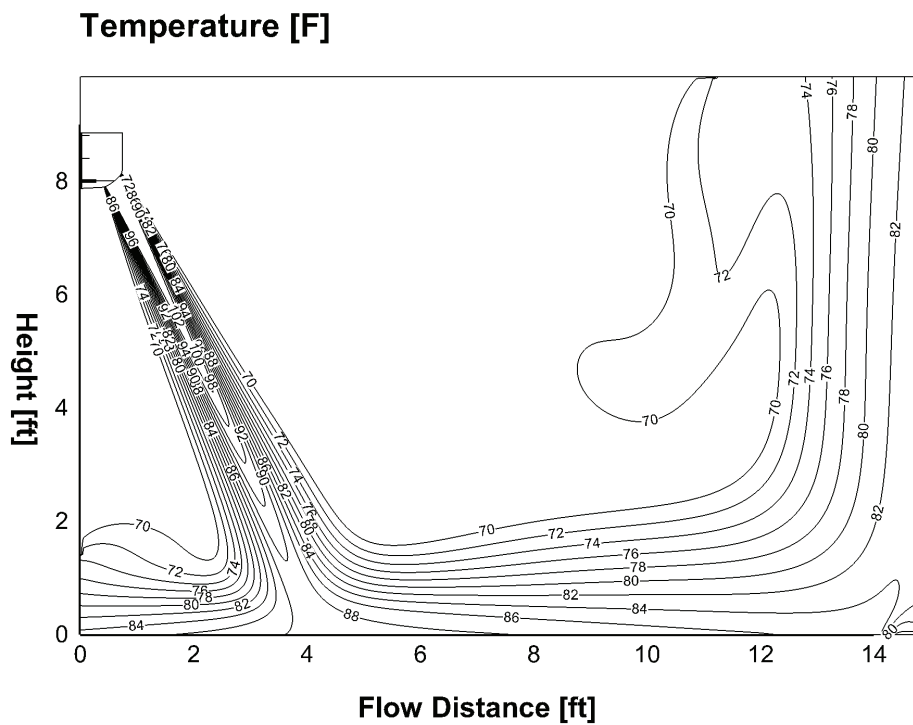

18k-Cooling(ID: 27°C/80.6°F, OD: 35°C/95°F)

Discharge Angle 20°

Airflow velocity distributions

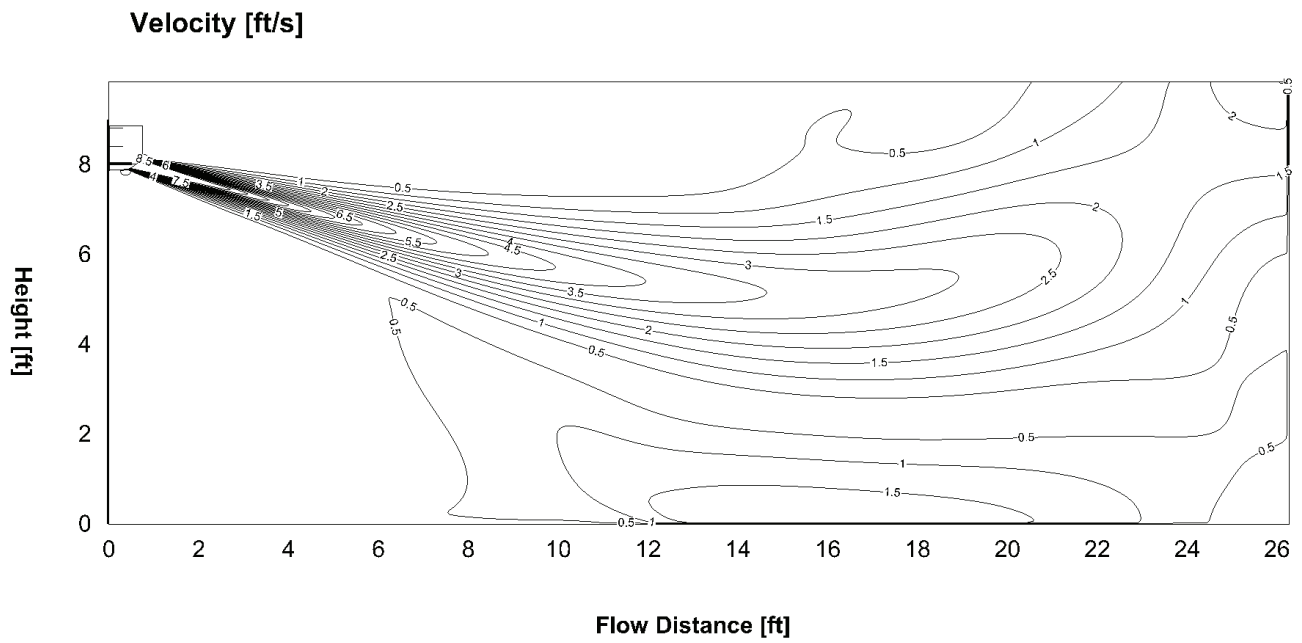

Temperature distributions

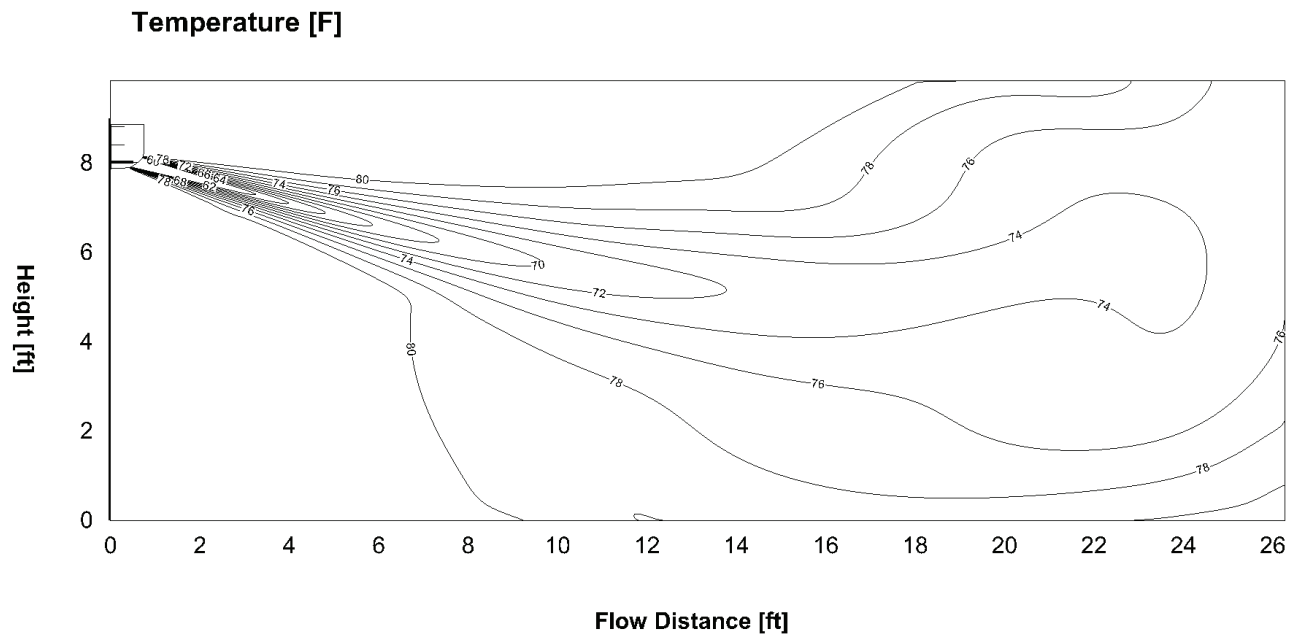

18k-Heating(ID: 20°C/68°F, OD: 7°C/44.6°F)

Discharge Angle 50°

Airflow velocity distributions

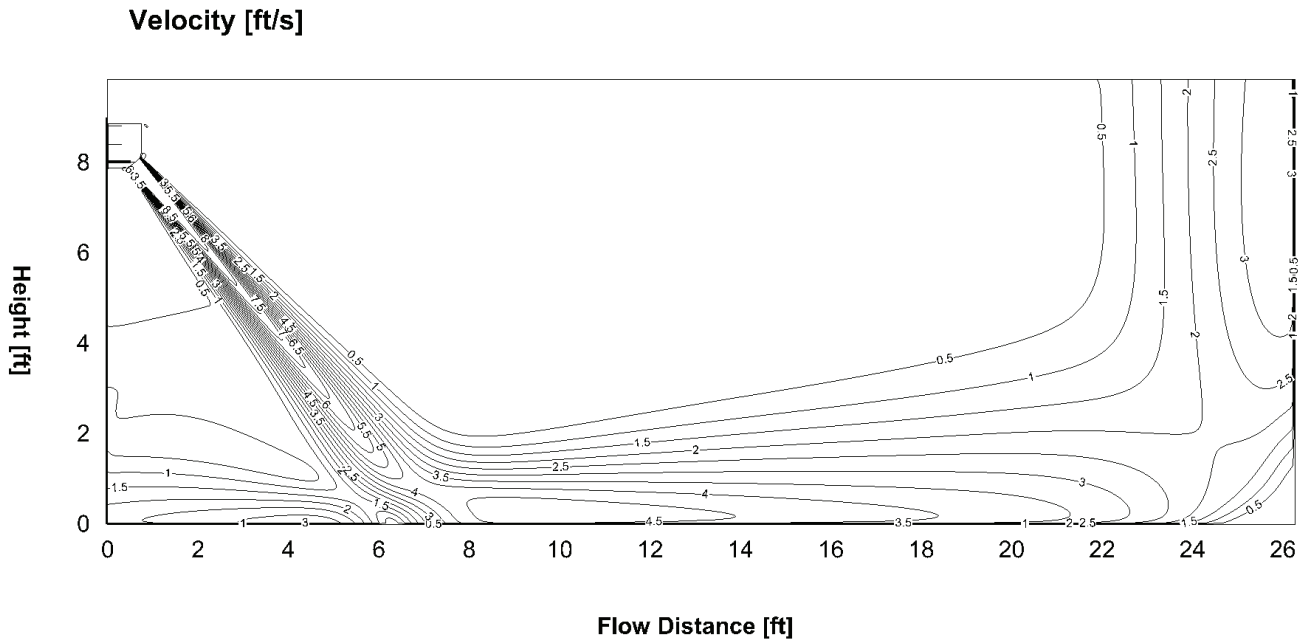

Temperature distributions

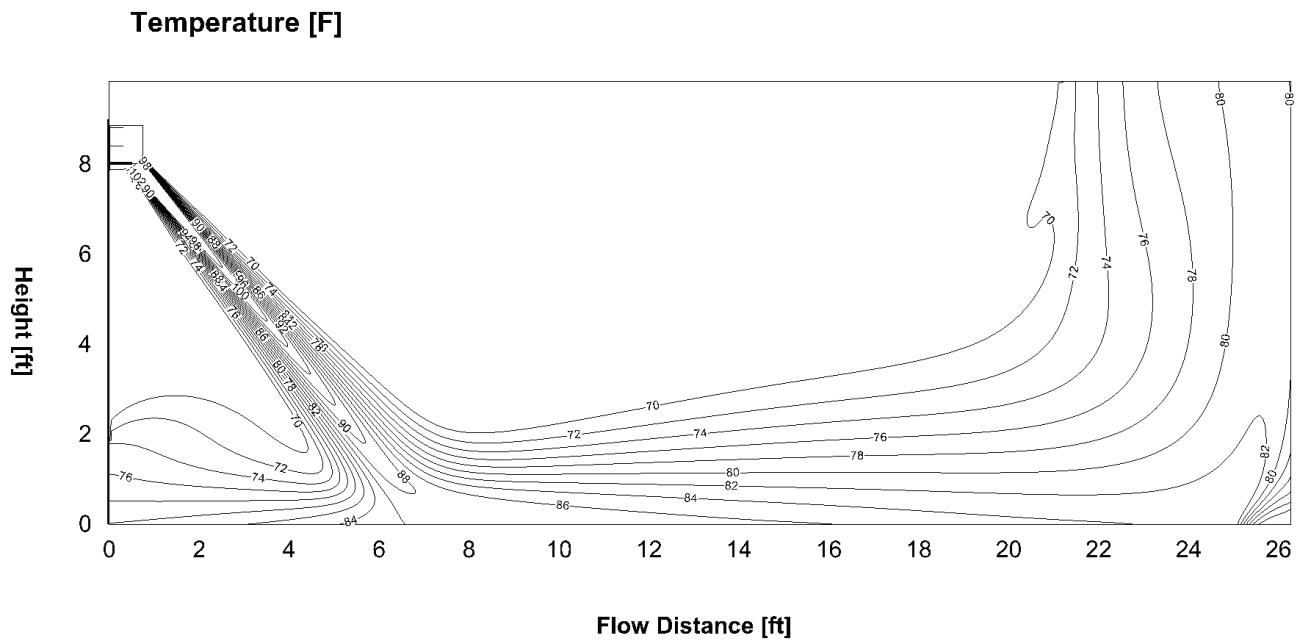

24k-Cooling(ID: 27°C/80.6°F, OD: 35°C/95°F)

Discharge Angle 20°

Airflow velocity distributions

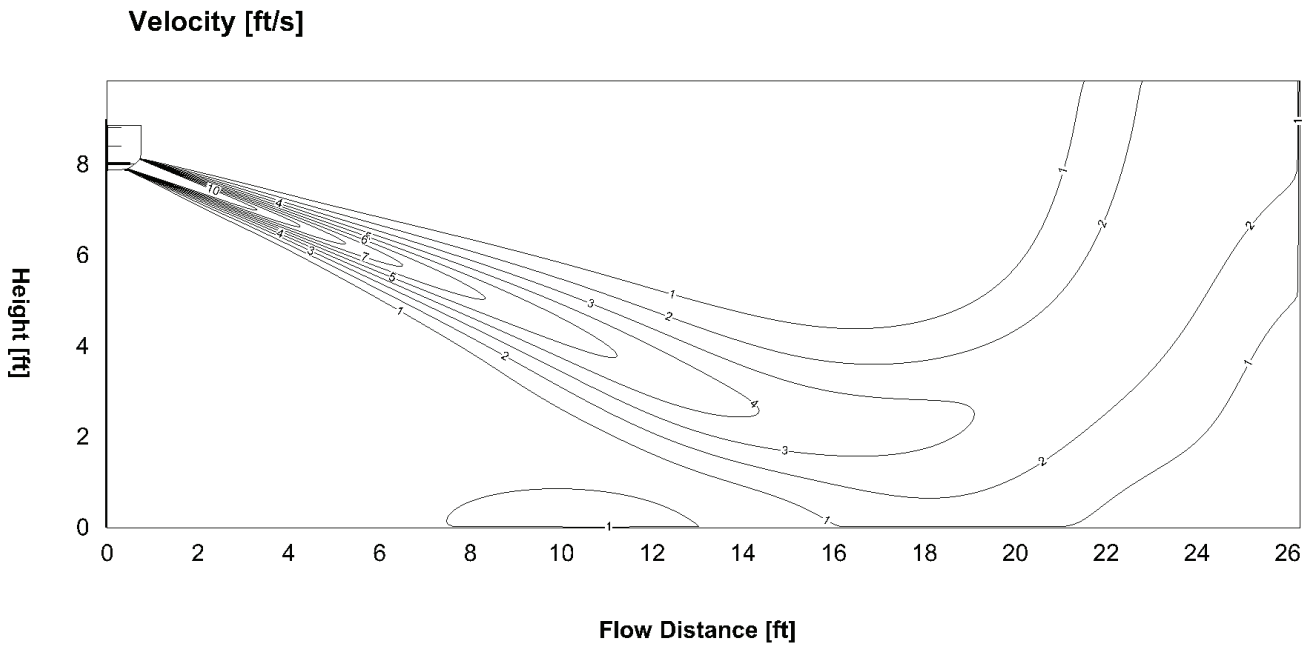

Temperature distributions

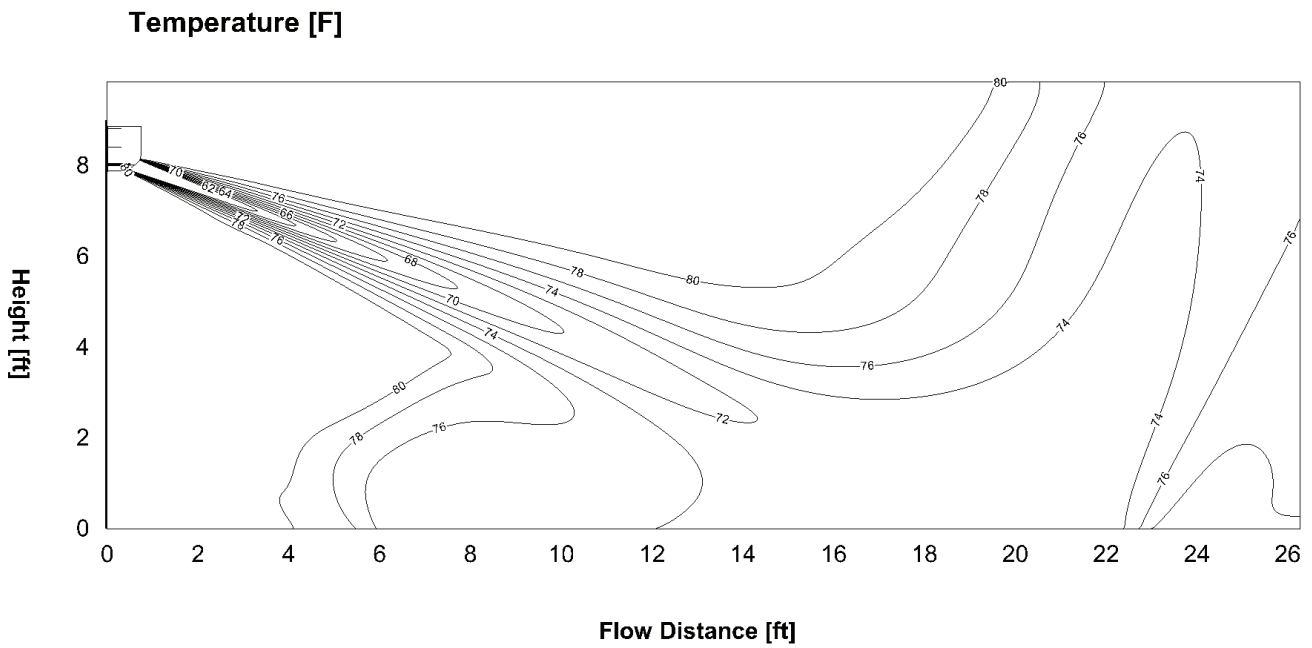

Service Manual - ZHPxxSA

24k-Heating(ID: 20°C/68°F, OD: 7°C/44.6°F)

Discharge Angle 55°

Airflow velocity distributions

Velocity [ft/s]

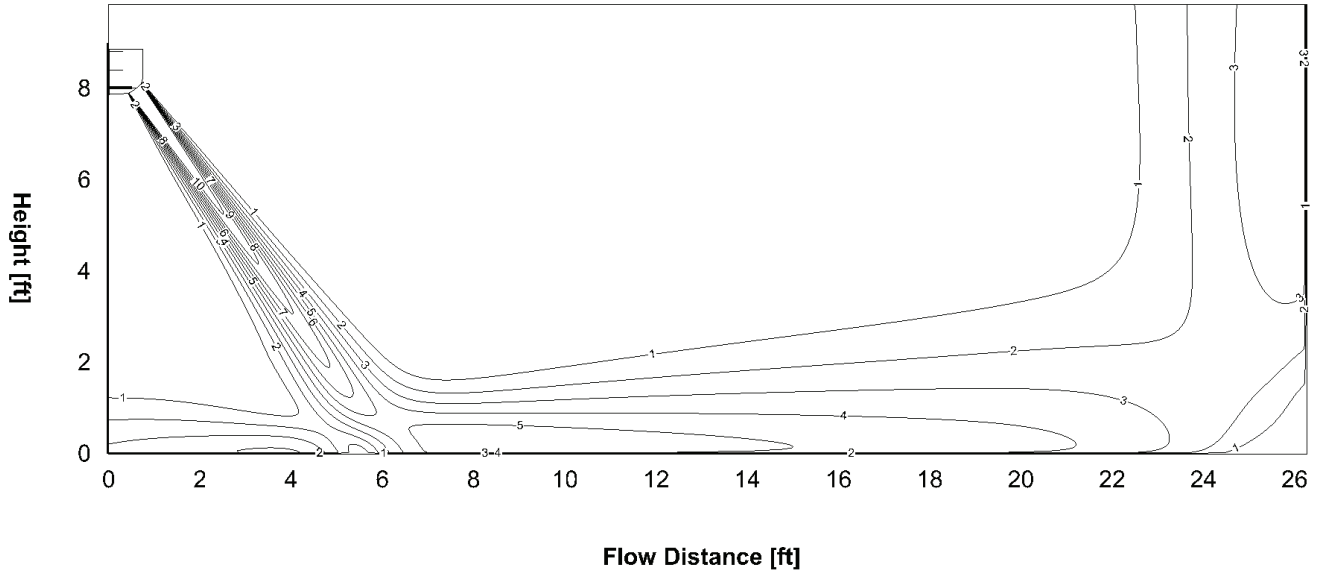

Temperature distributions

Temperature [F]

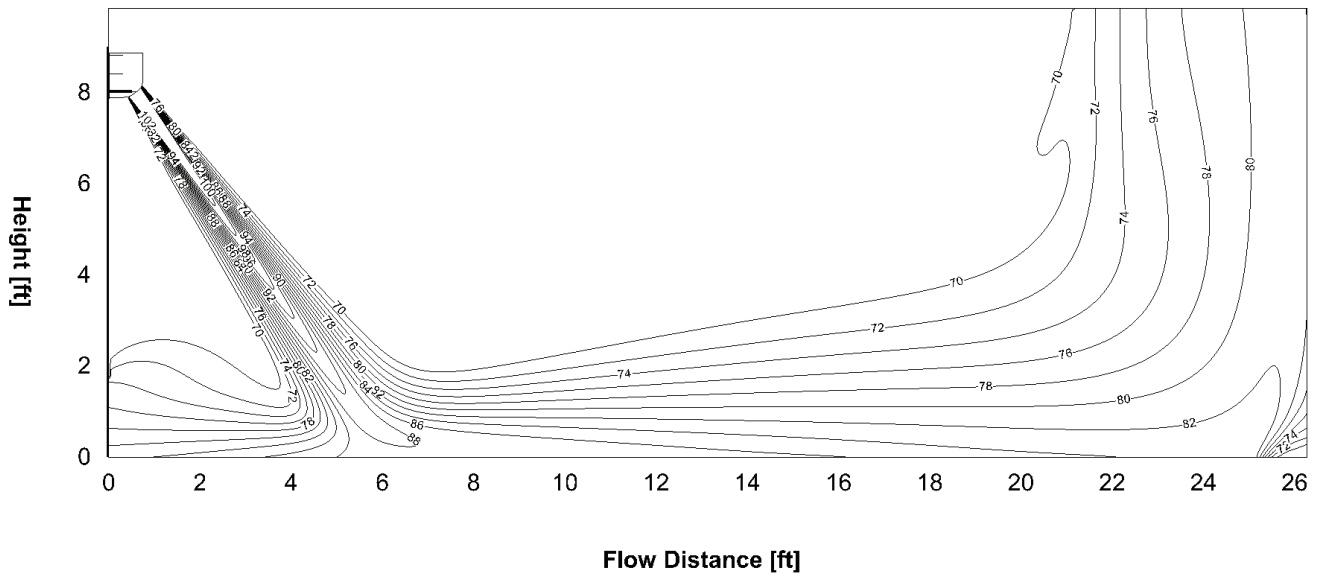

33k-Cooling(ID: 27°C/80.6°F, OD: 35°C/95°F)

Discharge Angle 20°

Airflow velocity distributions

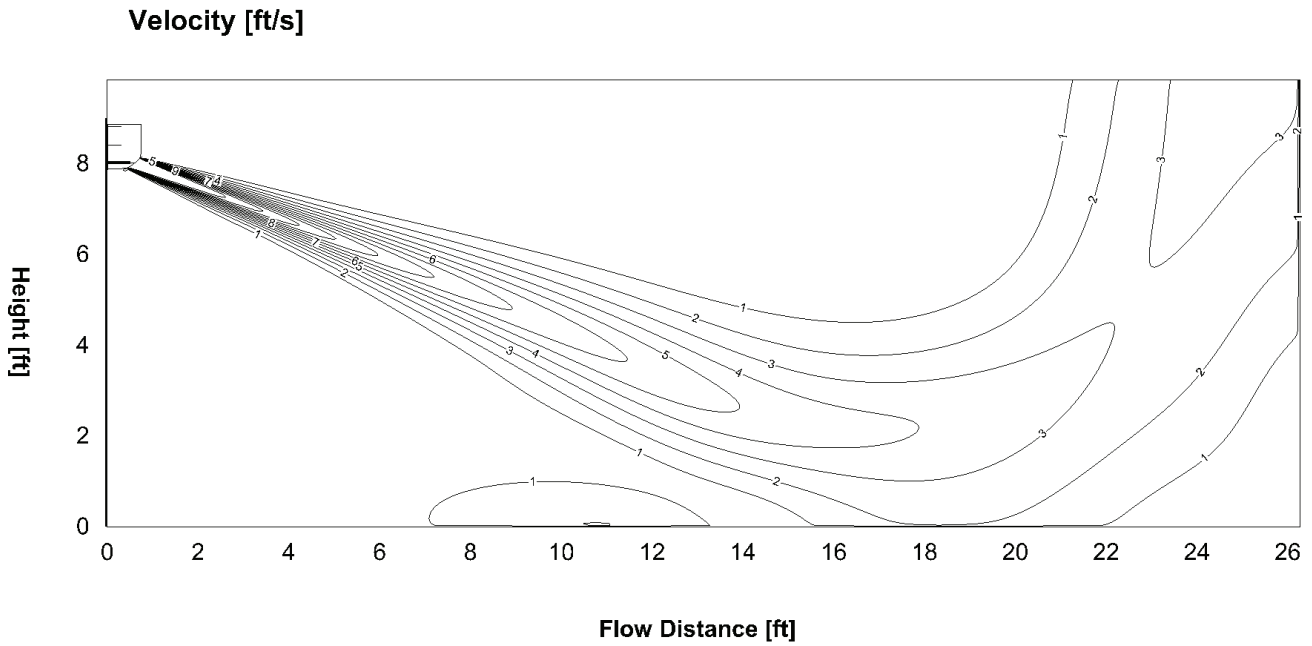

Temperature distributions

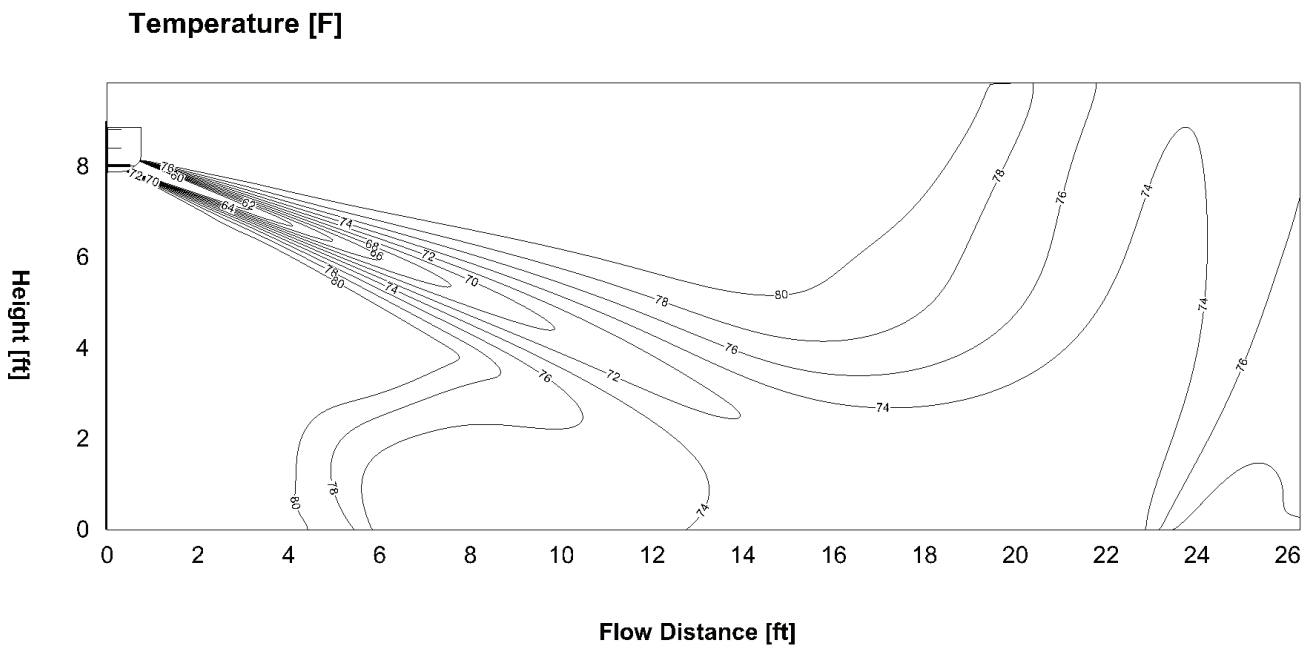

4. Refrigerant Cycle Diagrams

A-ZHP06SA-1, A-ZHP09SA-1, A-ZHP12SA-1

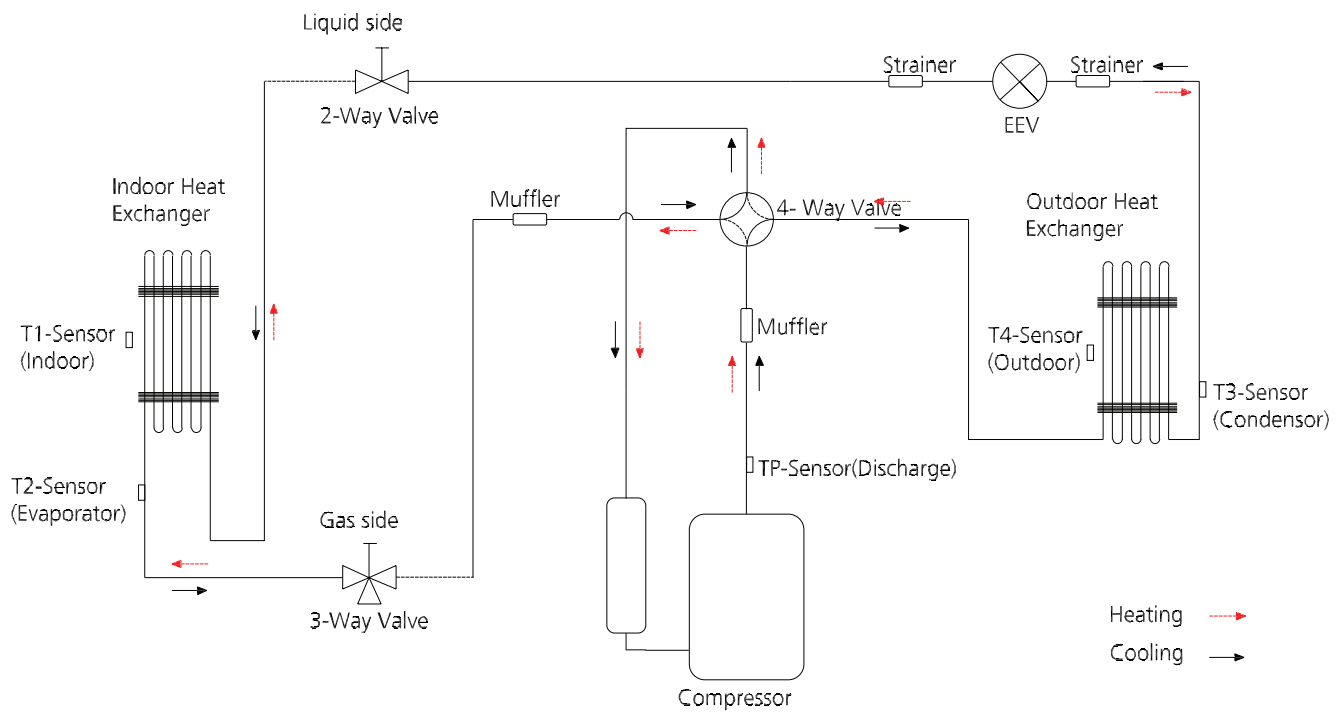

A-ZHP18SA-1 & A-ZHP24SA-1

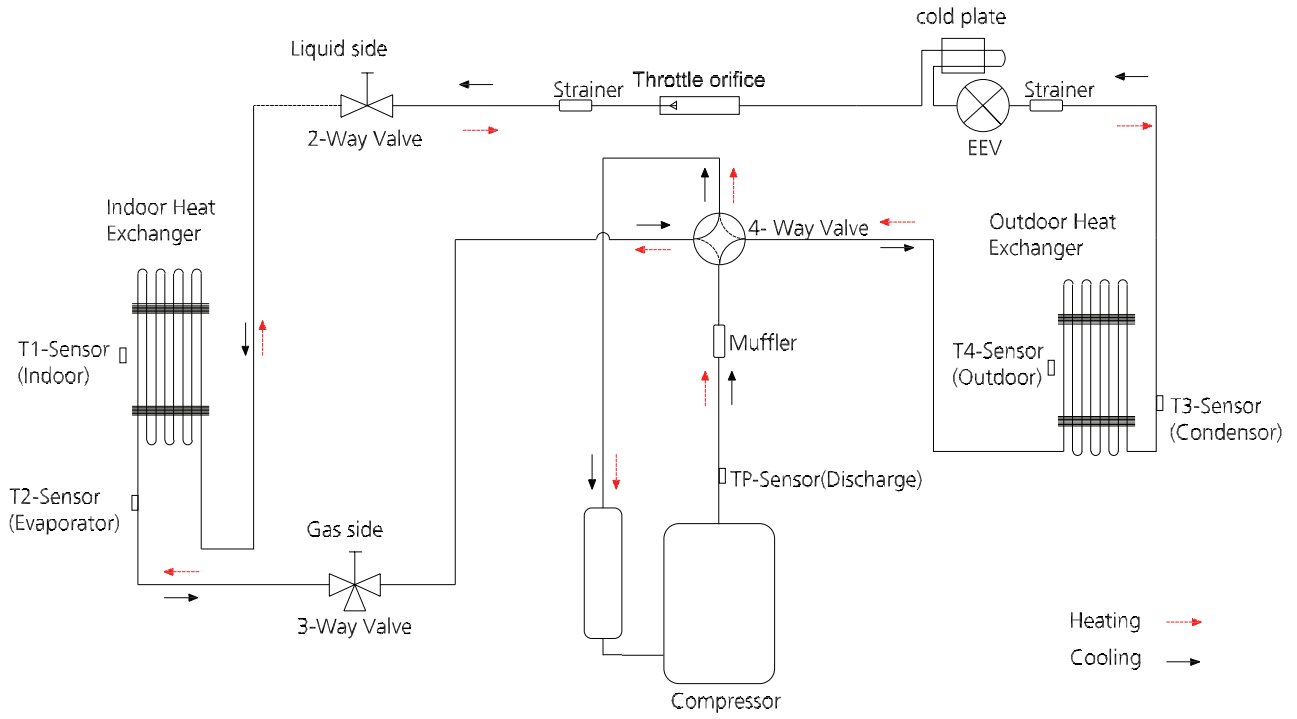

5. Electrical Wiring Diagrams

Indoor unit wiring diagram

Indoor Unit	
IDU Model	IDU Wiring Diagram
B-ZHP06SA-1	16022000040252
B-ZHP09SA-1	
B-ZHP12SA-1	
B-ZHP18SA-1	
B-ZHP24SA-1	

Outdoor unit wiring diagram and printed circuit board diagram

Outdoor Unit		
ODU Model	ODU Wiring Diagram	ODU Printed Circuit Board
A-ZHP06SA-1	16022000041381	17122000057814
A-ZHP09SA-1		
A-ZHP12SA-1		
A-ZHP18SA-1	16022000040331	17122300007152
A-ZHP24SA-1		

Indoor unit wiring diagram: 16022000040252

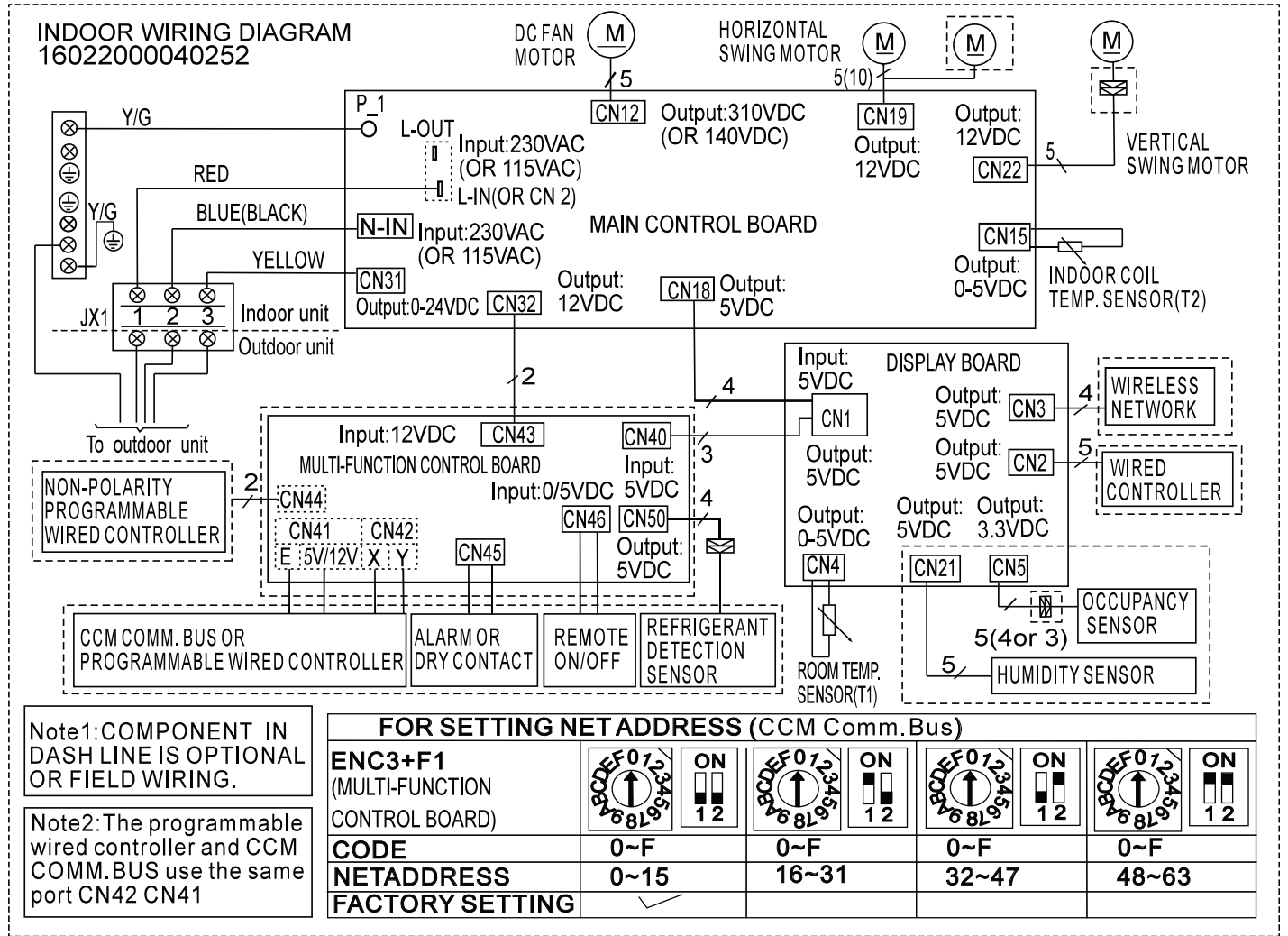

Note1: COMPONENT IN DASH LINE IS OPTIONAL OR FIELD WIRING.

Note2: The programmable wired controller and CCM COMM. BUS use the same port CN42 CN41

FOR SETTING NET ADDRESS (CCM Comm. Bus)				
ENC3+F1 (MULTI-FUNCTION CONTROL BOARD)				
CODE	0~F	0~F	0~F	0~F
NETADDRESS	0~15	16~31	32~47	48~63
FACTORY SETTING	✓			

Outdoor unit wiring diagram: 16022000041381

WIRING DIAGRAM

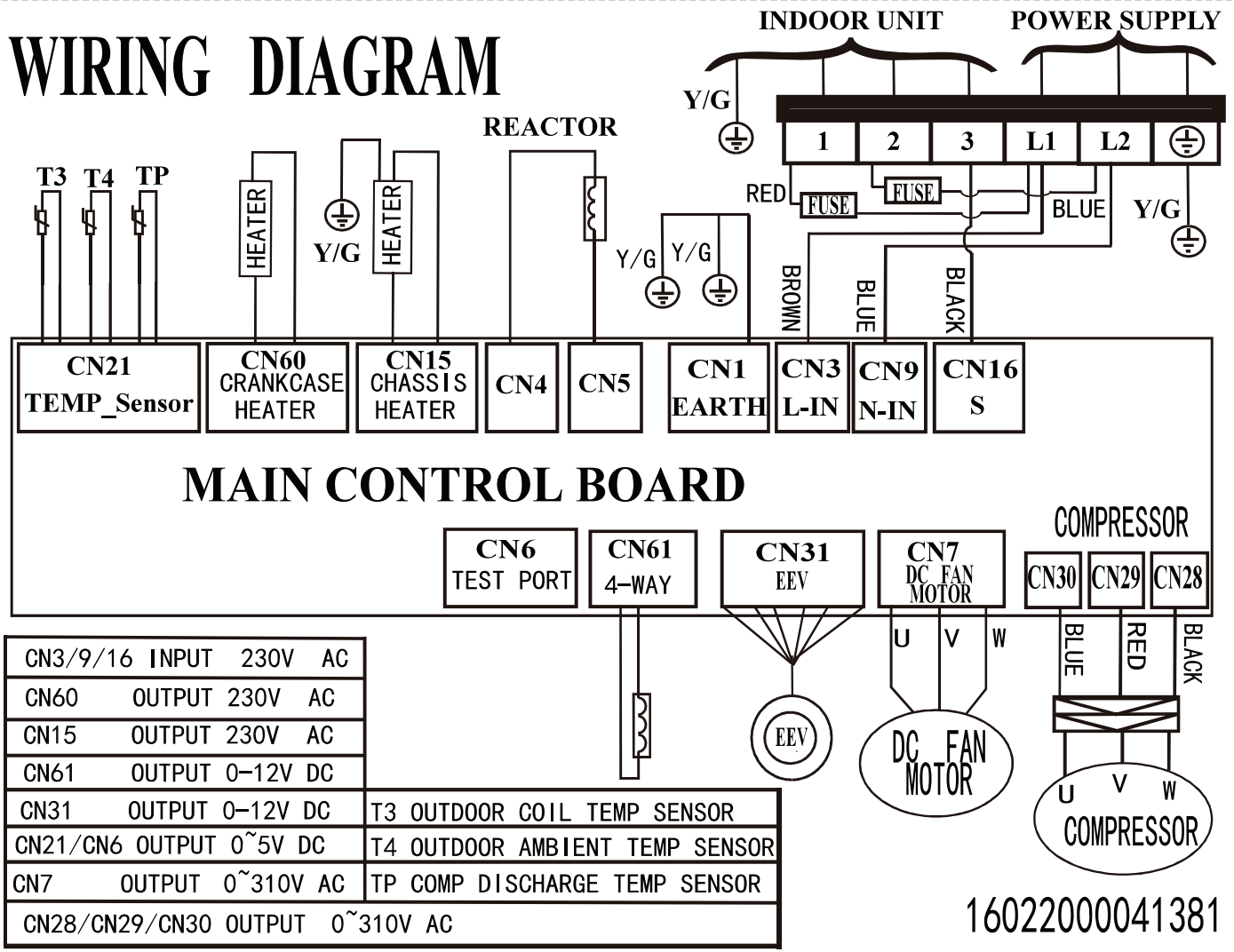

16022000041381

Outdoor unit wiring diagram: 16022000040331

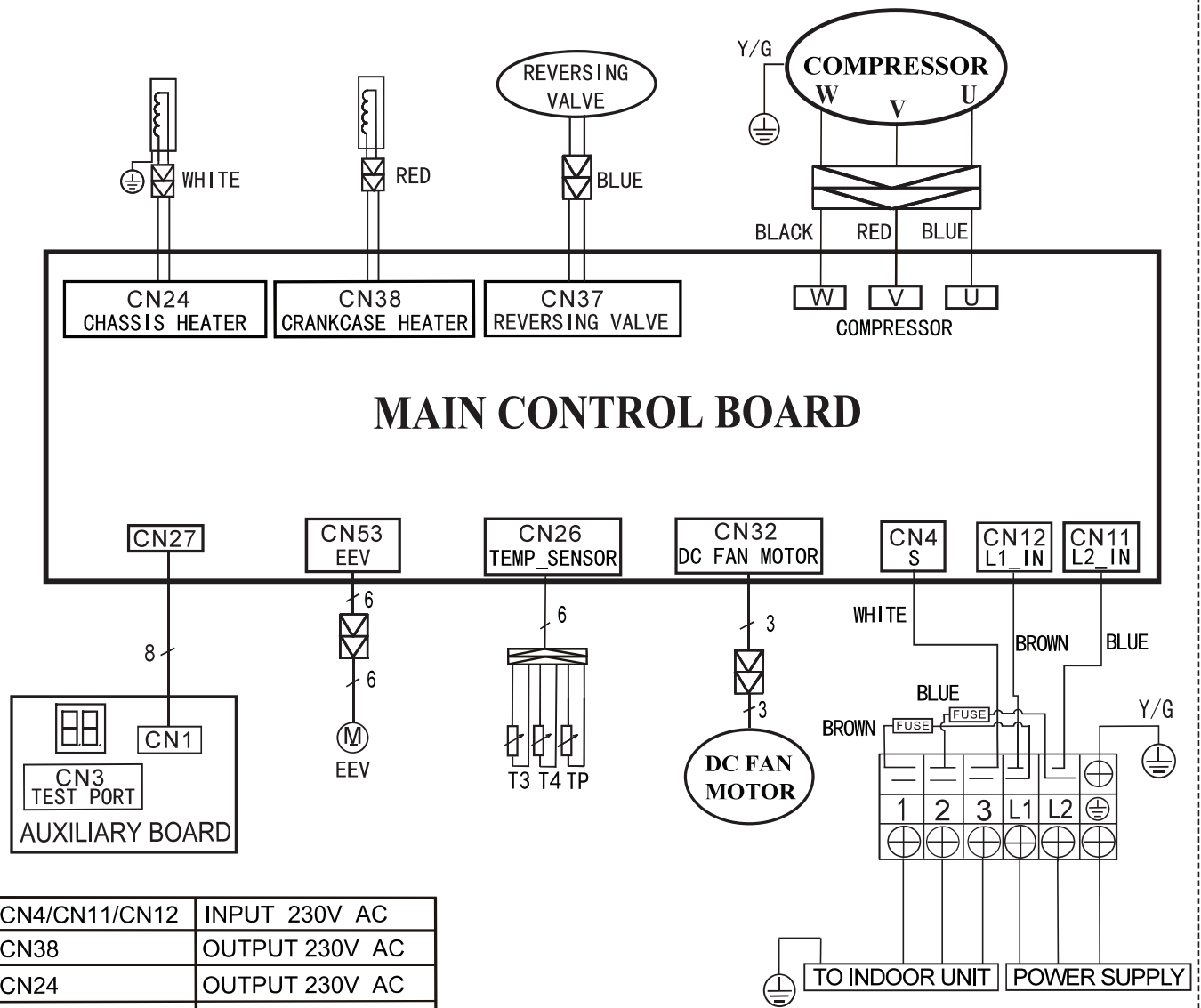

CN4/CN11/CN12	INPUT 230V AC		
CN38	OUTPUT 230V AC		
CN24	OUTPUT 230V AC		
CN37	OUTPUT 230V AC		
CN53	OUTPUT 0~12V DC	EEV	ELECTRONIC EXPANSION VALVE
CN26/CN27/CN3	OUTPUT 0~5V DC	T3	OUTDOOR COIL TEMP SENSOR
CN1	INPUT 0~5V DC	T4	OUTDOOR AMBIENT TEMP SENSOR
CN32/U/V/W	OUTPUT 0~310V AC	TP	COMP DISCHARGE TEMP SENSOR

16022000040331

Outdoor unit printed circuit board diagram: 17122300007152

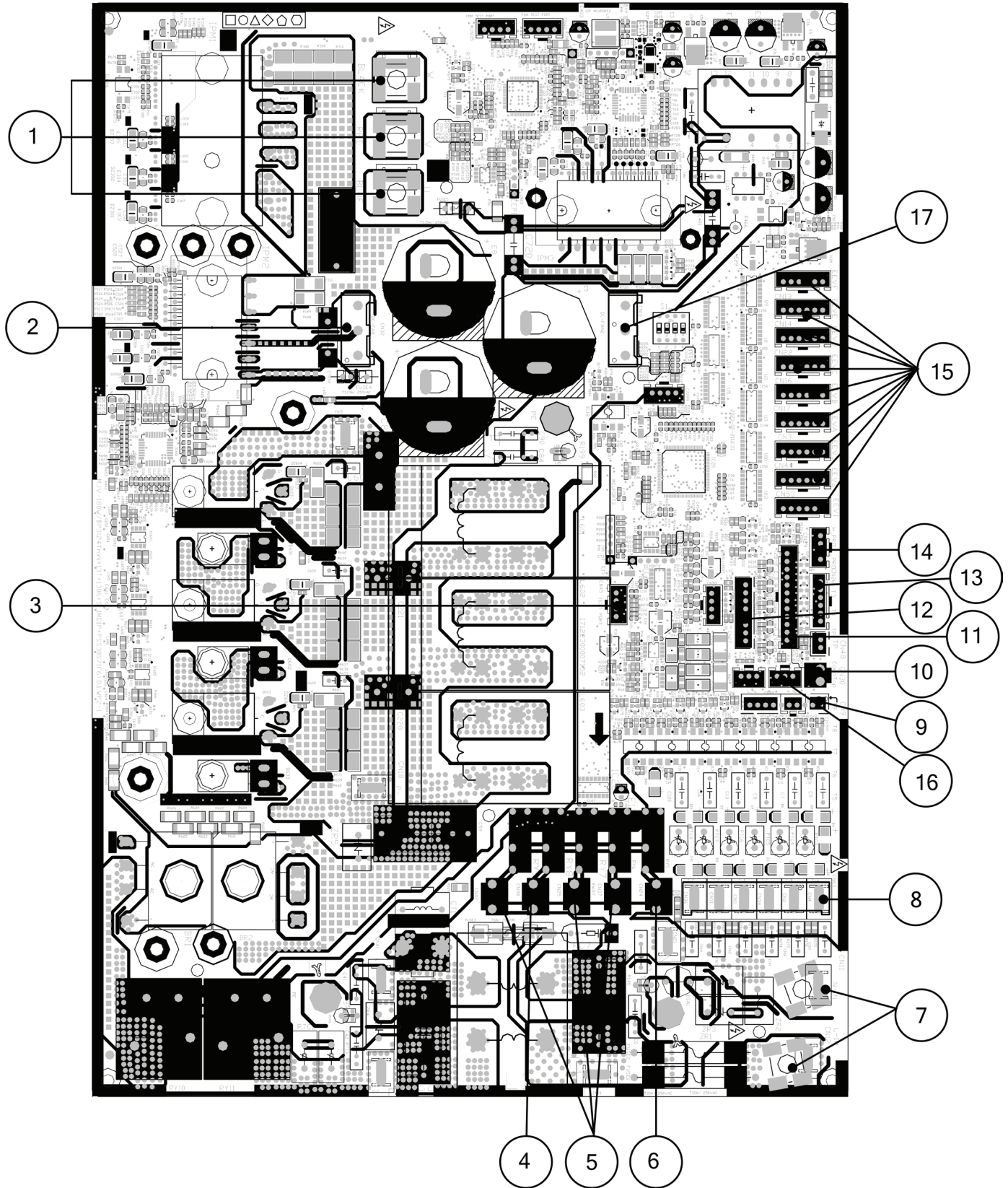

No.	Name	CN#	Meaning
1	COMPRESSOR	W	connect to compressor(Output: 0~310V AC)
		V	
		U	
2	DC-FAN1	CN32	connect to DC fan(Output: 0~310V AC)
3	TESTPORT	CN45	used for testing
4	HEAT_Y	CN38	connect to compressor heater(Output: 230V AC)
5	4-WAY	CN37	connect to 4 way valve 1(Output: 230V AC)
		CN25	connect to 4 way valve 2(Output: 230V AC)
		CN42	connect to 4 way valve 3(Output: 230V AC)
6	HEAT_D	CN24	connect to chassis heater(Output: 230V AC)
7	Power Supply	CN11	N_in: connect to N-line (230V AC input)
		CN12	L_in: connect to L-line (230V AC input)
8	S-A	CN43	S: connect to indoor unit communication(230V AC input)
	S-B		
	S-C		
	S-D		
	S-E		
	S-F		
9	TBH-IN TBH-OUT T3B TF	CN9	connect to cold plate inlet temp. sensor TBH-IN, cold plate outlet temp. sensor TBH-OUT, condenser coil middle temp. sensor T3B, refrigerant tube inlet temp. sensor TF
10	OLP TEMP. SENSOR	CN30	connect to compressor top temp. sensor (Output: 0~5V DC)
11	T2B	CN28	connect to evaporator coil outlet temperature sensor T2B
12	/	CN27	connect to key board CN1
13	T3 T4 TP	CN26	connect to condenser coil temp. sensor T3, ambient temp. sensor T4, exhaust temp. sensor TP(Output: 0~5V DC)
14	H-PRO,L-RPO	CN29	connect to high and low pressure switch(pin1-pin2&pin3-pin4:5VDC pulse wave)

No.	Name	CN#	Meaning
15	EEVA	CN17	connect to electric expansion valve(Output: 0~12V DC)
	EEVB	CN16	
	EEVC	CN22	
	EEVD	CN14	
	EEVE	CN13	
	EEVF	CN1	
	EEV1	CN53	
	EEV2	CN44	
	EEV3	CN3	
16	H_YL	CN49	connect to high pressure sensor
17	DC-FAN2	CN10	connect to DC fan(Output: 0~310V AC)

Note: This section is for reference only. Please take practicality as standard.

Product Features

Contents

1.	Display Function	2
2	Safety Features	3
3.	Basic Functions.....	4
3.1	Abbreviation.....	4
3.2	Fan Mode.....	4
3.3	Cooling Mode	4
3.4	Heating Mode(Heat Pump Units)	5
3.5	Auto-mode.....	7
3.6	Drying Mode	7
3.7	Forced Operation Function	7
3.8	Timer Function	8
3.9	Sleep Function.....	8
3.10	Auto-Restart Function.....	8
3.11	Active Clean function	8
3.12	Follow me(Optional)	8
3.13	8°C Heating(Optional)	8
3.14	Silence (Optional)	8
3.15	ECO function(Optional)	9
3.16	Electrical energy consumption control function(Optional).....	9
3.17	Breeze away function(Optional).....	9
3.18	Wireless control(optional)	9

1. Display Function

Unit display functions









(A)



(B)



(C)

Display		Function
ECO		ECO function (available on select units only)
		when Wireless Control feature is activated(some units)
     	Temperature value	Temperature
		Timer ON is set.
		Activation of , Fresh, Swing, Turbo, ECO, Breeze away, ECO intelligent or Silence
		Timer OFF is set.
		Cancellation of Fresh, Swing, Turbo, ECO, Breeze away, ECO intelligent or Silent
		Defrost
	Active Clean (For Inverter split type) or self-cleaning(For Fixed-speed type)	
	Heating in room temperature under 8°C	

Note: Please select the display function according to your purchase product.

2. Safety Features

Compressor three-minute delay at restart

Compressor functions are delayed for up to ten seconds upon the first startup of the unit, and are delayed for up to three minutes upon subsequent unit restarts.

Automatic shutoff based on discharge temperature

If the compressor discharge temperature exceeds a certain level for a period of time, the compressor ceases operation.

Automatic shutoff based on fan speed

If the indoor fan speed registers below 200RPM or over 2100RPM for an extended period of time, the unit ceases operation and the corresponding error code is displayed on the indoor unit.

Inverter module protection

The inverter module has an automatic shutoff mechanism based on the unit's current, voltage, and temperature. If automatic shutoff is initiated, the corresponding error code is displayed on the indoor unit and the unit ceases operation.

Indoor fan delayed operation

- When the unit starts, the louver is automatically activated and the indoor fan will operate after a period of setting time or the louver is in place.
- If the unit is in heating mode, the indoor fan is regulated by the anti-cold wind function.

Sensor redundancy and automatic shutoff

- If one temperature sensor malfunctions, the air conditioner continues operation and displays the corresponding error code, allowing for emergency use.
- When more than one temperature sensor is malfunctioning, the air conditioner ceases operation.

3. Basic Functions

3.1 Abbreviation

Unit element abbreviations

Abbreviation	Element
T1	Indoor room temperature
T2	Coil temperature of evaporator
T3	Coil temperature of condenser
T4	Outdoor ambient temperature
Tsc	Adjusted setting temperature
TP	Compressor discharge temperature
CDIFTEMP	Cooling shutdown temperature
HDIFTEMP2	Heating shutdown temperature
TCDI1	Enter defrost temperature
TCDE1	Exit defrost temperature1
TCDE2	Exit defrost temperature2 (maintain for a period of time)
TIMING_DEFROST_TIME	Enter defrost time

In this manual, such as CDIFTEMP, HDIFTEMP2, TCDE1, TCDE2, TIMING_DEFROST_TIME...etc., they are well-setting parameter of EEPROM.

3.2 Fan Mode

When fan mode is activated:

- The outdoor fan and compressor cease operation.
- Temperature control is disabled and indoor room temperature is displayed.
- The indoor fan speed can be set to 1%~100%, or auto.
- The louver operations are identical to those in cooling mode.
- Auto fan: In fan-only mode, AC operates the same as auto fan in cooling mode with the temperature set at 24°C(75°F).(Tsc =24°C(75°F))

3.3 Cooling Mode

3.3.1 Compressor Control

Reach the configured temperature:

- 1) When the compressor runs continuously for within 120 minutes.
 - If the following conditions are satisfied, the compressor ceases operation.

- Calculated frequency(fb) is less than minimum limit frequency(FminC).
- Compressor runs at FminC more than 10 minutes
- T1 is lower than or equal to (Tsc-CDIFTEMP-0.5°C(1°F))

Note: CDIFTEMP is EEPROM setting parameter. It is 2°C(4°F) usually.

- 2) When the compressor runs continuously for more than 120 minutes.

- If the following conditions are satisfied, the compressor ceases operation.
 - Calculated frequency(fb) is less than minimum limit frequency(FminC).
 - Compressor runs at FminC more than 10 minutes.
 - T1 is lower than or equal to (Tsc-CDIFTEMP).

Note: CDIFTEMP is EEPROM setting parameter. It is 2°C(4°F) usually.

- 3) If one of the following conditions is satisfied, not judge protective time.

- Compressor running frequency(fr) is more than test frequency(TestFre).
- Compressor running frequency is equal to test frequency, T4 is more than 15°C(59°F) or T4 fault.
- Change setting temperature.
- Turn on/off turbo or sleep function
- Various frequency limit shutdown occurs.

3.3.2 Indoor Fan Control

- 1) In cooling mode, the indoor fan operates continuously. The fan speed can be set to 1%-100%, or auto.
- 2) Auto fan

For DC fan motor units:

- Descent curve
 - When T1-Tsc is lower than 3.5°C(6°F), fan speed reduces to 80%;
 - When T1-Tsc is lower than 1°C(2°F), fan speed reduces to 60%;
 - When T1-Tsc is lower than 0.5°C(1°F), fan speed reduces to 40%;
 - When T1-Tsc is lower than 0°C(0°F), fan speed reduces to 20%;
 - When T1-Tsc is lower than -0.5°C(-1°F), fan speed reduces to 1%.
- Rise curve

- When T1-Tsc is higher than or equal to 0°C(0°F), fan speed increases to 20%;
- When T1-Tsc is higher than or equal to 0.5°C(1°F), fan speed increases to 40%;
- When T1-Tsc is higher than or equal to 1°C(2°F), fan speed increases to 60%;
- When T1-Tsc is higher than or equal to 1.5°C(3°F), fan speed increases to 80%;
- When T1-Tsc is higher than or equal to 4°C(7°F), fan speed increases to 100%.

For AC fan motor units:

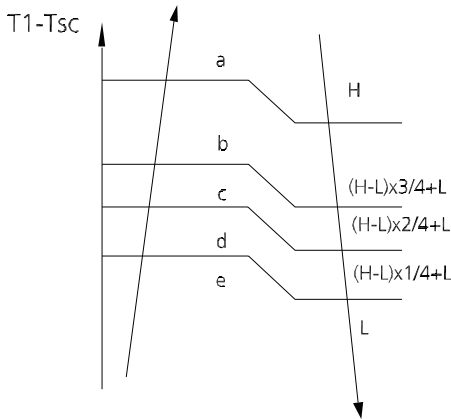

3.3.3 Outdoor Fan Control

- The outdoor unit will be run at different fan speed according to T4 and compressor running frequency..
- For different outdoor units, the fan speeds are different.

3.3.4 Condenser Temperature Protection

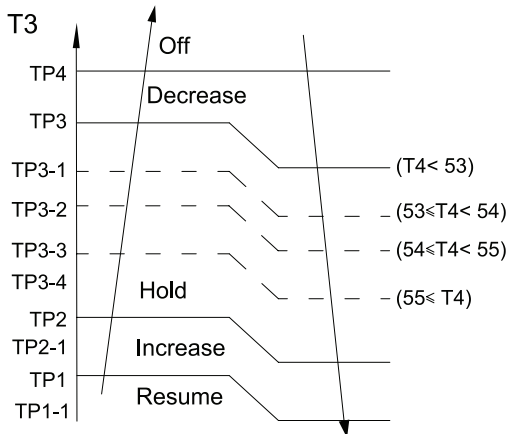

When the condenser temperature exceeds a configured value, the compressor ceases operation.

3.3.5 Evaporator Temperature Protection

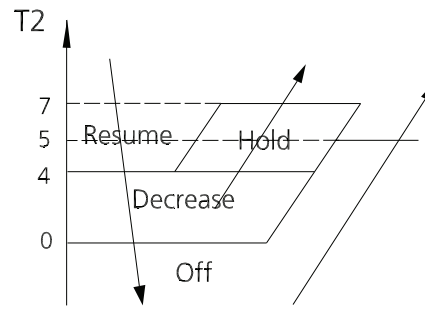

- Off: Compressor stops.
- Decrease: Decrease the running frequency to the lower level per 1 minute.
- Hold: Keep the current frequency.
- Resume: No limitation for frequency.

3.4 Heating Mode(Heat Pump Units)

3.4.1 Compressor Control

1) Reach the configured temperature

- If the following conditions are satisfied, the compressor ceases operation.
 - Calculated frequency(fb) is less than minimum limit frequency(FminH).
 - Compressor runs at FminH more than 10 minutes.
 - T1 is higher than or equal to Tsc+ HDIFTEMP2.

Note: HDIFTEMP2 is EEPROM setting parameter. It is 2°C(4°F) usually.

- If one of the following conditions is satisfied, not judge protective time.
 - Compressor running frequency(fr) is more than test frequency(TestFre).
 - When compressor running frequency is equal to test frequency, T4 is more than 15°C(59°F) or T4 fault.
 - Change setting temperature.
 - Turn on/off turbo or sleep function.

2) When the current is higher than the predefined safe value, surge protection is activated, causing the compressor to cease operations.

3.4.2 Indoor Fan Control:

1) In heating mode, the indoor fan operates continuously. The fan speed can be set to 1%-100%, or mute. And the anti-cold wind function has the priority.

- Anti-cold air function
 - The indoor fan is controlled by the indoor temperature T1 and indoor unit coil temperature T2.

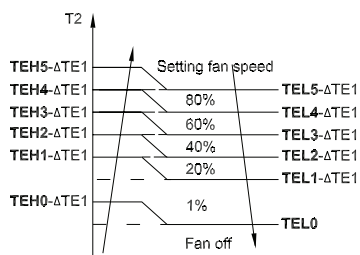

$T1 \geq 19^{\circ}\text{C}(66^{\circ}\text{F})$	$\Delta\text{TE1}=0$
$15^{\circ}\text{C}(59^{\circ}\text{F}) \leq T1 < 19^{\circ}\text{C}(66^{\circ}\text{F})$	$\Delta\text{TE1}=19^{\circ}\text{C}-T1$ ($66^{\circ}\text{F}-T1$)
$T1 < 15^{\circ}\text{C}(59^{\circ}\text{F})$	$\Delta\text{TE1}=4^{\circ}\text{C}(7^{\circ}\text{F})$

2) Auto fan

For DC fan motor units:

- Rise curve
 - When T1-Tsc is higher than $-1.5^{\circ}\text{C}(-3^{\circ}\text{F})$, fan speed reduces to 80%;
 - When T1-Tsc is higher than $0^{\circ}\text{C}(0^{\circ}\text{F})$, fan speed reduces to 60%;
 - When T1-Tsc is higher than $0.5^{\circ}\text{C}(1^{\circ}\text{F})$, fan speed reduces to 40%;
 - When T1-Tsc is higher than $1^{\circ}\text{C}(2^{\circ}\text{F})$, fan speed reduces to 20%.
- Descent curve
 - When T1-Tsc is lower than or equal to $0.5^{\circ}\text{C}(1^{\circ}\text{F})$, fan speed increases to 40%;
 - When T1-Tsc is lower than or equal to $0^{\circ}\text{C}(0^{\circ}\text{F})$, fan speed increases to 60%;
 - When T1-Tsc is lower than or equal to $-1.5^{\circ}\text{C}(-3^{\circ}\text{F})$, fan speed increases to 80%;
 - When T1-Tsc is lower than or equal to $-3^{\circ}\text{C}(5^{\circ}\text{F})$, fan speed increases to 100%.

For AC fan motor units:

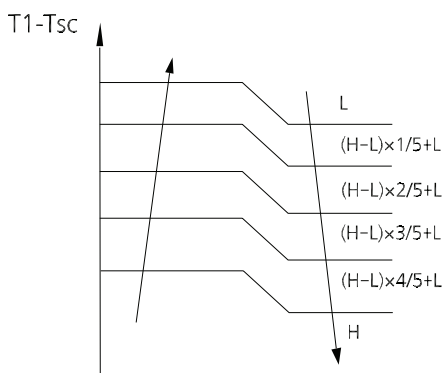

3.4.3 Outdoor Fan Control:

- The outdoor unit will be run at different fan speed according to T4 and compressor running frequency.
- For different outdoor units, the fan speeds are different.

3.4.4 Defrosting mode

- If any one of the following conditions is satisfied, AC will enter the defrosting mode.

After the compressor starts up and keeps running, take the lowest temp of T3 (from the period 7th minutes to 12nd minutes) as T30.

Condition 1: If the compressor cumulate running time is up to 29 minutes and $T3 < \text{TCDI1}$ and $T3 \leq \text{T30-T30SUBT30ONE}$ and $T4 < -22^{\circ}\text{C}(\text{DEFROST_T4_ADD})$

Condition 2: If the compressor cumulate running time is up to 35 minutes and $T3 < \text{TCDI2}$ and $T3 \leq \text{T30-T30SUBT30TWO}$ and $T4 < -22^{\circ}\text{C}(\text{DEFROST_T4_ADD})$

Condition 3: If the compressor cumulate running time is up to 29 minutes and $T3 < -24$ (TCDI3_ADD) for 3 minutes. and $T4 > -22^{\circ}\text{C}(\text{DEFROST_T4_ADD})$

Condition 4: For the model active this condition If the compressor cumulate running time is up to 120 minutes and $T3 < -15^{\circ}\text{C}$ and $T4 < -22^{\circ}\text{C}$

Condition 5: This is just for the first time defrost after power on condition, on the scenario when first time defrost or power off and power back or turn on from standby need to check the ice accumulate situation (the defrost time reckon reset), when compressor cumulate running time is up to 30 minutes $T4 - T3 > (0.5T4 + \text{KDELTT_ADD})$ and $T3 < \text{TCDIN5_ADD}$, $T4 < -22^{\circ}\text{C}$,

Condition 6: For the model active this condition If the compressor cumulate running time is up to $\text{TIMING_DEFROST_TIME}$ (Hour) and $T4 \leq -22^{\circ}\text{C}(\text{DEFROST_T4_ADD})$, the T4 without malfunction

Condition 7: When T3 or T4 lower than -3°C (last for 30 seconds) cumulate running for ($\text{EE_TIME_DEFROST7_ADD}$) minutes with $Ts - T1 \leq 5^{\circ}\text{C}$ (not need based on T30 keep running with minimum 10th minutes)

Condition 8: When T3 or T4 lower than -3°C (last for 30 seconds) cumulate running for ($\text{EE_TIME_DEFROST7_ADD} + 30$) minutes (not need based on T30 keep running with minimum 10th minutes)

- In defrosting mode, the compressor continues to run, the indoor and outdoor motor will cease operation, the defrost light of the indoor unit will turn on, and the "df" symbol is displayed.
- Condition 1~5, If any one of the following conditions is satisfied, defrosting ends and the machine switches to normal heating mode:

- T3 rises above TCDE1.
- T3 maintained above TCDE2 for 80 seconds.
- Unit runs for 15 minutes consecutively in defrosting mode.
- Condition 6, if any one of the following conditions is satisfied, defrosting ends and the machine switches to normal heating mode:
 - Unit runs for 10 minutes consecutively in defrosting mode.
 - T3 rises above 10°C(50°F).
- Condition 7~8, If any one of the following conditions is satisfied, defrosting ends and the machine switches to normal heating mode:
 - T3 rises above TCDE1+4°C/7°F.
 - T3 maintained above TCDE2+4°C/7°F for 80 seconds.
 - Unit runs for 15 minutes consecutively in defrosting mode.

3.4.5 Evaporator Temperature Protection

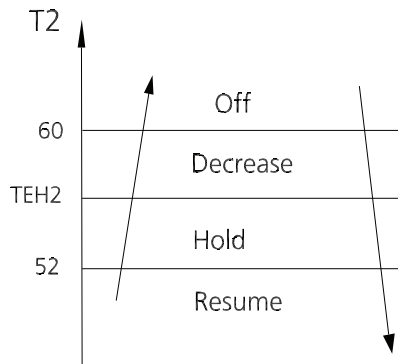

- Off: Compressor stops.
- Decrease: Decrease the running frequency to the lower level per 20 seconds.
- Hold: Keep the current frequency.
- Resume: No limitation for frequency.

3.5 Auto-mode

- This mode can be selected with the remote controller and the setting temperature can be changed between 16°C~30°C(60°F~86°F).
- In auto mode, the machine selects cooling, heating, auto-drying or fan-only mode on the basis of T1, Ts, T4 and relative humidity.

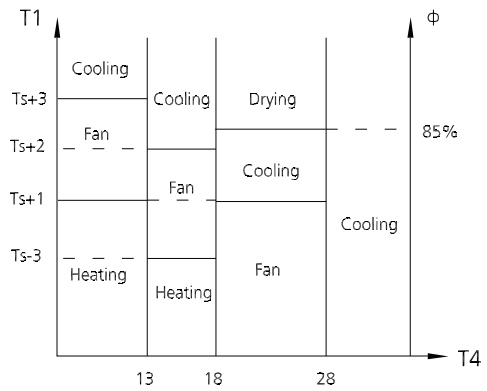

- If the setting temperature is modified, the machine selects a new running function.

4 Drying mode

- In drying mode, AC operates the same as auto fan in cooling mode.
- All protections are activated and operate the same as they do that in cooling mode.
- Low Room Temperature Protection

If the room temperature is lower than 10°C(50°F), the compressor ceases operations and does not resume until room temperature exceeds 12°C(54°F).

3.7 Forced operation function

- Forced cooling mode:

The compressor and outdoor fan continue to run(fixed at rated frequency), and the indoor fan runs at rated speed. After running for 30 minutes, the AC will switch to auto mode with a preset temperature of 24°C(76°F).

- Forced auto mode:

Forced auto mode operates the same as normal auto mode with a preset temperature of 24°C(76°F).

- The unit exits forced operation when it receives the following signals:
 - Switch on
 - Switch off
 - Timer on
 - Timer off
 - Sleep mode
 - Follow me
 - Changes in:
 - mode
 - fan speed
 - setting temperature

- Forced defrosting mode:
 - Press AUTO/COOL button continuously for 5s under forced cooling mode to enter this mode.
 - Indoor fan will stop, defrosting lamp will light on.
 - Quit this mode and turn off the unit when:
 - quit normal defrosting
 - turn off by RC
 - Press AUTO/COOL button continuously for 5s again

3.8 Timer function

- Timing range is 24 hours.
- Timer on. The machine will turn on automatically when reaching the setting time.
- Timer off. The machine will turn off automatically when reaching the setting time.
- Timer on/off. The machine will turn on automatically when reaching the setting "on" time, and then turn off automatically when reaching the setting "off" time.
- Timer off/on. The machine will turn off automatically when reaching the setting "off" time, and then turn on automatically when reaching the setting "on" time.
- The timer function will not change the AC current operation mode. Suppose AC is off now, it will not start up firstly after setting the "timer off" function. And when reaching the setting time, the timer LED will be off and the AC running mode has not been changed.
- The setting time is relative time.
- The AC will quit the timer function when it has malfunction

3.9 Sleep function

- The sleep function is available in cooling, heating, or auto mode.
- The operational process for sleep mode is as follows:
 - When cooling, the temperature rises 1°C/2°F (to not higher than 30°C/86°F) every hour. After 2 hours, the temperature stops rising and the indoor fan is fixed at low speed.
 - When heating, the temperature decreases 1°C/2°F (to not lower than 16°C/61°F) every hour. After 2 hours, the temperature stops decreasing and the indoor fan is fixed at low speed. Anti-cold wind function takes priority.
- The operating time for sleep mode is 8 hours, after which, the unit exits this mode.
- The timer setting is available in this mode.

3.10 Auto-Restart function

- The indoor unit has an auto-restart module that allows the unit to restart automatically. The module automatically stores the current settings and, in the case of a sudden power failure, will restore those setting automatically within 3 minutes after power returns.
- If there is a power failure while the unit is running, the compressor starts 3 minutes after the unit restarts. If the unit was already off before the power failure, the unit stands by.

3.11 Active Clean function

- The Active Clean Technology washes away dust, mold, and grease that may cause odors when it adheres to the heat exchanger by automatically freezing and then rapidly thawing the frost. The internal wind wheel then keeps operating to blow-dry the evaporator, thus preventing the growth of mold and keeping the inside clean.
- When this function is turned on, the indoor unit display window appears "CL", after 20 to 130 minutes, the unit will turn off automatically and cancel Active Clean function.

3.12 Follow me(Optional)

- If you press "Follow Me" on the remote, the indoor unit will beep. This indicates the follow me function is active.
- Once active, the remote control will send a signal every 3 minutes, with no beeps. The unit automatically sets the temperature according to the measurements from the remote control.
- The unit will only change modes if the information from the remote control makes it necessary, not from the unit's temperature setting.
- If the unit does not receive a signal for 7 minutes or you press "Follow Me," the function turns off. The unit regulates temperature based on its own sensor and settings.

3.13 8°C Heating(Optional)

In heating mode, the temperature can be set to as low as 8°C, preventing the indoor area from freezing if unoccupied during severe cold weather.

3.14 Silence (Optional)

Press "Silence" on the remote control to enable the SILENCE function. While this function is active, the indoor unit will run at faint breeze(1% fan speed), which reduces

noise to the lowest possible level.

3.15 ECO function (Optional)

- Used to enter the energy efficient mode.
 - Under cooling mode, press ECO button, the remote controller will adjust the temperature automatically to 24°C/75°F, fan speed of Auto to save energy (but only if the set temperature is less than 24°C/75°F). If the set temperature is more than 24°C/75°F and 30°C/86°F, press the ECO button, the fan speed will change to Auto, the set temperature will remain unchanged.
- When AC receives signals, such as switch off, Turbo operation, Silence operation, Self clean operation, Forced cooling operation, mode setting, Sleeping mode, or adjusting the set temperature to less than 24°C/76°F, it will quit the ECO operation.
- Operation time in ECO mode is 8 hours. After 8 hours the AC quits this mode.
- When there's any one temperature sensor in malfunction, the AC will quit ECO mode.
- Indoor fan will run at auto fan when enter into the ECO mode. The setting temperature and setting fan speed can be changed through remote controller signal.

3.16 Electrical energy consumption control function (Optional)

Press the "Gear" button on remote controller to enter the energy efficient mode in a sequence of following:

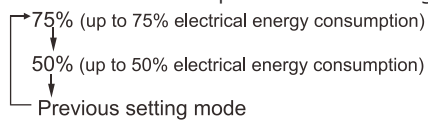

Turn off the unit or activate ECO, sleep, Super cool, 8°C Heating, Silence or self clean function will quit this function.

3.17 Breeze Away function (Optional)

- This feature avoids direct airflow blowing on the body and makes you feel indulging in silky coolness.
- NOTE: This feature is available under cooling mode, fan-only mode and drying mode.

3.18 Wireless Control (Optional)

- Wireless control allows you to control your air conditioner using your mobile phone and a Wireless connection.
- For the USB device access, replacement, maintenance operations must be carried out by professional staff.

Maintenance

Contents

1.	First Time Installation Check.....	2
2	Refrigerant Recharge	4
3	Re-Installation	5
3.1	Indoor Unit.....	5
3.2	Outdoor Unit.....	7

1. First Time Installation Check

Air and moisture trapped in the refrigerant system affects the performance of the air conditioner by:

- Increasing pressure in the system.
- Increasing the operating current.
- Decreasing the cooling or heating efficiency.
- Congesting the capillary tubing due to ice build-up in the refrigerant circuit.
- Corroding the refrigerant system.

To prevent air and moisture from affecting the air conditioner's performance, the indoor unit, as well as the pipes between the indoor and outdoor unit, must be leak tested and evacuated.

Leak test (soap water method)

Use a soft brush to apply soapy water or a neutral liquid detergent onto the indoor unit connections and outdoor unit connections. If there is gas leakage, bubbles will form on the connection.

Air purging with vacuum pump

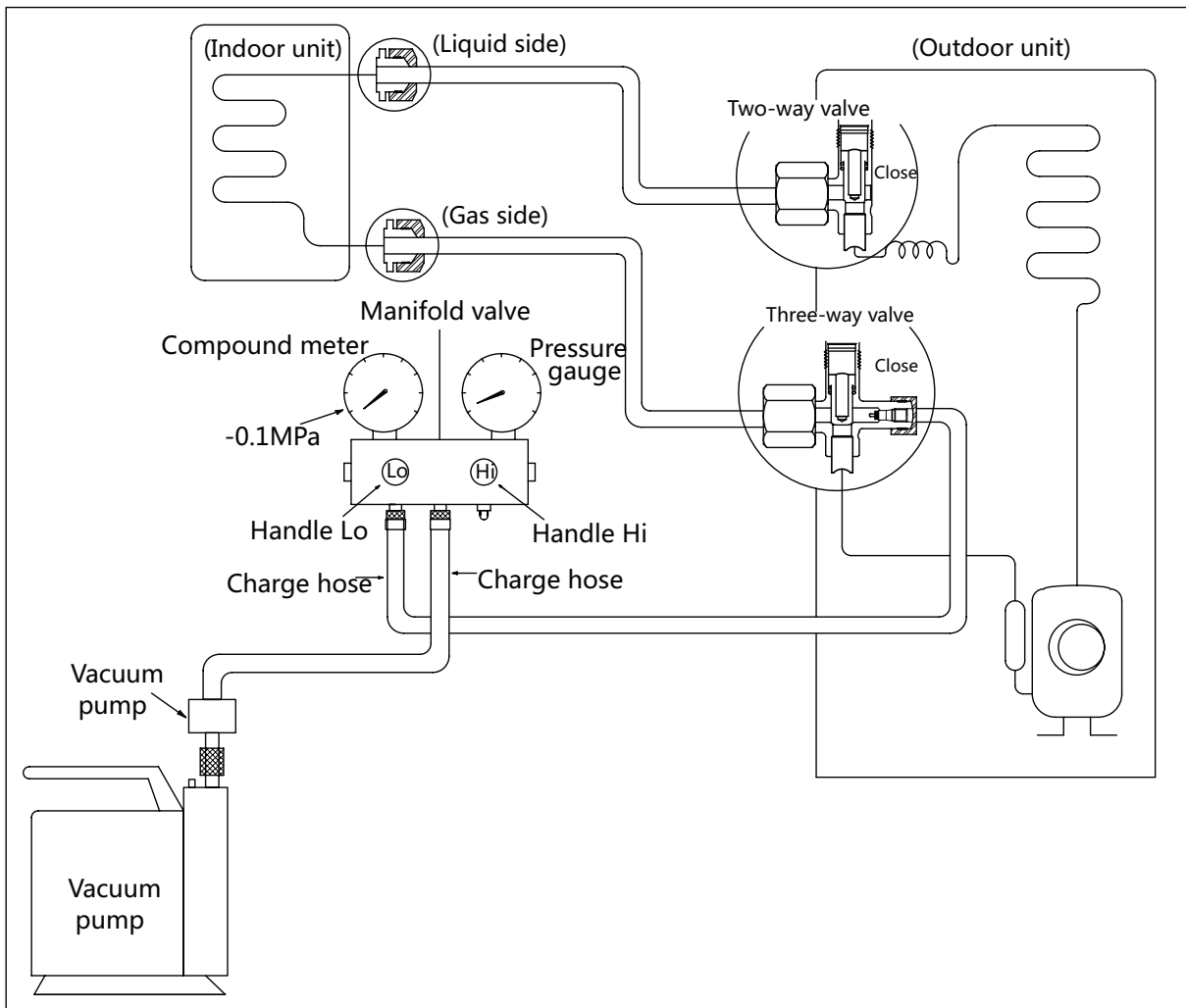

Procedure:

1. Tighten the flare nuts of the indoor and outdoor units, and confirm that both the 2- and 3-way valves are closed.
2. Connect the charge hose with the push pin of Handle Lo to the gas service port of the 3-way valve.
3. Connect another charge hose to the vacuum pump.
4. Fully open the Handle Lo manifold valve.
5. Using the vacuum pump, evacuate the system for 30 minutes.
 - a. Check whether the compound meter indicates -0.1 MPa (14.5 Psi).
 - If the meter does not indicate -0.1 MPa (14.5 Psi) after 30 minutes, continue evacuating for an additional 20 minutes.
 - If the pressure does not achieve -0.1 MPa (14.5 Psi) after 50 minutes, check for leakage.
 - b. If the pressure successfully reaches -0.1 MPa (14.5 Psi), fully close the Handle Lo valve, then cease vacuum pump operations.
6. Loosen the flare nut of the 3-way valve for 6 or 7 seconds and then tighten the flare nut again.
 - a. Confirm the pressure display in the pressure indicator is slightly higher than the atmospheric pressure.
 - b. Remove the charge hose from the 3-way valve.
7. Fully open the 2- and 3-way valves and tighten the cap of the 2- and 3-way valves.

2. Refrigerant Recharge

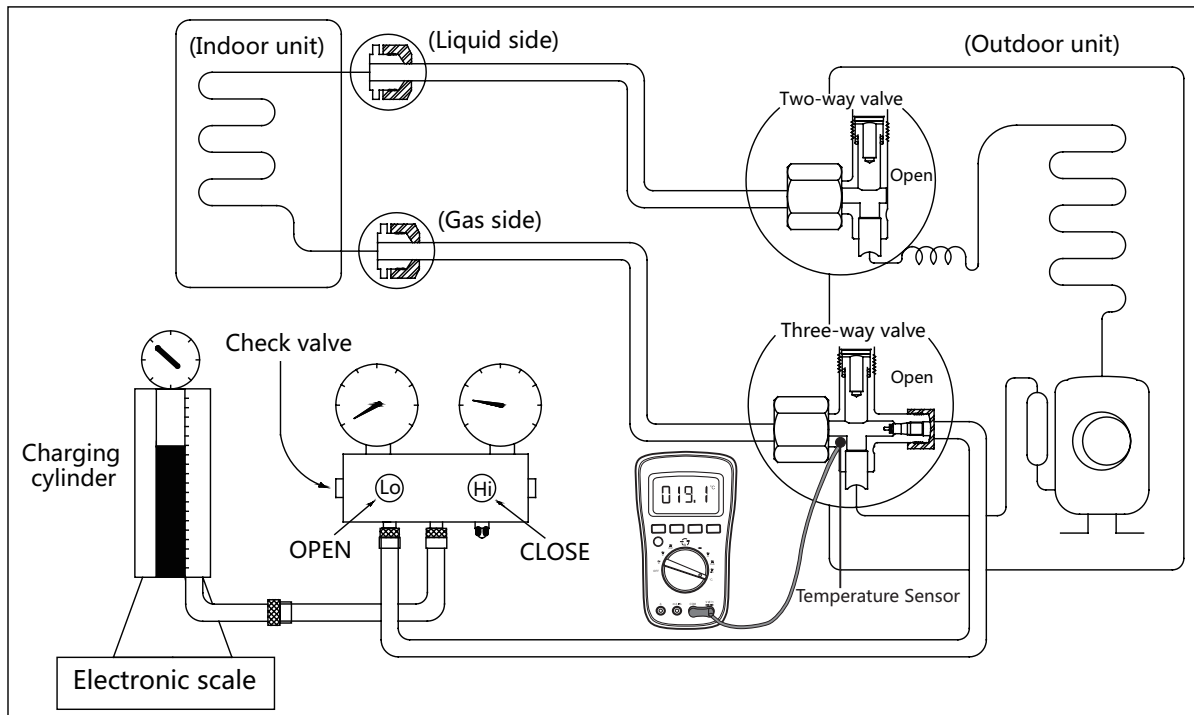

Procedure:

1. Close both 2- and 3-way valves.
2. Slightly connect the Handle Lo charge hose to the 3-way service port.
3. Connect the charge hose to the valve at the bottom of the cylinder.
4. If the refrigerant is R410A/R32, invert the cylinder to ensure a complete liquid charge.
5. Open the valve at the bottom of the cylinder for 5 seconds to purge the air in the charge hose, then fully tighten the charge hose with push pin Handle Lo to the service port of 3-way valve..
6. Place the charging cylinder onto an electronic scale and record the starting weight.
7. Fully open the Handle Lo manifold valve, 2- and 3-way valves.
8. Operate the air conditioner in cooling mode to charge the system with liquid refrigerant.
9. When the electronic scale displays the correct weight (refer to the gauge and the pressure of the low side to confirm, the value of pressure refers to chapter Appendix), turn off the air conditioner, then disconnect the charge hose from the 3-way service port immediately..
10. Mount the caps of service port and 2- and 3-way valves.
11. Use a torque wrench to tighten the caps to a torque of 18 N.m.
12. Check for gas leakage.

3. Re-Installation

3.1 Indoor Unit

Collecting the refrigerant into the outdoor unit

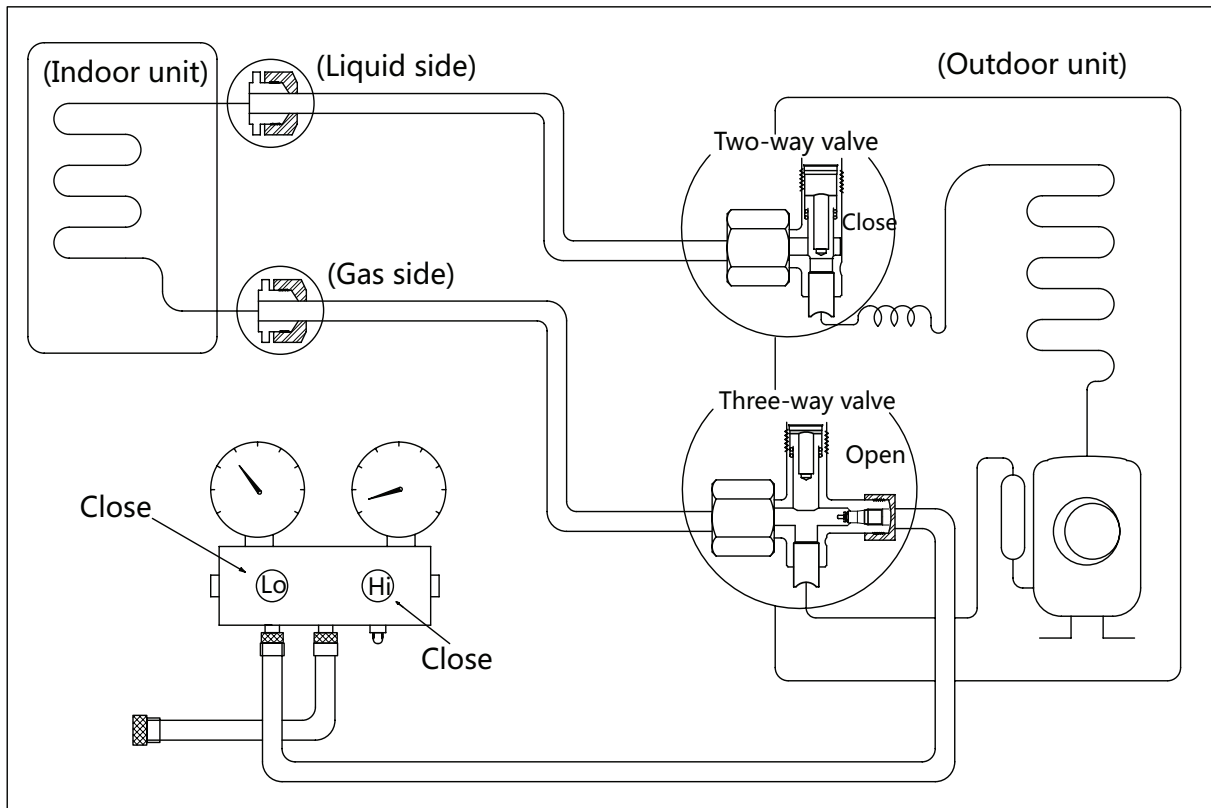

Procedure:

1. Confirm that the 2- and 3-way valves are opened.
2. Connect the charge hose with the push pin of Handle Lo to the 3-way valve's gas service port.
3. Open the Handle Lo manifold valve to purge air from the charge hose for 5 seconds and then close it quickly.
4. Close the 2-way valve.
5. Operate the air conditioner in cooling mode. Cease operations when the gauge reaches 0.1 MPa (14.5 Psi).
6. Close the 3-way valve so that the gauge rests between 0.3 MPa (43.5 Psi) and 0.5 MPa (72.5 Psi).
7. Disconnect the charge set and mount the caps of service port and 2- and 3-way valves.
8. Use a torque wrench to tighten the caps to a torque of 18 N.m.
9. Check for gas leakage.

Air purging with vacuum pump

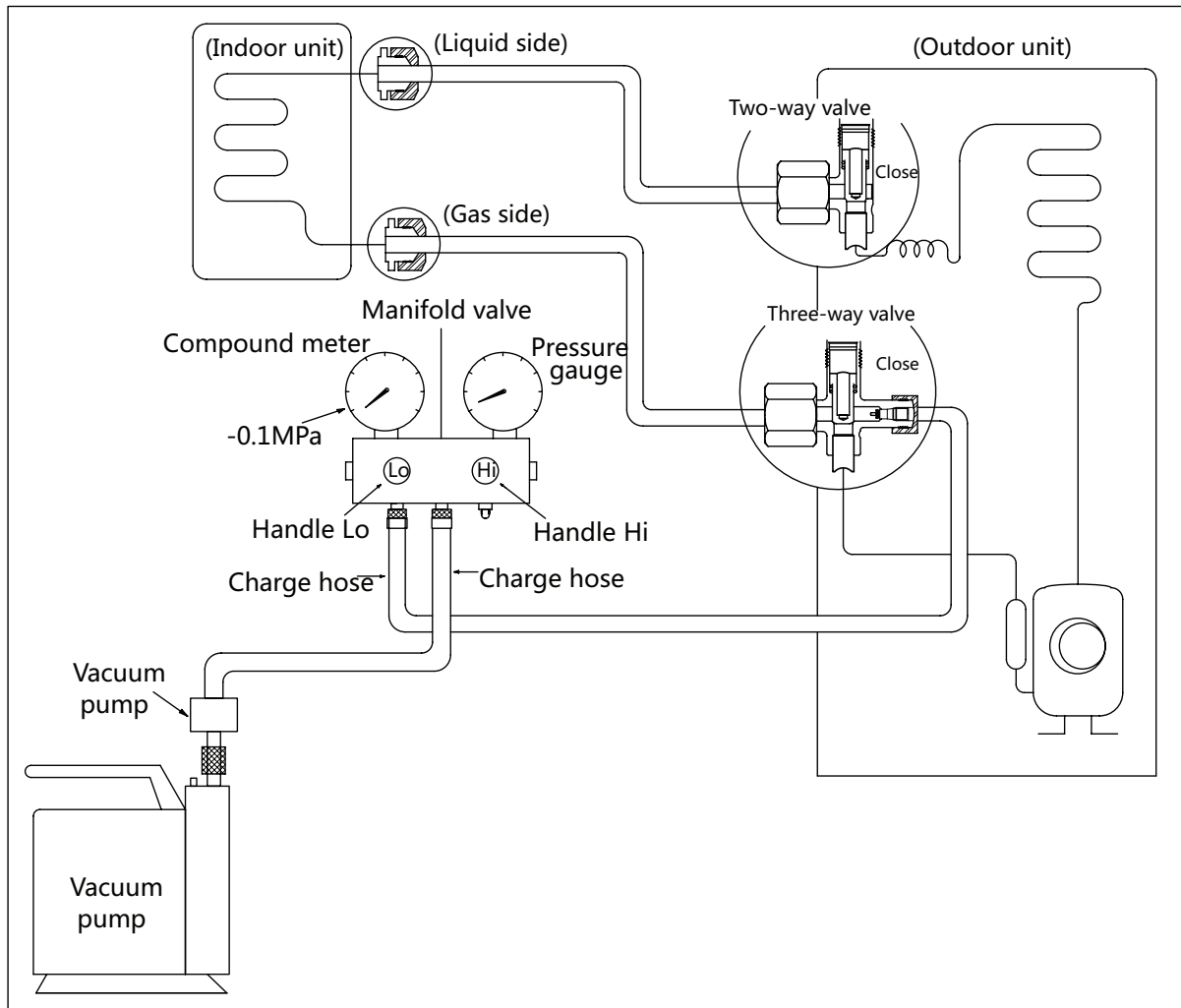

Procedure:

1. Tighten the flare nuts of the indoor and outdoor units, and confirm that both the 2- and 3-way valves are closed.
2. Connect the charge hose with the push pin of Handle Lo to the gas service port of the 3-way valve.
3. Connect another charge hose to the vacuum pump.
4. Fully open the Handle Lo manifold valve.
5. Using the vacuum pump, evacuate the system for 30 minutes.
 - a. Check whether the compound meter indicates -0.1 MPa (14.5 Psi).
 - If the meter does not indicate -0.1 MPa (14.5 Psi) after 30 minutes, continue evacuating for an additional 20 minutes.
 - If the pressure does not achieve -0.1 MPa (14.5 Psi) after 50 minutes, check for leakage.
 - b. If the pressure successfully reaches -0.1 MPa (14.5 Psi), fully close the Handle Lo valve, then cease vacuum pump operations.
6. Wait for 5 minutes then check whether the gauge needle moves after turning off the vacuum pump. If the gauge needle moves backward, check whether there is gas leakage.
 - a. Loosen the flare nut of the 3-way valve for 6 or 7 seconds and then tighten the flare nut again.
 - Confirm the pressure display in the pressure indicator is slightly higher than the atmospheric pressure.
 - b. Remove the charge hose from the 3-way valve.
7. Fully open the 2- and 3-way valves and tighten the cap of the 2- and 3-way valves.

3.2 Outdoor Unit

Evacuation for the whole system

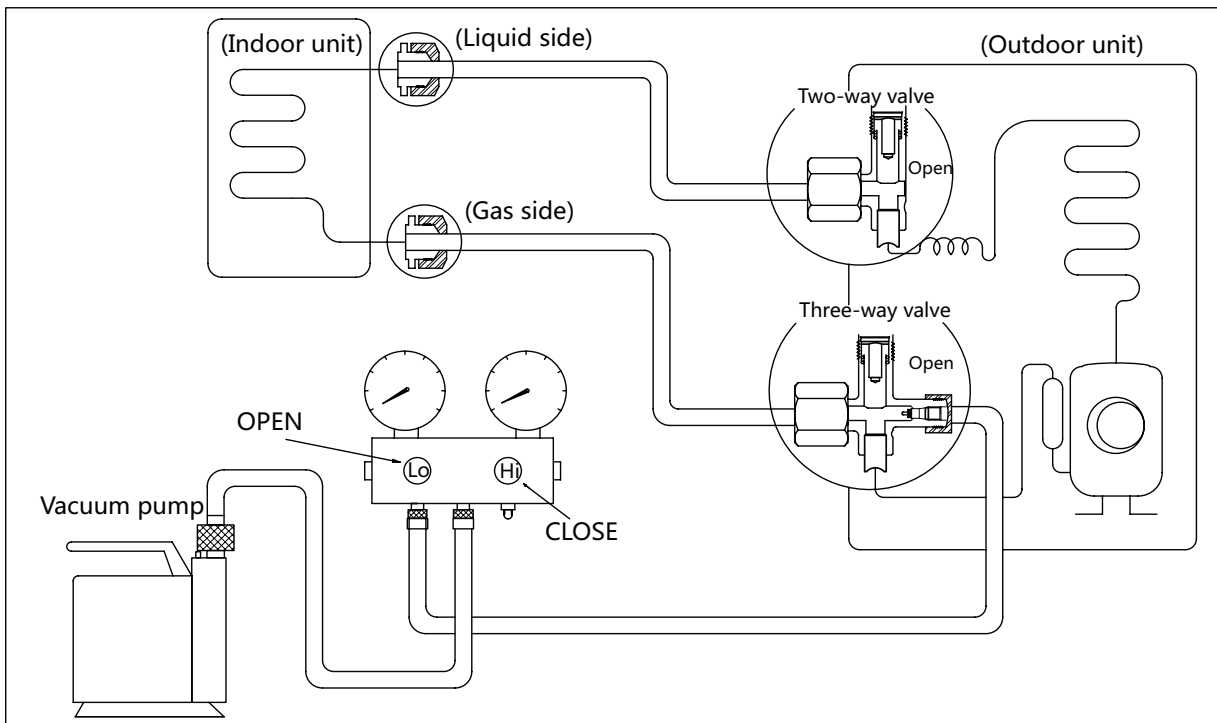

Procedure:

1. Confirm that the 2- and 3-way valves are opened.
2. Connect the vacuum pump to the 3-way valve's service port.
3. Evacuate the system for approximately one hour. Confirm that the compound meter indicates -0.1 MPa (14.5Psi).
4. Close the valve (Low side) on the charge set and turn off the vacuum pump.
5. Wait for 5 minutes then check whether the gauge needle moves after turning off the vacuum pump. If the gauge needle moves backward, check whether there is gas leakage.
6. Disconnect the charge hose from the vacuum pump.
7. Mount the caps of service port and 2- and 3-way valves.
8. Use a torque wrench to tighten the caps to a torque of 18 N.m.

Refrigerant charging

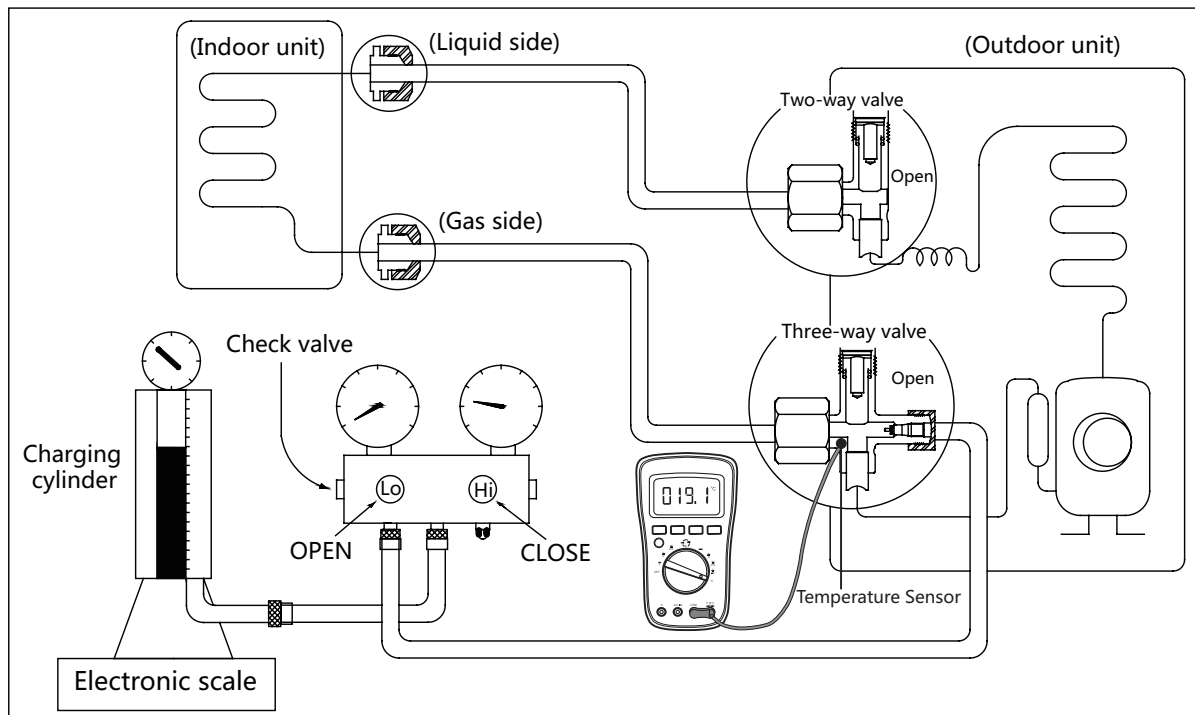

Procedure:

1. Close both 2- and 3-way valves.
2. Slightly connect the Handle Lo charge hose to the 3-way service port.
3. Connect the charge hose to the valve at the bottom of the cylinder.
4. If the refrigerant is R410A/R32, invert the cylinder to ensure a complete liquid charge.
5. Open the valve at the bottom of the cylinder for 5 seconds to purge the air in the charge hose, then fully tighten the charge hose with push pin Handle Lo to the service port of 3-way valve..
6. Place the charging cylinder onto an electronic scale and record the starting weight.
7. Fully open the Handle Lo manifold valve, 2- and 3-way valves.
8. Operate the air conditioner in cooling mode to charge the system with liquid refrigerant.
9. When the electronic scale displays the correct weight (refer to the gauge and the pressure of the low side to confirm, the value of pressure refers to chapter Appendix), turn off the air conditioner, then disconnect the charge hose from the 3-way service port immediately..
10. Mount the caps of service port and 2- and 3-way valves.
11. Use a torque wrench to tighten the caps to a torque of 18 N.m.
12. Check for gas leakage.

Note: 1. Mechanical connectors used indoors shall comply with local regulations.

2. When mechanical connectors are reused indoors, sealing parts shall be renewed. When flared joints are reused indoors, the flare part shall be re-fabricated.

Troubleshooting

Contents

1. Safety Caution	3
2. General Troubleshooting.....	4
2.1 Error Display (Indoor Unit)	4
2.2 Error Display (Outdoor Unit with auxiliary board)	6
3. Outdoor Unit Point Check Function	7
4. Complain Record Form	8
5. Information Inquiry&Setting	10
6. Error Diagnosis and Troubleshooting Without Error Code.....	15
6.1 Remote maintenance	15
6.2 Field maintenance.....	16
7. Quick Maintenance by Error Code.....	21
8. Troubleshooting by Error Code.....	23
8.1 EH00/ EH0A(IDU EEPROM malfunction or IDU EEPROM parameter error) diagnosis and solution	23
8.2 EC51(ODU EEPROM parameter error) diagnosis and solution	24
8.3 EL01(IDU & ODU communication error) diagnosis and solution	25
8.4 EH02(Zero crossing detection error) diagnosis and solution	27
8.5 EH03(The Indoor fan speed is operating outside of normal range) diagnosis and solution	28
8.6 EC07/EC71(The outdoor fan speed is operating outside of normal range or Over current failure of ODU DC fan motor) diagnosis and solution	30
8.7 EH60/EH61(Open circuit or short circuit of indoor temperature sensor(T1, T2)) diagnosis and solution.....	32
8.8 EC52/EC53/EC54/EC56/EC50(Open circuit or short circuit of outdoor temperature sensor(T3, T4, TP, T2B)) diagnosis and solution	33
8.9 EL0C(System lacks refrigerant) diagnosis and solution	34

Troubleshooting

Contents

8.10	EH0b(IDU main control board and display board communication error) diagnosis and solution	35
8.11	PC08(Current overload protection)/PC42(Compressor start failure of outdoor unit)/PC44(ODU zero speed protection) /PC46(Compressor speed has been out of control)/PC49(Compressor overcurrent failure) diagnosis and solution	36
8.12	FHCC(Refrigerant sensor error) or EHC3(Refrigerant sensor is out of range) diagnosis	37
8.13	EHC1(Refrigerant sensor detects leakage) or EHC2(Refrigerant sensor is out of range and leakage is detected) diagnosis and solution	38
8.14	PC00(ODU IPM module protection) diagnosis and solution	39
8.15	PC01(ODU voltage protection)/PC10(ODU low AC voltage protection)/PC11(ODU main control board DC bus high voltage protection)/PC12(ODU main control board DC bus low voltage protection/341 MCE error) diagnosis and solution	40
8.16	PC02/LC06 (Compressor top(or IPM) temp. protection/Refrigerant sensor error) diagnosis and solution	41
8.17	PC04(Compressor feedback protection) diagnosis and solution	42
8.18	PC03/PC30/PC31(Pressure protection(low or high pressure) diagnosis and solution	43
8.19	IDUs mode conflict (match with multi outdoor unit)	46
8.20	Low temperature protection	46
8.21	PC0A(High temperature protection of condenser) diagnosis and solution	47
8.22	PC0F(PFC module protection) diagnosis and solution	48
8.23	PC40(Communication error between outdoor main chip and compressor driven chip) diagnosis and solution	49
8.24	PC06(Discharge temperature protection of compressor) diagnosis and solution	50
8.25	EC72(Lack phase failure of ODU DC fan motor) diagnosis and solution	51
8.26	PC43(ODU compressor lack phase protection) diagnosis and solution	52
8.27	PC45(ODU IR chip drive failure) diagnosis and solution	53

9. Check Procedures

1. Safety Caution

⚠ WARNING

Be sure to turn off all power supplies or disconnect all wires to avoid electric shock. While checking indoor/outdoor PCB, please equip oneself with antistatic gloves or wrist strap to avoid damage to the board.

⚠ WARNING

Electricity remains in capacitors even when the power supply is off. Ensure the capacitors are fully discharged before troubleshooting.

NOTE: If using the inverter test tool maintenance, remove the big handle, take out the detection cable, take out female end of the cable and connect the inverter test tool. After the maintenance is completed, insert the female end back into the port.

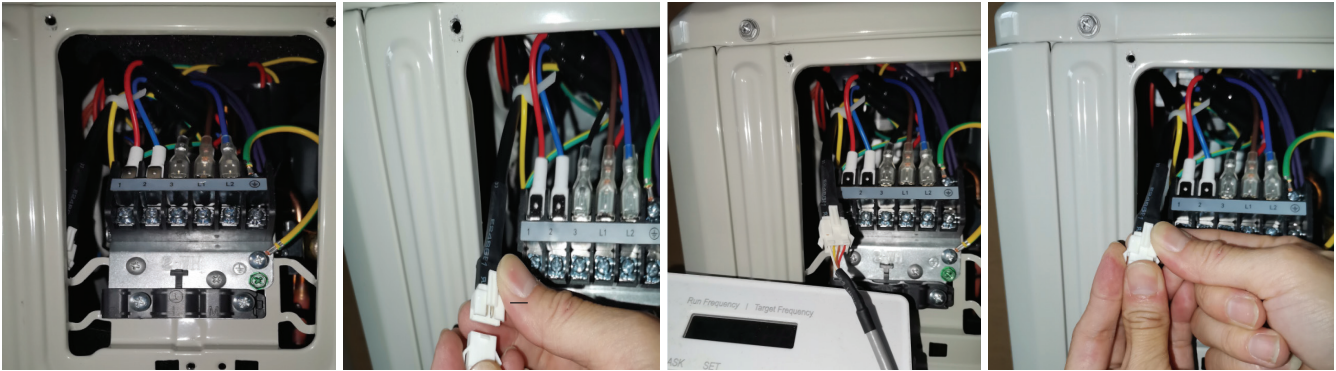

Note: This picture is for reference only. Actual appearance may vary.

2. General Troubleshooting

2.1 Error Display (Indoor Unit)

When the indoor unit encounters a recognized error on different models, an error code will be displayed; These error codes are described in the following tables:

Display	Information	Solution
dF	Defrost	Normal Display, not error code
CL	Active clean	
FP	Heating in room temperature under 8°C	
FC	Forced cooling	
AP	AP mode of WIFI connection	
CP	Remote switched off	
EH00	IDU EEPROM malfunction	TS23
EH0A	Indoor EEPROM parameter error	TS23
EL01	IDU & ODU communication error	TS25
EH02	Zero-crossing signal detection error	TS27
EH03	IDU fan speed out of control	TS28
ECS1	ODU EEPROM parameter error	TS24
ECS2	ODU coil temp. sensor (T3) error	TS33
ECS3	ODU ambient temp. sensor (T4) error	TS33
ECS4	COMP. discharge temp. sensor (TP) error	TS33
ECS6	IDU coil outlet temp. sensor (T2B) error(Multi-zone)	TS33
EH60	IDU room temp. sensor (T1) error	TS32
EH61	IDU pipe temp. (T2) sensor error	TS32
ECO7	ODU fan speed out of control	TS30
EH0b	IDU main control board and display board communication error	TS35
FHCC	Refrigerant sensor error	TS37
EH01	Refrigerant sensor detects leakage	TS38
EH02	Refrigerant sensor is out of range and leakage is detected	TS38
EH03	Refrigerant sensor is out of range	TS37
ECC1	Other IDU refrigerant sensor detects leakage (Multi-zone)	TS38
ELOC	System lacks refrigerant	TS34
PE00	ODU IPM module protection	TS39

PC01	ODU voltage protection	TS40
PC02	Compressor top (or IPM) temp. protection	TS41
PC04	Inverter compressor drive error	TS42
PC03	Pressure protection(low or high pressure)(for some models)	TS43
PC0L	Low ambient temperature protection(for some models)	TS46
----	IDUs mode conflict(Multi-zone)	TS46

For other errors:

The display board may show a garbled code or a code undefined by the service manual. Ensure that this code is not a temperature reading.

Troubleshooting:

Test the unit using the remote control. If the unit does not respond to the remote, the indoor PCB requires replacement. If the unit responds, the display board requires replacement.

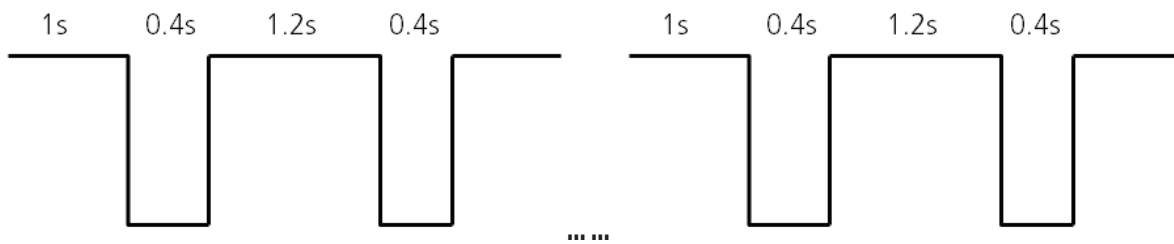
88 flash frequency:

2.2 Error Display (Outdoor Unit with auxiliary board)

Display	Malfunction or Protection	Solution
dF	Defrost	Normal Display, not error code
FC	Forced cooling	
ECS1	ODU EEPROM parameter error	TS24
EL01	IDU & ODU communication error	TS25
PC40	Communication error between outdoor main chip and compressor driven chip	TS49
PC08	ODU overcurrent protection	TS36
PC10	ODU low AC voltage protection	TS40
PC11	ODU main control board DC bus high voltage protection	TS40
PC12	ODU main control board DC bus low voltage protection/341 MCE error	TS40
PC00	ODU IPM module protection	TS39
PC0F	PFC module protection	TS48
EC71	Over current failure of ODU DC fan motor	TS30
EC72	Lack phase failure of ODU DC fan motor	TS51
EC07	ODU fan speed out of control	TS30
PC42	Compressor start failure of outdoor unit	TS36
PC43	ODU compressor lack phase protection	TS52
PC44	ODU zero speed protection	TS36
PC45	ODU IR chip drive failure	TS53
PC46	Compressor speed has been out of control	TS36
PC49	Compressor overcurrent failure	TS36
PC30	System high pressure protection	TS43
PC31	System low pressure protection	TS43
PC0R	High temperature protection of condenser	TS47
PC06	Discharge temperature protection of compressor	TS50
LC06	High temperature protection of Inverter module (IPM)	TS41
PC02	Compressor top (or IPM) temp. protection	TS41
PH90	High temperature protection of evaporator	--
PH91	Low temperature protection of evaporator	--
ECS2	ODU coil temp. sensor (T3) error	TS33
ECS3	ODU ambient temp. sensor (T4) error	TS33
ECS4	COMP. discharge temp. sensor (TP) error	TS33
ECS0	Open or short circuit of outdoor unit temperature sensor(T3,T4.TP)	TS33
PC0L	Low ambient temperature protection(for some models)	TS46

3. Outdoor Unit Point Check Function

- A check switch is included on the auxiliary board.
- Push SW1 to check the unit's status while running. The digital display shows the following codes each time the SW1 is pushed.

Number of Presses	Display	Remark		
00	Normal display	Display running frequency, running state or malfunction code		
01	Indoor unit capacity demand code	S communication models display "--"		
02	Amendatory capacity demand code			
03	The frequency after the capacity requirement transfer			
04	The frequency after the frequency limit			
05	The frequency of sending to 341 chip			
06	Indoor unit evaporator temperature	If the temp. is lower than -9 degree, the digital display tube will show "-9".If the temp. is higher than 70 degree, the digital display tube will show "70".		
07	Condenser pipe temp.(T3)			
08	Outdoor ambient temp.(T4)			
09	Compressor discharge temp.(TP)	The display value is between 0~199°C. If the temp. is lower than 0°C, the digital display tube will show "0".If the temp. is higher than 99°C,light the decimal point of the high digit tube. (For example, the digital display tube show "0.5",so 0.5 multiplied by 10 to become 5, then added to 100 to become 105°C.)		
10	AD value of current	The display value is hex number.		
11	AD value of voltage	For example, the digital display tube shows "Cd", so $C*161+d*160=12*16+13=205$, it means AD value is 205.		
12	Indoor unit running mode code	Standby:0,Cooling:1, Heating:2, Fan only: 3, Drying:4, Forced cooling:6, Defrosting:7		
13	Outdoor unit running mode code	Standby:0,Cooling:1, Heating:2, Fan only: 3, Drying:4, Forced cooling:6, Defrosting:7		
14	EXV open angle	Actual data/4. If the value is higher than 99, light the decimal point of the high digit tube. For example, the digital display tube show "2.0",so 2.0 multiplied by 10 to become 20, then added to 100 to become 120,it means the EXV open angle is $120 \times 4 = 480p$.)		
15	Frequency limit symbol	Bit7	Frequency limit caused by IGBT radiator	The display value is hex number. For example, the digital display tube show 2A, the corresponding binary is 101010, so Bit5=1, Bit3=1, and Bit1=1 It means frequency limit caused by T2, T3 and current.
		Bit6	Frequency limit caused by PFC	
		Bit5	Frequency limit caused by high temperature of T2.	
		Bit4	Frequency limit caused by low temperature of T2.	
		Bit3	Frequency limit caused by T3.	
		Bit2	Frequency limit caused by TP.	
		Bit1	Frequency limit caused by current	
Bit0	Frequency limit caused by voltage			
16	DC fan motor speed	0:off 1:Turbo 2:High 3:Medium 4:Low 5: Breeze 6: Super breeze 7:other		
17	IGBT radiator temp.	The display value is between 0~130 degree. If the temp. is lower than 0°C, the digital display tube will show "0".If the temp. is higher than 99 degree, light the decimal point of the high digit tube. (For example, the digital display tube show "0.5",so 0.5 multiplied by 10 to become 5, then added to 100 to become 105°C.)		
18	Indoor unit number	The indoor unit can communicate with outdoor unit well.		
19	Evaporator pipe temp. T2 of 1# indoor unit	S communication models display "--"		
20	Evaporator pipe temp. T2 of 2# indoor unit			
21	Evaporator pipe temp. T2 of 3# indoor unit			
22	1# Indoor unit capacity demand code			
23	2# Indoor unit capacity demand code			
24	3# Indoor unit capacity demand code			
25	Room temp. T1 of 1# indoor unit			
26	Room temp. T1 of 2# indoor unit			
27	Average room temp. T1	If the temp. is lower than 0 degree, the digital display tube will show "0".If the temp. is higher than 70 degree, the digital display tube will show "70". If the indoor unit is not connected, the digital display tube will show: "--"		
28	Reason of stop			
29	Evaporator pipe temp. T2B of 1# indoor unit	S communication models display "--"		
30	Evaporator pipe temp. T2B of 2# indoor unit			

4. Complain Record Form

Complain Record Form

Request No.:

Date:

Installation Date:

Service Date:

Customer Information			
Name		Telephone No.	
Home Address			
Email			
Product Information			
Indoor Unit Model		Outdoor Unit Model	
Serial No. of indoor unit			
Serial No. of outdoor unit			
Working Mode	<input type="checkbox"/> Cooling <input type="checkbox"/> Heating <input type="checkbox"/> Fan only <input type="checkbox"/> Dry		
Setting temperature	_____°C / °F	Fan speed	<input type="checkbox"/> Turbo <input type="checkbox"/> High <input type="checkbox"/> Medium <input type="checkbox"/> Low <input type="checkbox"/> Auto
Temperature of air inlet	_____°C / °F	Temperature of air outlet	_____°C / °F
Installation / Condition Information			
Indoor temperature	_____°C / °F	Indoor humidity	_____ %RH
Outdoor temperature	_____°C / °F	Outdoor humidity	_____ %RH
Length of Connecting pipe		Pipe diameter	Gas pipe: Liquid pipe:
Length of Wiring		wire diameter	
System Running Pressure	_____MPa or _____Bar or _____PSI		
Room size (L*W*H)			
Photo of Installation of Indoor unit (Photo #1)		Photo of Installation of Outdoor unit (Photo #2)	
Failure Description			
Error Code of Indoor unit		Code of Outdoor PCB	
Unit does not start			
Remote control does not work			
Indoor display shows nothing			
No cooling or heating at all			
Less cooling or heating			
Unit starts but stops shortly			
High noise			
High vibration			

Parameter Checking information by Remote controller			
Displaying code	Displaying code meaning	Display value	Display value meaning
T1	Room temperature		
T2	Indoor coil temperature		
T3	Outdoor coil temperature		
T4	Ambient temperature		
TP	Discharge temperature		
FT	Targeted Frequency		
Fr	Actual Frequency		
dL	Compressor current		
Uo	Outdoor AC voltage		
Sn	Indoor capacity test	/	N/A
--	Reserve	/	N/A
Pr	Outdoor fan speed		
Lr	EXV opening steps		
ir	Indoor fan speed		
HU	Indoor humidity		
TT	Adjusted setting temperature		
DT	Reserve	/	N/A
iF	Reserve	/	N/A
nA	Reserve	/	N/A
oT	GA algorithm frequency		

Approval from Manufacturer	
<input type="checkbox"/> Approved	
<input type="checkbox"/> More Proof needed	
<input type="checkbox"/> Rejected	

5. Information Inquiry&Setting

- To enter engineer mode, in power-on or standby mode, and in non-locked state, press the key combination "ON/OFF + Air Speed" for 7s:
- After entering the engineer mode, the remote control will display icons of "Auto, Cool, Dry, Heat", and the Battery icon; at the same time, it will also display the numeric code of the current engineer mode (for the initial engineer mode, the numeric code displayed is 0), and all other icons are inactive.
- In engineer mode, the value of the current numeric code can be adjusted circularly through the Up/Down key, with the setting range of 0 to 30. Each time the current numeric code is adjusted, the special code of the engineer mode will be transmitted with a delay of 0.6s. The code can also be transmitted by pressing "OK", and the special code of the engineer mode sent contains information of the currently displayed numeric code (if the numeric code is 0, the code to enter the engineer mode will be transmitted).
- In engineer mode, other keys or operations are invalid except for the On/Off key, the Up/Down key, the OK key or executing the operation to exit the engineer mode.

Code	Query Content	Advanced Function Setting
0	Error code	press "On/Off" for 2s to enter the Capacity, the code displayed is "Ch", press "OK" to send the Query Capacity code; press the Up/Down key to select 1 to 100K
1	T1 temperature	press "On/Off" for 2s to enter the Power Down Memory Selector, the code displayed is "Ch", press "OK" to send the Query Power Down Memory Selector code; press the Up/Down key to select 1 or 0 and press "OK" to confirm, 1 indicates that the power down memory exists, and 0 indicates that no power down memory exists; and press "On/Off" for 2s to exit. (Set within 1 minute after power on)
2	T2 temperature	press "On/Off" for 2s to enter the Internal Fan Control Selector after the pre-set temperature is reaches, the code displayed is "Ch", press "OK" to send the Query Internal Fan Control Selector code; press the Up/Down key to select 1 to 13: 1 - Stop the fan, 2 - Min. fan speed, 3 - Set the air speed, 4 - Termal stop for 4min running for 1min, 5 - Termal stop for 8min running for 1min, 6 - Termal stop for 16min running for 1min, 7 - Termal stop for 24min running for 1min, 8 - Termal stop for 48min running for 1min, 9 - Termal stop for 15min running for 2.5min, 10 - Termal stop for 30min running for 2.5min, 11 - Termal stop for 60min running for 2.5min, 12- Set fan speed(but stop the fan when the set fan speed is auto fan) and 13- Breeze fan(but stop the fan when the set fan speed is auto fan) press "OK" to confirm, and press "On/Off" for 2s to exit.(Item 5~13 are valid for some models)(Set within 1 minute after power on)
3	T3 temperature	press "On/Off" for 2s to enter the Mode Selector, press the Up/Down key to select CH (cool and heat, Auto + Cool + Dry + Heat + Fan), HH (Heat only, Heat only + Fan), CC(Cool only, Auto + Cool + Dry + Fa) or nU (Cool and Heat without Auto, Cool + Dry + Heat + Fan), press "OK" to confirm, and the mode selected can be memorized when the remote control is powered down and powered on; and press "On/Off" for 2s to exit. When the remote control does not burn any parameters, the mode setting will not be memorized.(CC or nU is valid for some models)(Set within 1 minute after power on)
4	T4 temperature	press the "On/Off" for 2s to enter the Min. Set Temperature Selector, press the Up/Down key to select "16°C~24°C", press "OK" to confirm, and the Min. Set Temperature can be memorized when the remote control is powered on and power lost; and press "On/Off" for 2s to exit. When the remote control does not burn any parameters, the min. set temperature will not be memorized.(Set within 1 minute after power on)

5	TP temperature	press "On/Off" for 2s to enter the Max. Set Temperature Selector, press the Up/Down key to select "25°C~30°C", press "OK" to confirm, and the Max. Set Temperature can be memorized when the remote control is powered on and power lost; and press "On/Off" for 2s to exit. When the remote control does not burn any parameters, the max. set temperature will not be memorized.(Set within 1 minute after power on)
6	Compressor Target Frequency FT	press "On/Off" for 2s to enter the Multi-split Cooling and Heating Preference Selector, the code displayed is "Ch", press "OK" to send the Query Multi-split Cooling and Heating Preference Selector code; press the Up/Down key to select H (heating preferred), C (cooling preferred) or A (master settings), press "OK" to confirm; and press "On/Off" for 2s to exit.(Set within 1 minute after power on)(Only multi models are effective)
7	Compressor Running Frequency Fr	/
8		/
9	Current AC Voltage Uo	/
10		/
11		press "On/Off" for 2S to enter the Min. Desired Cooling Frequency Selector, the code displayed is Ch, press "OK" to send the Query Min. Desired Cooling Frequency Selector code; press the Up/Down key to select the minimum cooling frequency desired and press "OK" to confirm; press "On/Off" for 2s to exit.(Range:10-50Hz,--; "--" cancels the Settings)(for some models) (Set within 1 minute after power on)
12	Set Speed Pr of the outdoor fan	press "On/Off" for 2s to enter the Min. Desired Heating Frequency Selector, the code displayed is "Ch", press "OK" to send the Query Min. Desired Heating Frequency Selector code; press the Up/Down key to select the min. desired heating frequency value, press "OK" to confirm; and press the "On/Off" for 2s to exit.(Range:10-50Hz,--; "--" cancels the Settings) (for some models)(Set within 1 minute after power on)
13	Opening Lr of EEV	press "On/Off" for 2s to enter the Max. Running Frequency Selector of the restricted area 6 in the cooling mode T4, the code displayed is "Ch", press "OK" to send the Query Max. Running Frequency Selector code of the restricted area 6 in the cooling mode T4; press the Up/Down key to select the limit, then press "OK" to confirm; and press "On/Off" for 2s to exit. (Range:20-150Hz,--; "--" cancels the Settings)(for some models)
14	Actual Running Speed ir of the indoor fan	press "On/Off" for 2s to enter the Resonance Point Frequency Selector, the code displayed is "Ch", press "OK" to send the Resonance Point Frequency Selector code; press the Up/Down key to select the outdoor forced running frequency("10-250Hz"), then press "OK" to confirm; and press "On/Off" for 2s to exit.(Range:10-250Hz,--; "--" cancels the Settings)(for some models)
15	Indoor Humidity Hu	press "On/Off" for 2s to enter the Outdoor Forced Running Frequency Selector, the code displayed is "Ch", press "OK" to send the Query Outdoor Forced Running Frequency Selector code; press the Up/Down key to select the outdoor forced running frequency("10-250Hz"), then press "OK" to confirm; and press "On/Off" for 2s to exit.(Range:10-250Hz,--; "--" cancels the Settings)(for some models)
16	Set Temperature TT after compensation	press "On/Off" for 2s to enter One-Key Recovery, the code displayed is "rS", then press "OK" to send the One-Key Recovery code, the mode selector of the remote control will recover to "Cooling and heating", the min. temperature recovers to 16°C, and the max. temperature recovers to 30°C; and press "On/Off" for 2s to exit.(for some models)

17	/	/
18	WiFi signal strength	press "On/Off" for 2s to enter Model Selection the code displayed is "Ch", then press "OK" to send the Model Selection code, press the Up/Down key to select,such as 23,26,32,35,51,72,120 etc; and press "On/Off" for 2s to exit.
19	Dc bus voltage AD value	press "On/Off" for 2s to enter the Cooling Frequency Threshold Settings; press the Up/Down key to select the cooling frequency threshold, press "OK" to confirm; and press the "On/Off" for 2s to exit. (Range:40,41.....83,84,--; "--" cancels the Settings)(Set within 1 minute after power on)
20	Indoor Target Frequency of T	press "ON/OFF" for 2s to enter the Heating Frequency Threshold Settings; press the Up/Down key to select the heating frequency threshold, press "OK" to confirm; and press "On/Off" for 2s to exit.(Range:40,41.....83,84,--; "--" cancels the Settings) (Set within 1 minute after power on)
21	Reserve	press "On/Off" for 2s to enter the Cooling Temperature Compensation Value Settings, the code displayed is "Ch", then press "OK" to send the Query Cooling Temperature Compensation Value code; press the Up/Down key to select the cooling temperature compensation value, then press "OK"; and press "On/Off" for 2s to exit.(Range:-3.0,-2.5,-2.0...2.0,2.5,3.0,3.5,--; "--" cancels the Settings)
22		press "On/Off" for 2s to enter the Heating Temperature Compensation Value Settings, the code displayed is "Ch", press "OK" to send the Query Heating Temperature Compensation Value code; press the Up/Down key to select the heating temperature compensation value, then press "OK"; and press "On/Off" for 2s to exit.(Range:-6.5,-6,...1.0,1.5,2.0...6.0,6.5,7.0,7.5,--; "--" cancels the Settings)
23		press "On/Off" for 2s to enter the Max. Cooling Air Speed Settings, the code displayed is "Ch", press "OK" to send the Query Max. Cooling Air Speed code; press the Up/Down key to select the max. cooling air speed, then press "OK"; and press "On/Off" for 2s to exit.(Range: -41,-40,-39...17,18,19,20,--; "--" cancels the Settings)
24		press "On/Off" for 2S to enter the Min. Cooling Air Speed Settings, the code displayed is "Ch", press "OK" to send the Query Min. Cooling Air Speed code; press the Up/Down key to select the minimum cooling air speed and press "OK" to confirm; press "On/Off" for 2s to exit.(Range: -41,-40,-39...17,18,19,20,--; "--" cancels the Settings)
25		press "On/Off" for 2s to enter the Max. Heating Air Speed Settings, the code displayed is "Ch", press "OK" to send the Query Max. Heating Air Speed code; press the Up/Down key to select the maximum heating air speed and press "OK" to confirm; press "On/Off" for 2s to exit.(Range: -41,-40,-39...17,18,19,20,--; "--" cancels the Settings)
26		press "On/Off" for 2s to enter the Min. Heating Air Speed Settings, the code displayed is "Ch", press "OK" to send the Query Min. Heating Air Speed code; press the Up/Down key to select the minimum heating air speed and press "OK" to confirm; press "On/Off" for 2s to exit.(Range: -41,-40,-39...17,18,19,20,--; "--" cancels the Settings)
27		/
28		press "On/Off" for 2s to enter the The Temperature of Stop Fan, the code displayed is "Ch", press "OK" to send the The Temperature of Stop Fan code; press the Up/Down key to select 16,17,18...28 and press "OK" to confirm; press "On/Off" for 2s to exit.
29		
30		

- In Channel 1~30 settings of the engineer mode, long press the On/off key to return the previous engineer mode.
- When the setting is successful, "CS" will be displayed;When the setting fails, "CF "will be displayed.

Exit of engineer mode:

1)In engineer mode, press the key combination of "On/Off + Air speed" for 2s;

2)The engineer mode will be exited if there are no valid key operations for continuous 60s.

Error code of engineer mode

Display	Error Information
•R	No fault or protection
E400	IDU EEPROM malfunction
E40A	Indoor EEPROM parameter error
E401	IDU & ODU communication error
E4bA	Communication error between indoor unit and indoor external fan module
E430	Parameters error of indoor external fan
E435	Phase failure of indoor external fan
E436	Indoor external fan current sampling bias fault
E437	Indoor external fan zero speed failure
E438	Indoor external fan stall failure
E439	Out of step failure of indoor external fan
E43A	Low voltage protection of indoor external fan DC bus
E43b	Indoor external fan DC bus voltage is too high fault
E43E	Indoor external fan overcurrent fault
E43F	Indoor external fan module protection/hardware overcurrent protection
E403	IDU fan speed out of control
ECS1	ODU EEPROM parameter error
ECS2	ODU coil temp. sensor (T3) error
ECS3	ODU ambient temp. sensor (T4) error
ECS4	COMP. discharge temp. sensor (TP) error
ECS5	ODU IPM module temp.sensor(TH) error
E40d	Outdoor unit malfunction
E460	IDU room temp. sensor (T1) error
E461	Evaporator coil temperature sensor T2 is in open circuit or short circuit
E471	Outdoor external fan overcurrent fault
E475	Outdoor external fan module protection/hardware overcurrent protection
E472	Outdoor external fan phase failure
E474	Outdoor external fan current sampling bias fault
E473	Zero speed failure of outdoor unit DC fan
E407	ODU fan speed out of control(
E40C	System lacks refrigerant

PC00	ODU IPM module protection
PC10	ODU low AC voltage protection
PC11	ODU main control board DC bus high voltage protection
PC12	ODU main control board DC bus low voltage protection/341 MCE error
PC02	Compressor top (or IPM) temp. protection
PC40	Communication error between outdoor main chip and compressor driven chip
PC41	Compressor current sampling circuit failure
PC42	Compressor start failure of outdoor unit
PC43	ODU compressor lack phase protection
PC44	ODU zero speed protection
PC45	ODU IR chip drive failure
PC46	Compressor speed has been out of control
PC49	Compressor overcurrent failure
PC06	Discharge temperature protection of compressor
PC08	ODU Current protection
PH09	Anti-cold air in heating mode
PC0F	PFC module protection
PC30	System overpressure protection
PC31	System pressure is too low protection
PC03	Pressure protection(low or high pressure)
PC0L	Outdoor low temp. protection
PH90	High temperature protection of evaporator
PH91	Low temperature protection of evaporator
PC0R	High temperature protection of condenser
PH0C	Indoor unit humidity sensor malfunction
LH00	Evaporator temp. freq.limited(L0)
LH30	Indoor external fan current freq. limited
LH31	Indoor external fan voltage freq. limited
LC01	Condenser coil temp. (T3) freq. limited
LC02	ODU exhaust temp. (TP) freq. limited
LC05	Voltage freq. limited
LC03	Current freq. limited
LC06	IPM module temp. freq. limited
LC30	High pressure freq. limited
LC31	Low pressure freq. limited
LH07	Remote control frequency limitation in effect
--	IDUs mode conflict(Multi-zone)

6. Error Diagnosis and Troubleshooting Without Error Code



WARNING

Be sure to turn off unit before any maintenance to prevent damage or injury.

6.1 Remote maintenance

SUGGESTION: When troubles occur, please check the following points with customers before field maintenance.

No.	Problem	Solution
1	Unit will not start	TS17 - TS18
2	The power switch is on but fans will not start	TS17 - TS18
3	The temperature on the display board cannot be set	TS17 - TS18
4	Unit is on but the wind is not cold(hot)	TS17 - TS18
5	Unit runs, but shortly stops	TS17 - TS18
6	The unit starts up and stops frequently	TS17 - TS18
7	Unit runs continuously but insufficient cooling(heating)	TS17 - TS18
8	Cool can not change to heat	TS17 - TS18
9	Unit is noisy	TS17 - TS18

6.2 Field maintenance

	Problem	Solution
1	Unit will not start	TS19 - TS20
2	Compressor will not start but fans run	TS19 - TS20
3	Compressor and condenser (outdoor) fan will not start	TS19 - TS20
4	Evaporator (indoor) fan will not start	TS19 - TS20
5	Condenser (Outdoor) fan will not start	TS19 - TS20
6	Unit runs, but shortly stops	TS19 - TS20
7	Compressor short-cycles due to overload	TS19 - TS20
8	High discharge pressure	TS19 - TS20
9	Low discharge pressure	TS19 - TS20
10	High suction pressure	TS19 - TS20
11	Low suction pressure	TS19 - TS20
12	Unit runs continuously but insufficient cooling	TS19 - TS20
13	Too cool	TS19 - TS20
14	Compressor is noisy	TS19 - TS20
15	Horizontal louver can not revolve	TS19 - TS20

1.Remote Maintenance	Electrical Circuit				Refrigerant Circuit									
Possible causes of trouble	Power failure	The main power tripped	Loose connections	Faulty transformer	The voltage too high or too low	The remote control is powered off	Broken the remote control	Dirty air filter	Dirty condenser fins	The setting temperature is higher/lower than the room's(cooling/heating)	The ambient temperature is too high/low when the mode is cooling/heating	Fan mode	SILENCE function is activated(Optional function)	Frosting and defrosting frequently
	Unit will not start	☆	☆	☆	☆									
	The power switch is on but fans will not start			☆	☆	☆								
	The temperture on the playboard cannot be setted						☆	☆						
	Unit is on but the wind is not cold(hot)									☆	☆	☆		
	Unit runs, but shortly stops					☆				☆	☆			
	The unit startup and stop frequently					☆						☆		☆
	Unit runs continuously but insufficient cooling(heating)								☆	☆	☆	☆		☆
	Cool can not change to heat													
	Unit is noisy													
Test method / remedy	Test voltage													
	Close the power switch													
	inspect connections - tighten													
	Change the transformer													
	Test voltage													
	Replace the battery of the remote control													
	Replace the remote control													
	Clean or replace													
	Clean													
	Adjust the setting temperature													
Turn on the AC later														
Adjust to cool mode														
Turn off the SILENCE function														
Turn on the AC later														

1.Remote Maintenance	Others					
Possible causes of trouble	Heavy load condition	Loosen hold down bolts and / or screws	Bad airproof	The air inlet or outlet of either unit is blocked	Interference from cell phone towers and remote boosters	Shipping plates remain attached
	Unit will not start					
	The power switch is on but fans will not start				☆	
	The temperature on the display board cannot be set					
	Unit is on but the wind is not cold(hot)					
	Unit runs, but shortly stops					
The unit starts up and stops frequently				☆		
Unit runs continuously but insufficient cooling(heating)	☆		☆	☆		
Cool can not change to heat						
Unit is noisy		☆			☆	
Test method / remedy	Check heat load	Tighten bolts or screws	Close all the windows and doors	Remove the obstacles	Reconnect the power or press ON/OFF button on remote control to restart operation	Remove them

2.Field Maintenance	Refrigerant Circuit													Others										
Possible causes of trouble	Compressor stuck	Shortage of refrigerant	Restricted liquid line	Dirty air filter	Dirty evaporator coil	Insufficient air through evaporator coil	Overcharge of refrigerant	Dirty or partially blocked condenser	Air or incompressible gas in refrigerant cycle	Short cycling of condensing air	High temperature condensing medium	Insufficient condensing medium	Broken compressor internal parts	Inefficient compressor	Expansion valve obstructed	Expansion valve or capillary tube closed completely	Leaking power element on expansion valve	Poor installation of feeler bulb	Heavy load condition	Loosen hold down bolts and / or screws	Shipping plates remain attached	Poor choices of capacity	Contact of piping with other piping or external plate	
Unit will not start																								
Compressor will not start but fans run	☆																							
Compressor and condenser (outdoor) fan will not start																								
Evaporator (indoor) fan will not start																								
Condenser (Outdoor) fan will not start																								
Unit runs, but shortly stops	☆	☆					☆	☆								☆	☆							
Compressor short-cycles due to overload	☆						☆	☆																
High discharge pressure							☆	☆	☆	☆	☆	☆												
Low discharge pressure	☆													☆										
High suction pressure							☆							☆				☆	☆					
Low suction pressure	☆	☆	☆	☆	☆										☆	☆	☆							
Unit runs continuously but insufficient cooling	☆	☆	☆	☆	☆			☆	☆	☆				☆					☆			☆		
Too cool																								
Compressor is noisy							☆						☆							☆	☆		☆	
Horizontal louver can not revolve																								
Test method / remedy	Replace the compressor	Leak test	Replace restricted part	Clean or replace	Clean coil	Check fan	Change charged refrigerant volume	Clean condenser or remove obstacle	Purge, evacuate and recharge	Remove obstruction to air flow	Remove obstruction in air or water flow	Remove obstruction in air or water flow	Replace compressor	Test compressor efficiency	Replace valve	Replace valve	Replace valve	Fix feeler bulb	Check heat load	Tighten bolts or screws	Remove them	Choose AC of larger capacity or add the number of AC	Rectify piping so as not to contact each other or with external plate	

2.Field Maintenance	Electrical Circuit														
Possible causes of trouble	Power failure	Blown fuse or varistor	Loose connections	Shorted or broken wires	Safety device opens	Faulty thermostat / room temperature sensor	Wrong setting place of temperature sensor	Faulty transformer	Shorted or open capacitor	Faulty magnetic contactor for compressor	Faulty magnetic contactor for fan	Low voltage	Faulty stepping motor	Shorted or grounded compressor	Shorted or grounded fan motor
Unit will not start	☆	☆	☆	☆	☆			☆							
Compressor will not start but fans run				☆		☆			☆	☆				☆	
Compressor and condenser (outdoor) fan will not start				☆		☆			☆						
Evaporator (indoor) fan will not start				☆				☆		☆					☆
Condenser (Outdoor) fan will not start				☆		☆		☆	☆	☆					☆
Unit runs, but shortly stops									☆		☆				
Compressor short-cycles due to overload									☆		☆				
High discharge pressure															
Low discharge pressure															
High suction pressure															
Low suction pressure															
Unit runs continuously but insufficient cooling															
Too cool						☆	☆								
Compressor is noisy															
Horizontal louver can not revolve			☆	☆								☆			
Test method / remedy	Test voltage	Inspect fuse type & size	Inspect connections - tighten	Test circuits with tester	Test continuity of safety device	Test continuity of thermostat / sensor & wiring	Place the temperature sensor at the central of the air inlet grille	Check control circuit with tester	Check capacitor with tester	Test continuity of coil & contacts	Test continuity of coil & contacts	Test voltage	Replace the stepping motor	Check resistance with multimeter	Check resistance with multimeter

7. Quick Maintenance by Error Code

If you do not have the time to test which specific parts are faulty, you can directly change the required parts according to the error code. You can find the parts to replace by error code in the following table.

Part requiring replacement	Error Code									
	EH00/ EH0R	EL01	EH02	EH03	EH60	EH61	EH0b	EL0C	ECS6	FHCC
Indoor PCB	✓	✓	✓	✓	✓	✓	✓	✓	x	✓
Outdoor PCB	x	✓	x	x	x	x	x	x	✓	x
Display board	x	x	x	x	x	x	✓	x	x	x
Indoor fan motor	x	x	x	✓	x	x	x	x	x	x
T1 sensor	x	x	x	x	✓	x	x	x	x	x
T2 Sensor	x	x	x	x	x	✓	x	✓	x	x
T2B Sensor	x	x	x	x	x	x	x	x	✓	x
Refrigerant sensor	x	x	x	x	x	x	x	x	x	✓
Reactor	x	✓	x	x	x	x	x	x	x	x
Compressor	x	x	x	x	x	x	x	x	x	✓
Additional refrigerant	x	x	x	x	x	x	x	✓	x	x

Part requiring replacement	ECS3	ECS2	ECS4	ECS1	EC07	PC00	PC01	PC02	PC03	PC04
Outdoor PCB	✓	✓	✓	✓	✓	✓	✓	✓	✓	✓
Indoor fan motor	x	x	x	x	x	x	x	x	x	x
Outdoor fan motor	x	x	x	x	✓	✓	x	✓	x	✓
T3 Sensor	x	✓	x	x	x	x	x	x	x	x
T4 Sensor	✓	x	x	x	x	x	x	x	x	x
TP Sensor	x	x	✓	x	x	x	x	x	x	x
Reactor	x	x	x	x	x	x	✓	x	x	x
Compressor	x	x	x	x	x	✓	x	x	x	✓
IPM module board	x	x	x	x	x	✓	✓	✓	x	✓
High pressure protector	x	x	x	x	x	x	x	✓	x	x
Low pressure protector	x	x	x	x	x	x	x	x	✓	x
Additional refrigerant	x	x	x	x	x	x	x	x	✓	x

Part requiring replacement	PC06	PC08/44/49	PC0R	PC0F	PC40
Outdoor PCB	✓	✓	✓	✓	✓
Outdoor fan motor	x	✓	✓	x	x
T3 Sensor	x	x	✓	x	x
TP Sensor	✓	x	x	x	x
Pressure sensor	x	x	x	x	x
Reactor	x	✓	x	✓	x
Compressor	x	x	x	x	x
IPM module board	x	✓	x	x	✓
High pressure valve assy	✓	x	x	x	x
High pressure protector	x	x	x	x	x
Low pressure protector	x	x	x	x	x
Additional refrigerant	✓	x	✓	x	x
Electric control box	x	x	x	x	✓

Part requiring replacement	PC41	PC43	PC10/11/12	PC30	PC31
Outdoor PCB	✓	✓	✓	✓	✓
Outdoor fan motor	x	x	x	✓	x
T3 Sensor	x	x	x	x	x
TP Sensor	x	x	x	x	x
Pressure sensor	x	x	x	x	x
Reactor	x	x	✓	x	x
Compressor	x	✓	x	x	x
IPM module board	x	x	✓	x	x
High pressure valve assy	x	x	x	x	x
High pressure protector	x	x	x	✓	x
Low pressure protector	x	x	x	x	✓
Additional refrigerant	x	x	x	x	✓

8. Troubleshooting by Error Code

8.1 EH00/ EH0A(IDU EEPROM malfunction or IDU EEPROM parameter error) diagnosis and solution

Description: Indoor PCB main chip does not receive feedback from EEPROM chip.

Recommended parts to prepare:

- Indoor PCB

Troubleshooting and repair:

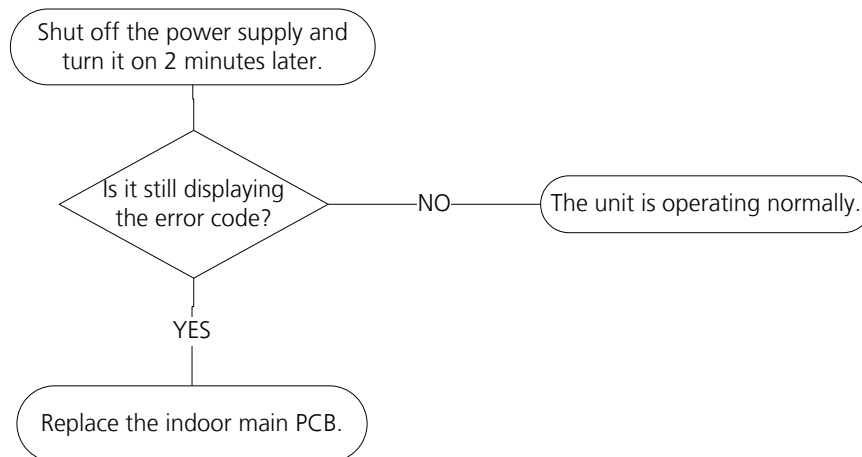

Remarks:

EEPROM: A read-only memory whose contents can be erased and reprogrammed using a pulsed voltage.

The location of the EEPROM chip on the indoor PCB is shown in the following image:

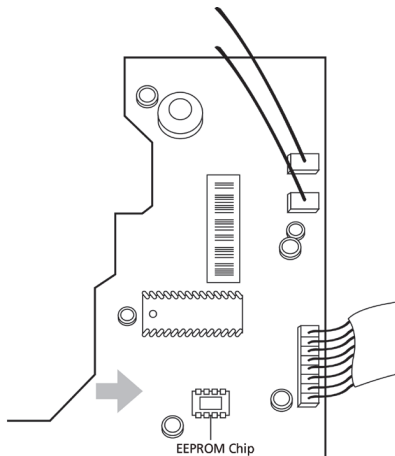

Note: This pictures are only for reference, actual appearance may vary.

8.2 EC51(ODU EEPROM parameter error) diagnosis and solution

Description: Outdoor PCB main chip does not receive feedback from EEPROM chip.

Recommended parts to prepare:

- Outdoor PCB

Troubleshooting and repair:

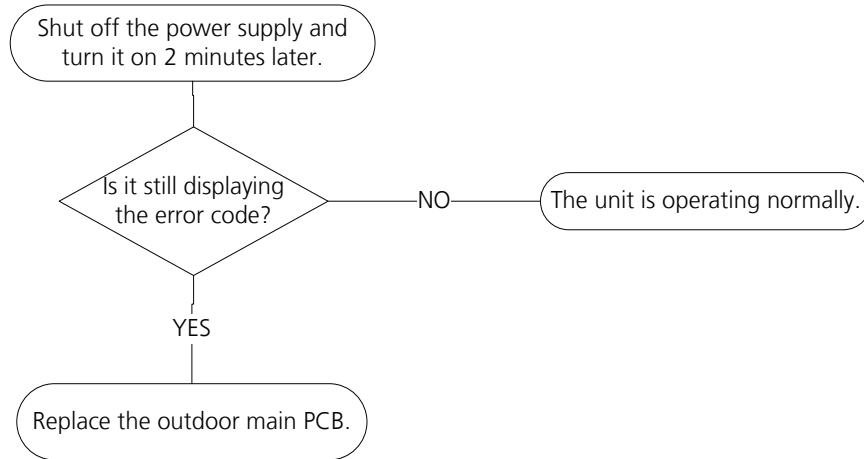

Remarks:

EEPROM: A read-only memory whose contents can be erased and reprogrammed using a pulsed voltage.

The location of the EEPROM chip on the outdoor PCB is shown in the following image:

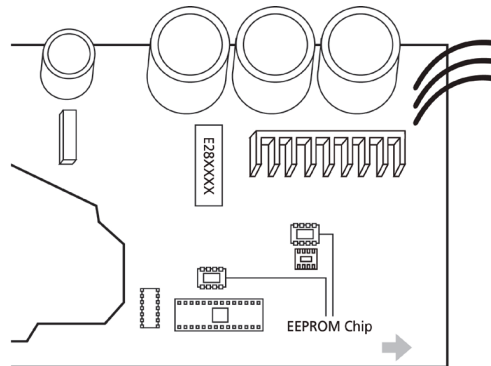

This pictures are only for reference, actual appearance may vary.

8.3 EL01(IDU & ODU communication error) diagnosis and solution

Description: Indoor unit can not communicate with outdoor unit

Recommended parts to prepare:

- Indoor PCB
- Outdoor PCB
- Short-circuited component

Troubleshooting and repair:

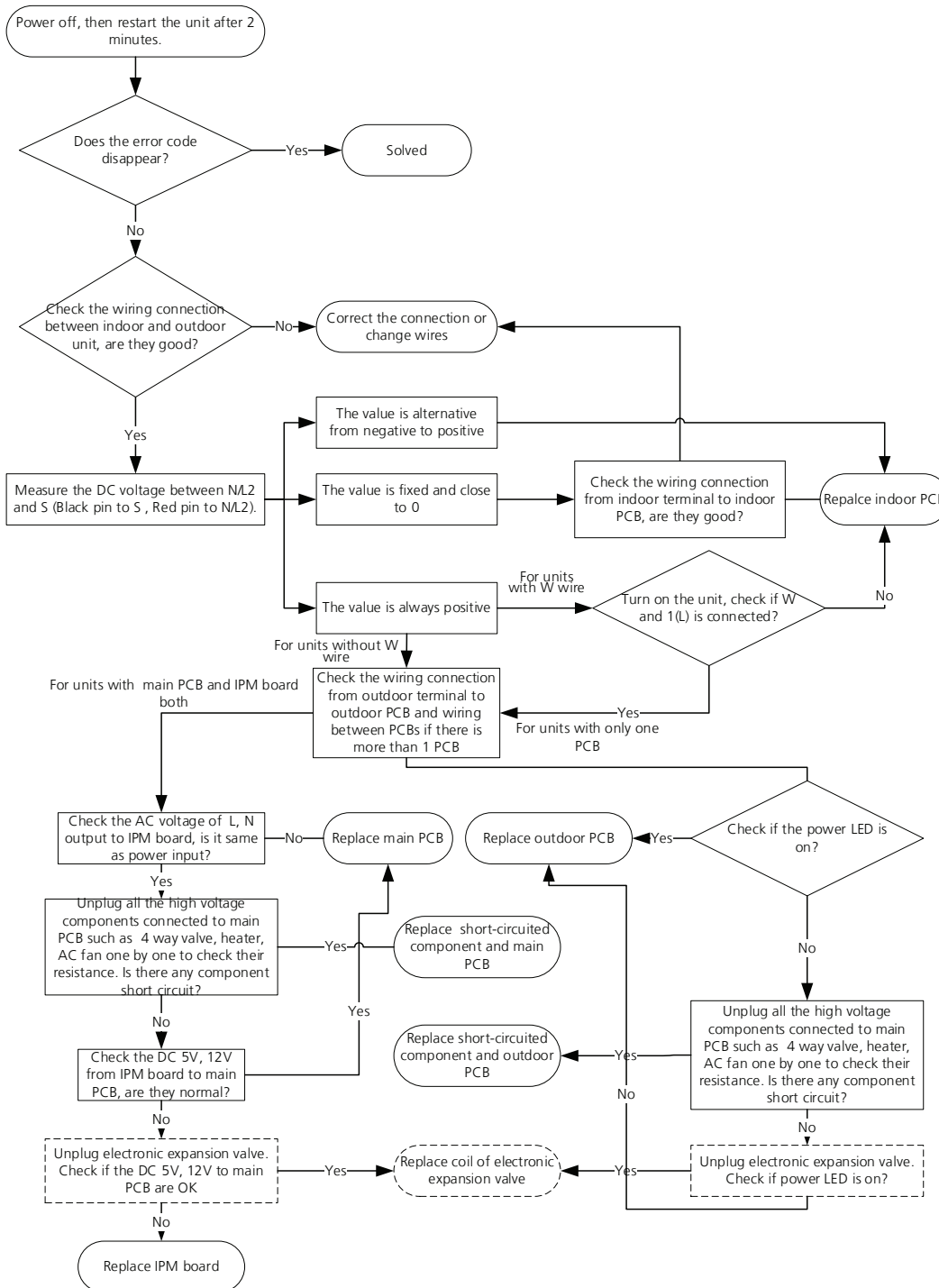

Remarks:

- Use a multimeter to test the DC voltage between 2 port(or S or L2 port) and 3 port(or N or S port) of outdoor unit. The red pin of multimeter connects with 2 port(or S or L2 port) while the black pin is for 3 port(or N or S port) .
- When AC is normal running, the voltage will move alternately between -25V to 25V.
- If the outdoor unit has malfunction, the voltage will move alternately with positive value.
- While if the indoor unit has malfunction, the voltage will be a certain value.

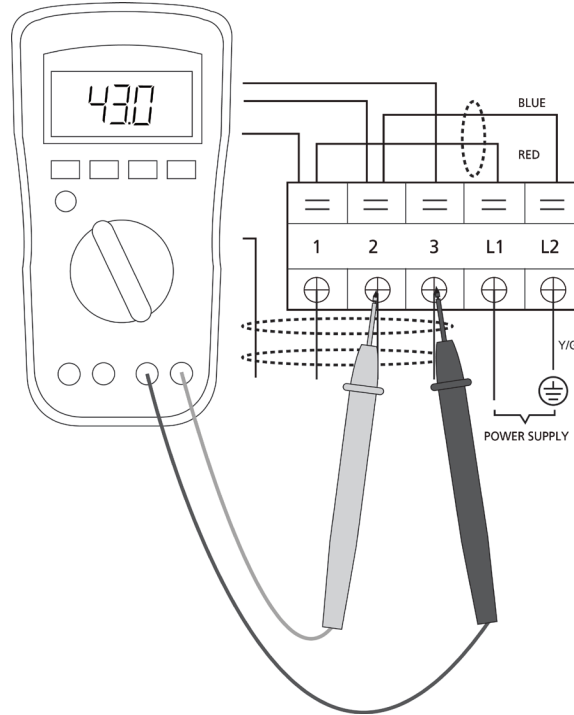

**S and N
or
L2 and S
or
2 and 3**

- Use a multimeter to test the resistance of the reactor which does not connect with capacitor.
- The normal value should be around zero ohm. Otherwise, the reactor must have malfunction.

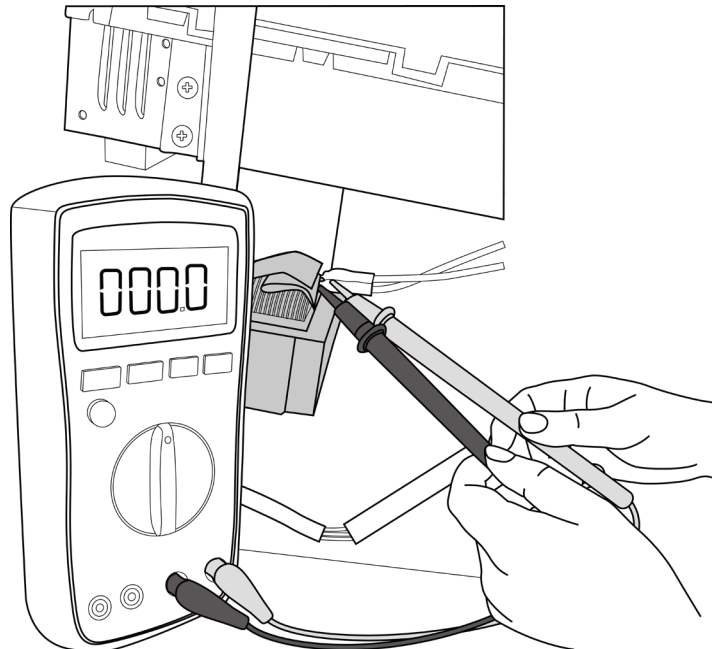

Note: The picture and the value are only for reference, actual condition and specific value may vary.

8.4 EH02(Zero crossing detection error) diagnosis and solution

Description: When PCB does not receive zero crossing signal feedback for 4 minutes or the zero crossing signal time interval is abnormal.

Recommended parts to prepare:

- Connection wires
- Indoor main PCB

Troubleshooting and repair:

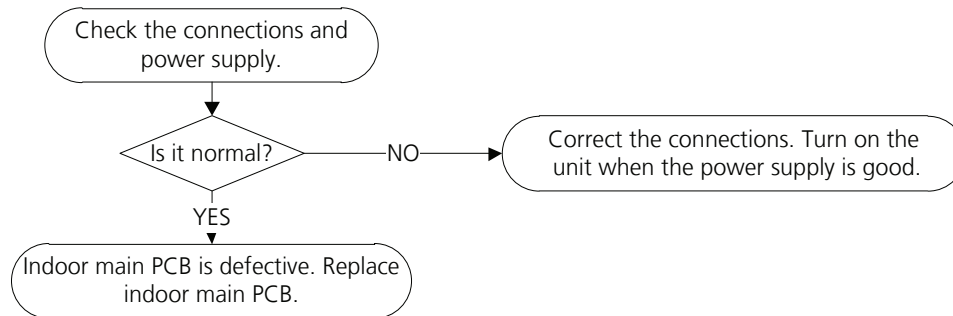

Note: Zero crossing detection error is only valid for the unit with AC fan motor, for other models, this error is invalid.

8.5 EH03(The Indoor fan speed is operating outside of normal range) diagnosis and solution

Description: When indoor fan speed keeps too low or too high for a certain time, the LED displays the failure code and the AC turns off.

Recommended parts to prepare:

- Connection wires
- Fan assembly
- Fan motor
- Indoor main PCB

Troubleshooting and repair:

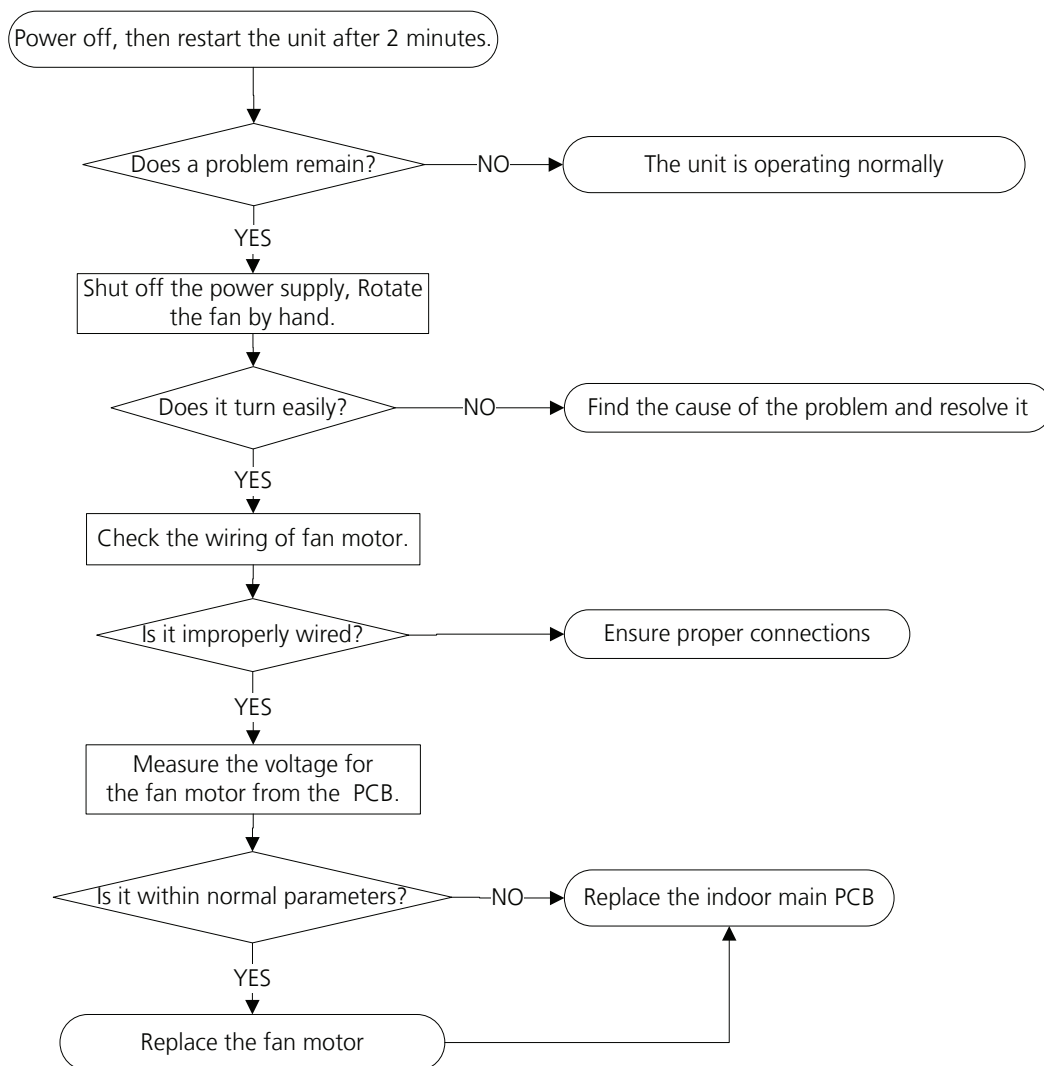

Index:

1. Indoor DC Fan Motor(control chip is in fan motor)

Power on and when the unit is in standby, measure the voltage of pin1-pin3, pin4-pin3 in fan motor connector. If the value of the voltage is not in the range showing in below table, the PCB must has problems and need to be replaced.

- DC motor voltage input and output (voltage: 220-240V~):

No.	Color	Signal	Voltage
1	Red	Vs/Vm	192V~380V
2	---	---	---
3	Black	GND	0V
4	White	Vcc	14-17.5V
5	Yellow	Vsp	0~5.6V
6	Blue	FG	14-17.5V

- DC motor voltage input and output (voltage: 115V~):

No.	Color	Signal	Voltage
1	Red	Vs/Vm	140V~190V
2	---	---	---
3	Black	GND	0V
4	White	Vcc	14-17.5V
5	Yellow	Vsp	0~5.6V
6	Blue	FG	14-17.5V

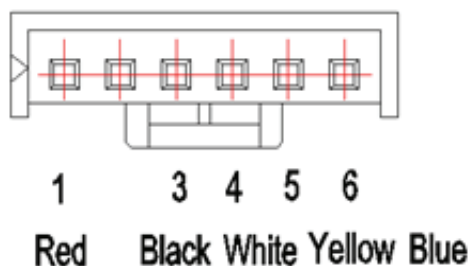

2. Indoor AC Motor

- 1) Power on and set the unit running in fan mode at high fan speed. After running for 15 seconds, measure the voltage of pin1 and pin2. If the value of the voltage is less than 100V(208~240V power supply) or 50V (115V power supply), the PCB must has problems and need to be replaced.

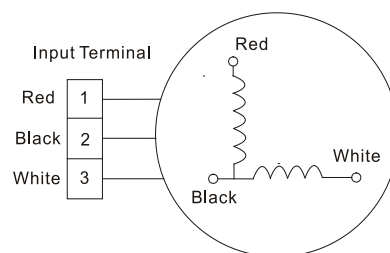

8.6 EC07/EC71(The outdoor fan speed is operating outside of normal range or Over current failure of ODU DC fan motor) diagnosis and solution

Description: When outdoor fan speed keeps too low or too high for a certain time, the LED displays the failure code and the AC turns off.

Recommended parts to prepare:

- Connection wires
- Fan assembly
- Fan motor
- Outdoor main PCB

Troubleshooting and repair:

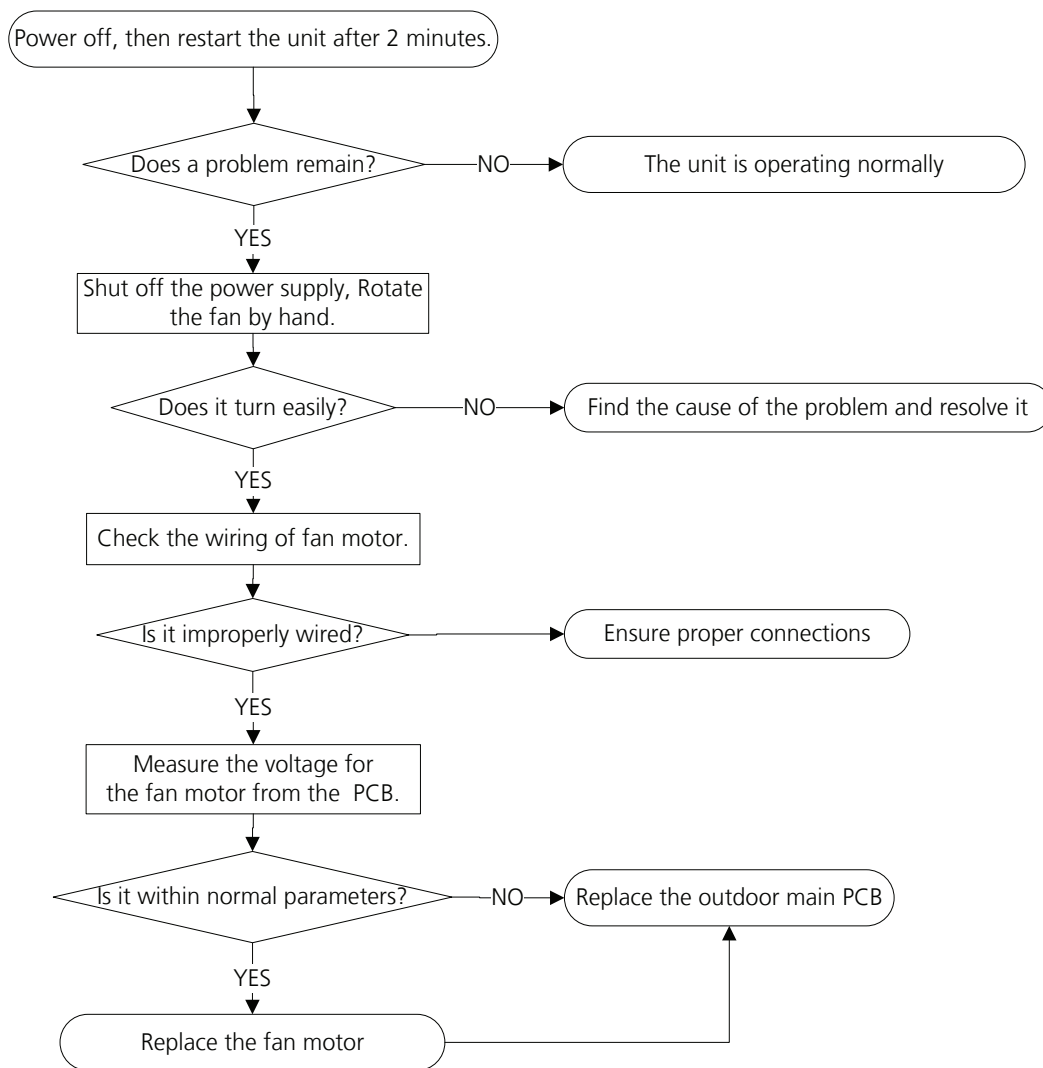

Index:**1. Outdoor DC Fan Motor (control chip is in outdoor PCB)**

Release the UVW connector. Measure the resistance of U-V, U-W, V-W. If the resistance is not equal to each other, the fan motor must have problems and need to be replaced. otherwise the PCB must have problems and need to be replaced.

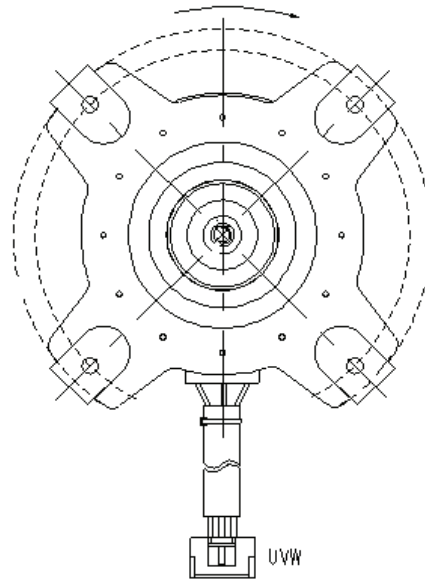
**2. DC Fan Motor(control chip is in fan motor, single fan)**

Power on and when the unit is in standby, measure the voltage of pin1-pin3, pin4-pin3 in fan motor connector. If the value of the voltage is not in the range showing in below table, the PCB must have problems and need to be replaced.

No.	Color	Signal	Voltage
1	Red	Vs/Vm	192V~380V
2	---	---	---
3	Black	GND	0V
4	White	Vcc	13.5-16.5V
5	Yellow	Vsp	0~6.5V
6	Blue	FG	13.5-16.5V

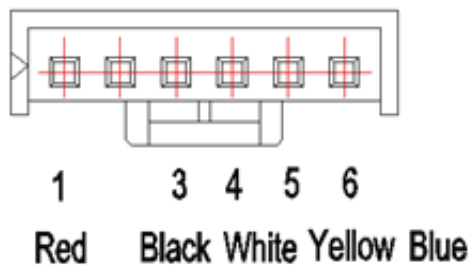

8.7 EH60/EH61(Open circuit or short circuit of indoor temperature sensor(T1, T2)) diagnosis and solution

Description: If the sampling voltage is lower than 0.06V or higher than 4.94V, the LED displays the failure code.

Recommended parts to prepare:

- Connection wires
- Sensors
- Indoor main PCB

Troubleshooting and repair:

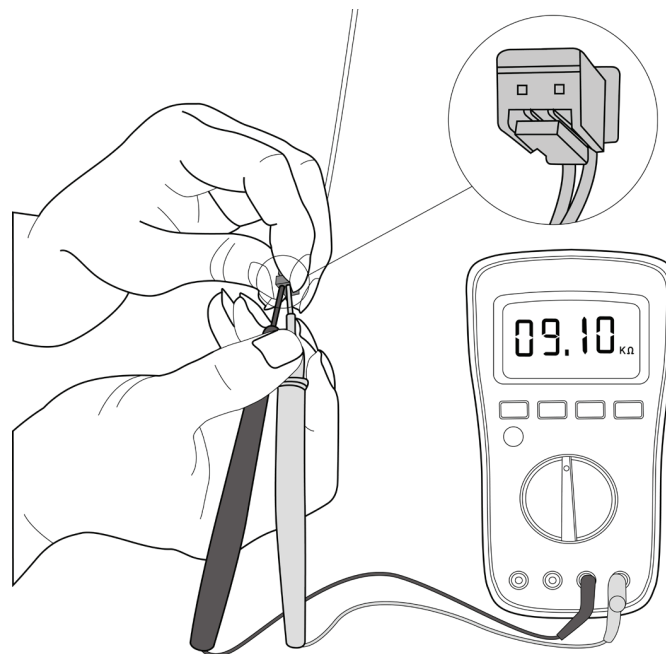
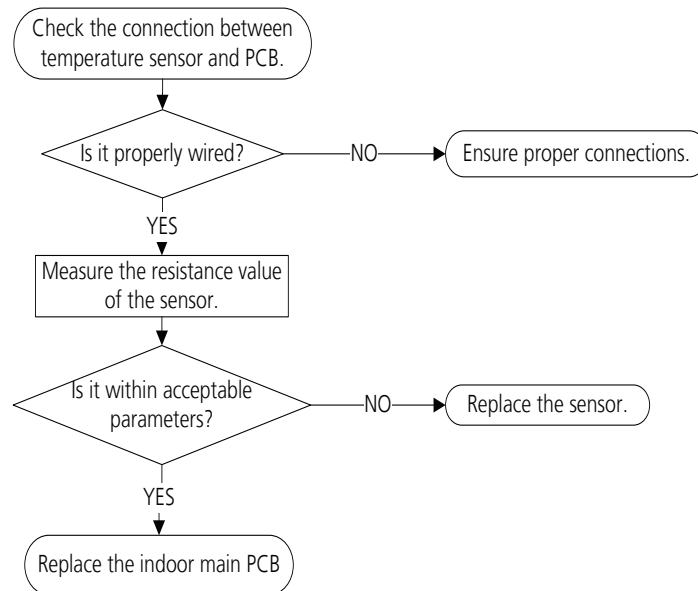

Note: This picture and the value are only for reference, actual appearance and value may vary.

8.8 EC52/EC53/EC54/EC56/EC50(Open circuit or short circuit of outdoor temperature sensor(T3, T4, TP, T2B)) diagnosis and solution

Description: If the sampling voltage is lower than 0.06V or higher than 4.94V, the LED displays the failure code.

Recommended parts to prepare:

- Connection wires
- Sensors
- Outdoor main PCB

Troubleshooting and repair:

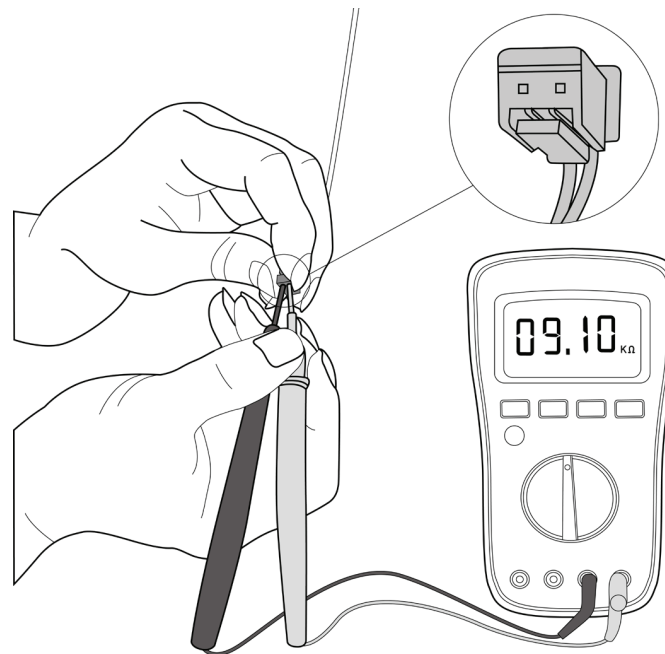
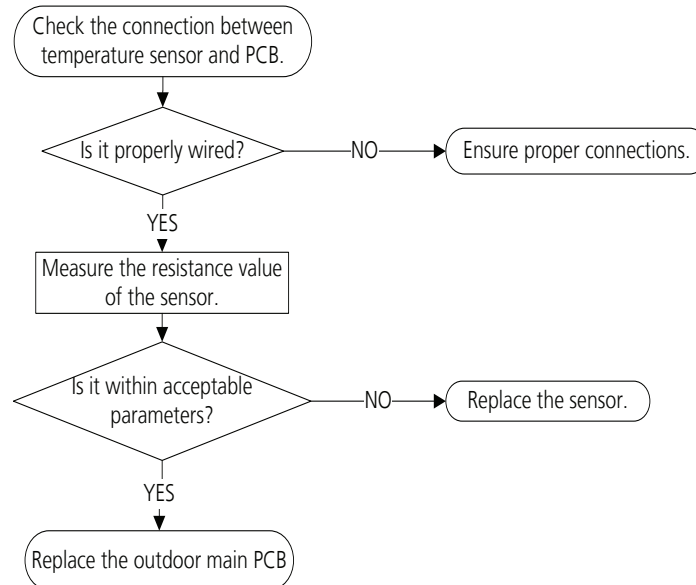

For certain models, outdoor unit uses combination sensor, T3,T4 and TP are the same of sensor. This picture and the value are only for reference, actual appearance and value may vary.

8.9 EL0C(System lacks refrigerant) diagnosis and solution

Description:

Judging the abnormality of the refrigeration system according to the number of compressor stops and the changes in operating parameters caused by excessive exhaust temperature.

Recommended parts to prepare:

- Indoor PCB
- Additional refrigerant

Troubleshooting and repair:

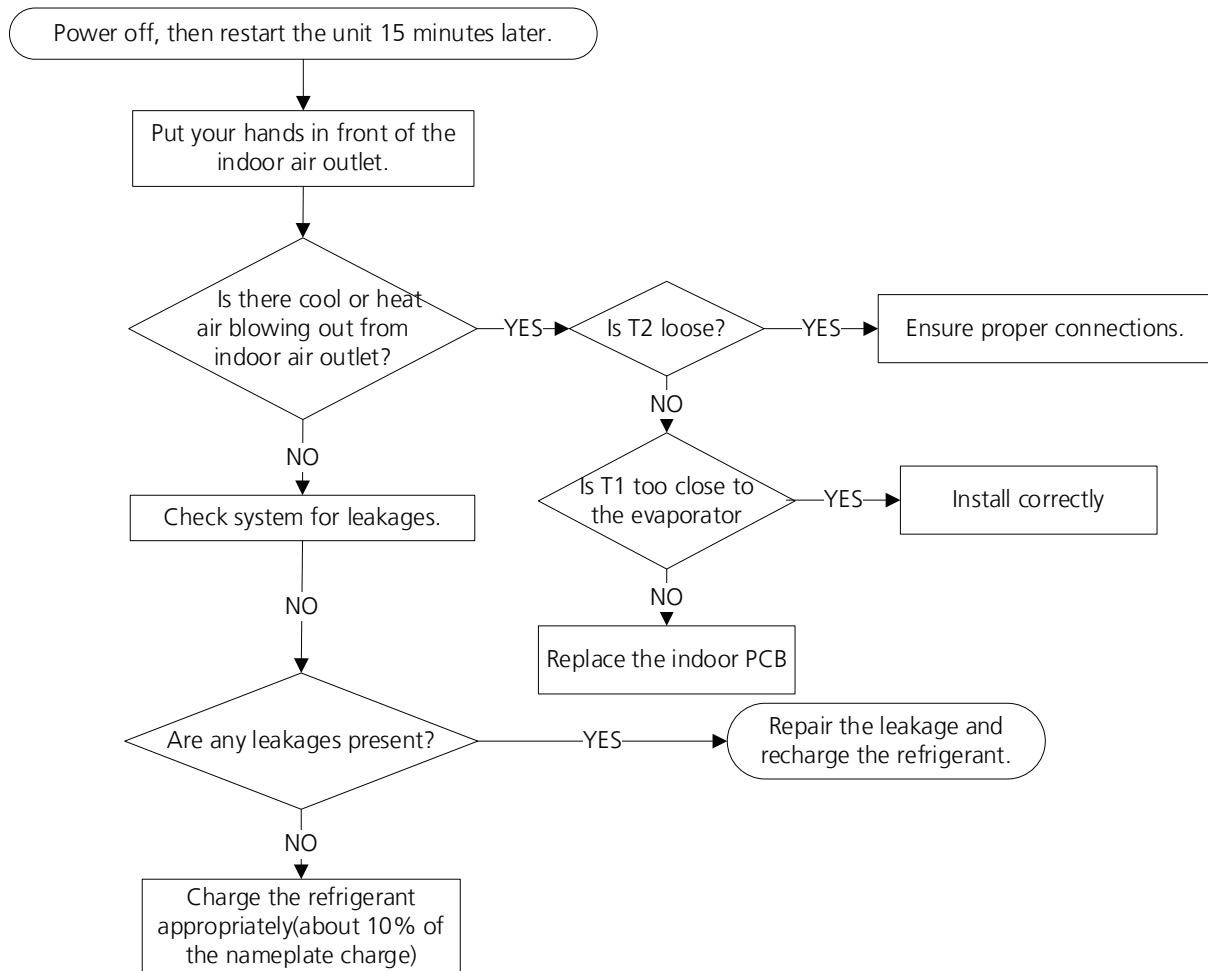

8.10 EH0b(IDU main control board and display board communication error) diagnosis and solution

Description: Indoor PCB does not receive feedback from the display board.

Recommended parts to prepare:

- Communication wire
- Indoor PCB
- Display board

Troubleshooting and repair:

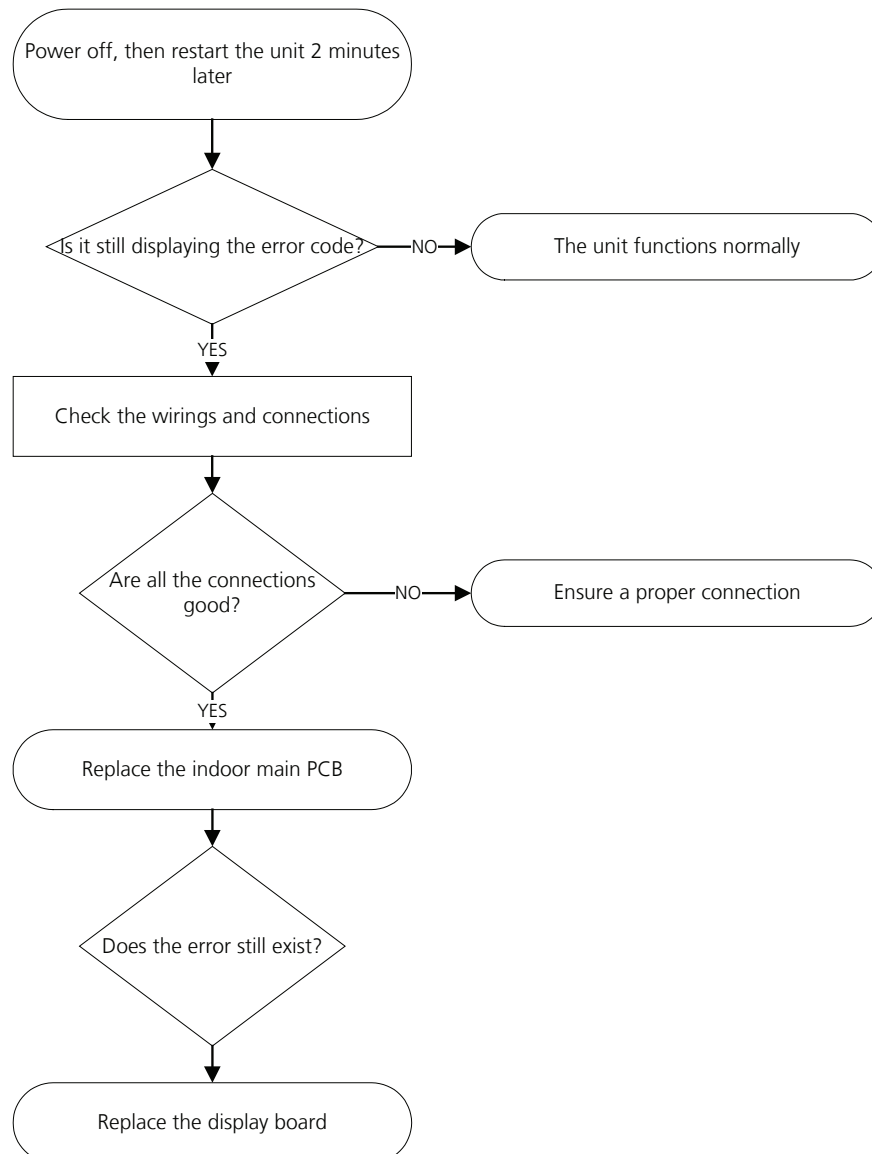

8.11 PC08(Current overload protection)/PC42(Compressor start failure of outdoor unit)/PC44(ODU zero speed protection) /PC46(Compressor speed has been out of control)/PC49(Compressor overcurrent failure) diagnosis and solution

Description: An abnormal current rise is detected by checking the specified current detection circuit.

Recommended parts to prepare:

- Connection wires
- Reactor
- Outdoor fan
- Outdoor PCB

Troubleshooting and repair:

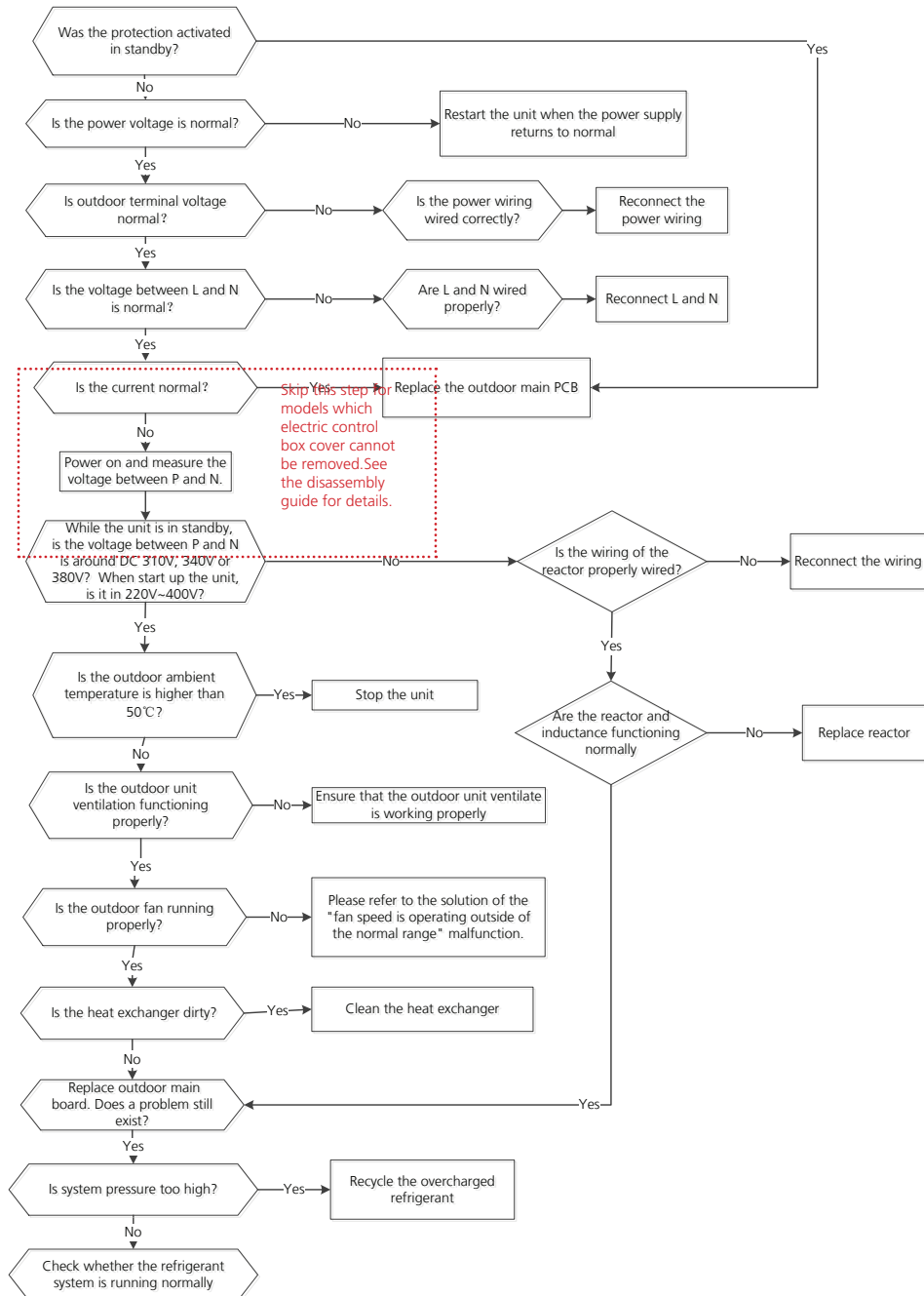

8.12 FHCC(Refrigerant sensor error) or EHC3(Refrigerant sensor is out of range) diagnosis

Description: Indoor unit receives fault signal for 10s or indoor unit does not receive feedback from refrigerant sensor for 150s.

Recommended parts to prepare:

- Connection wires
- Sensors
- Indoor main PCB

Troubleshooting and repair:

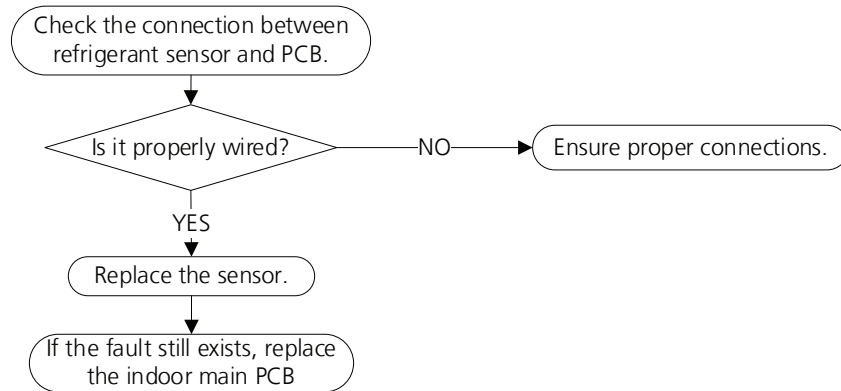

8.13 EHC1(Refrigerant sensor detects leakage) or EHC2(Refrigerant sensor is out of range and leakage is detected) diagnosis and solution

Description:

The refrigerant sensor detects a concentration higher than or equal to 10%*LFL for 10 seconds or the refrigerant sensor detects a concentration higher than or equal to 20%*LFL or the multi model receives the refrigerant leakage protection fault sent by the outdoor unit.

Multi-zone: Only the buzzer of the indoor unit that detects refrigerant leakage continues to sound the alarm, the shortest sound is 10 seconds, and the longest sound is 5 minutes (you can press any key such as remote control or wire control, APP and so on to eliminate the alarm), and the other non-refrigerant leakage fault indoor unit only displays ECC1, but the buzzer does not sound.

Recommended parts to prepare:

- Additional refrigerant

Troubleshooting and repair:

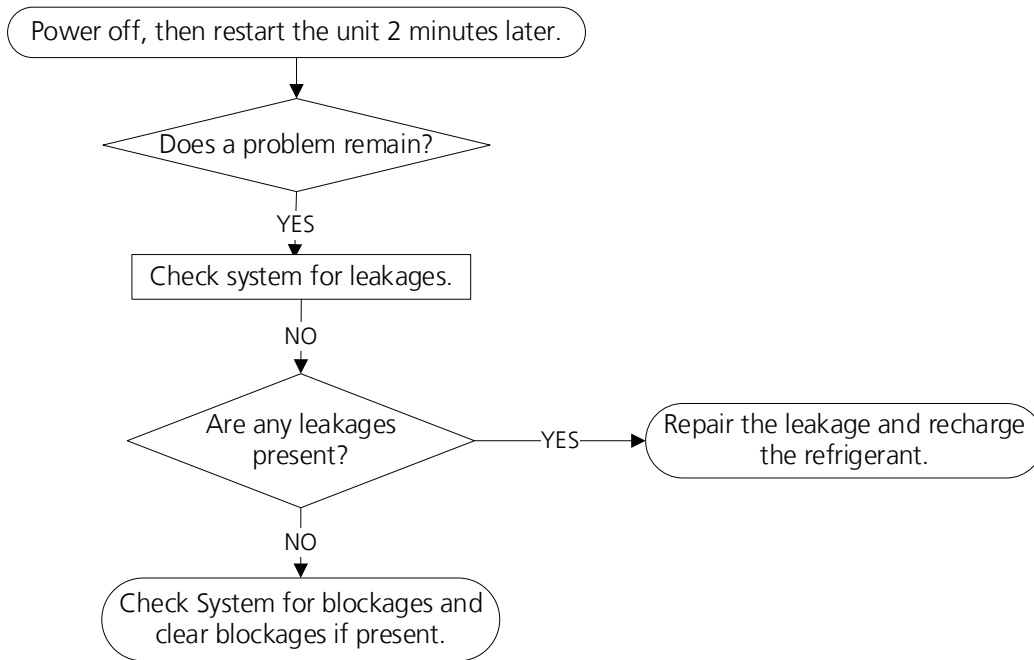

8.14 PC00(ODU IPM module protection) diagnosis and solution

Description: When the voltage signal the IPM sends to the compressor drive chip is abnormal, the LED displays the failure code and the AC turns off.

Recommended parts to prepare:

- Connection wires
- IPM module board
- Outdoor fan assembly
- Compressor
- Outdoor PCB

Troubleshooting and repair:

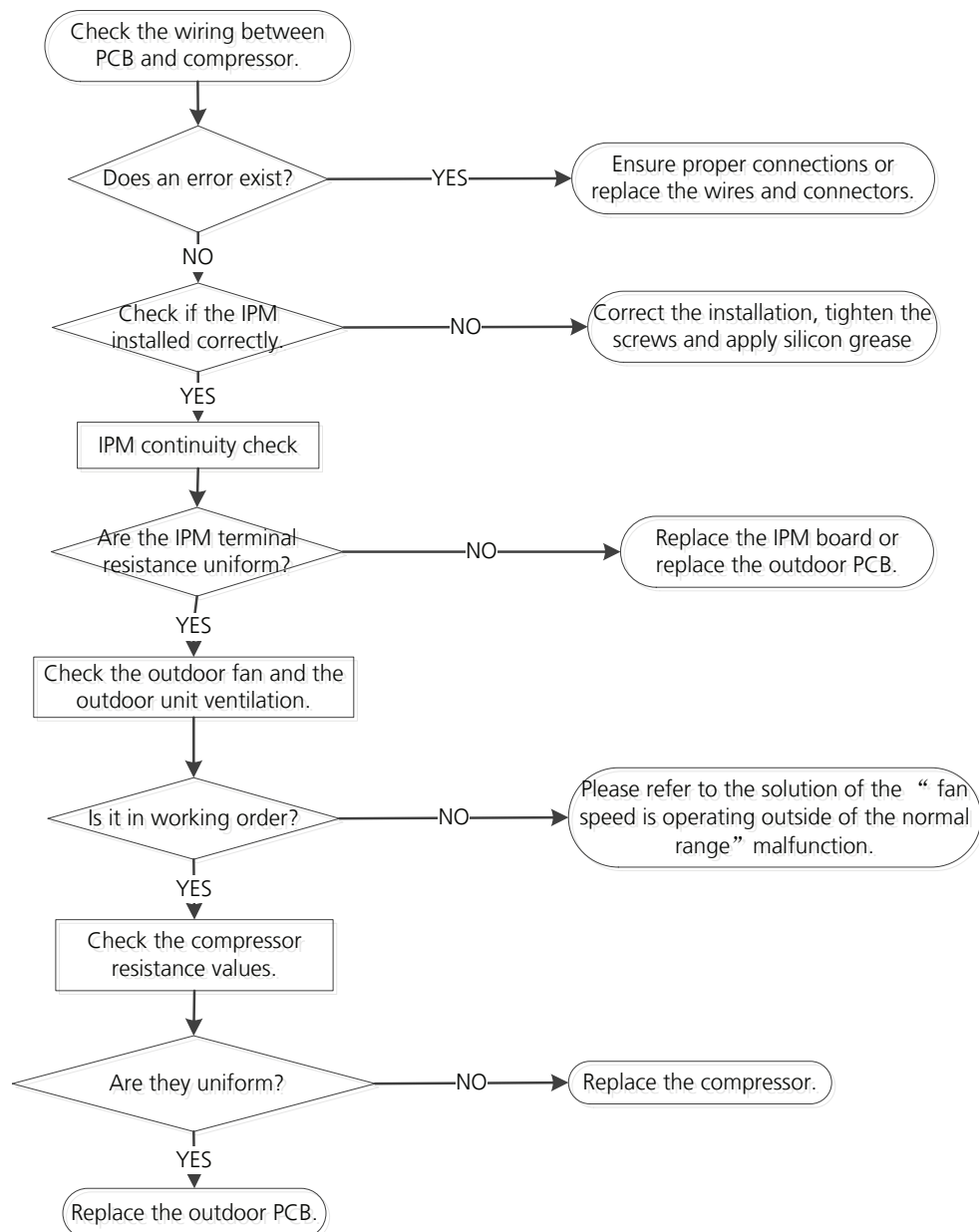

8.15 PC01(ODU voltage protection)/PC10(ODU low AC voltage protection)/PC11(ODU main control board DC bus high voltage protection)/PC12(ODU main control board DC bus low voltage protection/341 MCE error) diagnosis and solution

Description: Abnormal increases or decreases in voltage are detected by checking the specified voltage detection circuit.

Recommended parts to prepare:

- Power supply wires
- IPM module board
- PCB
- Reactor

Troubleshooting and repair:

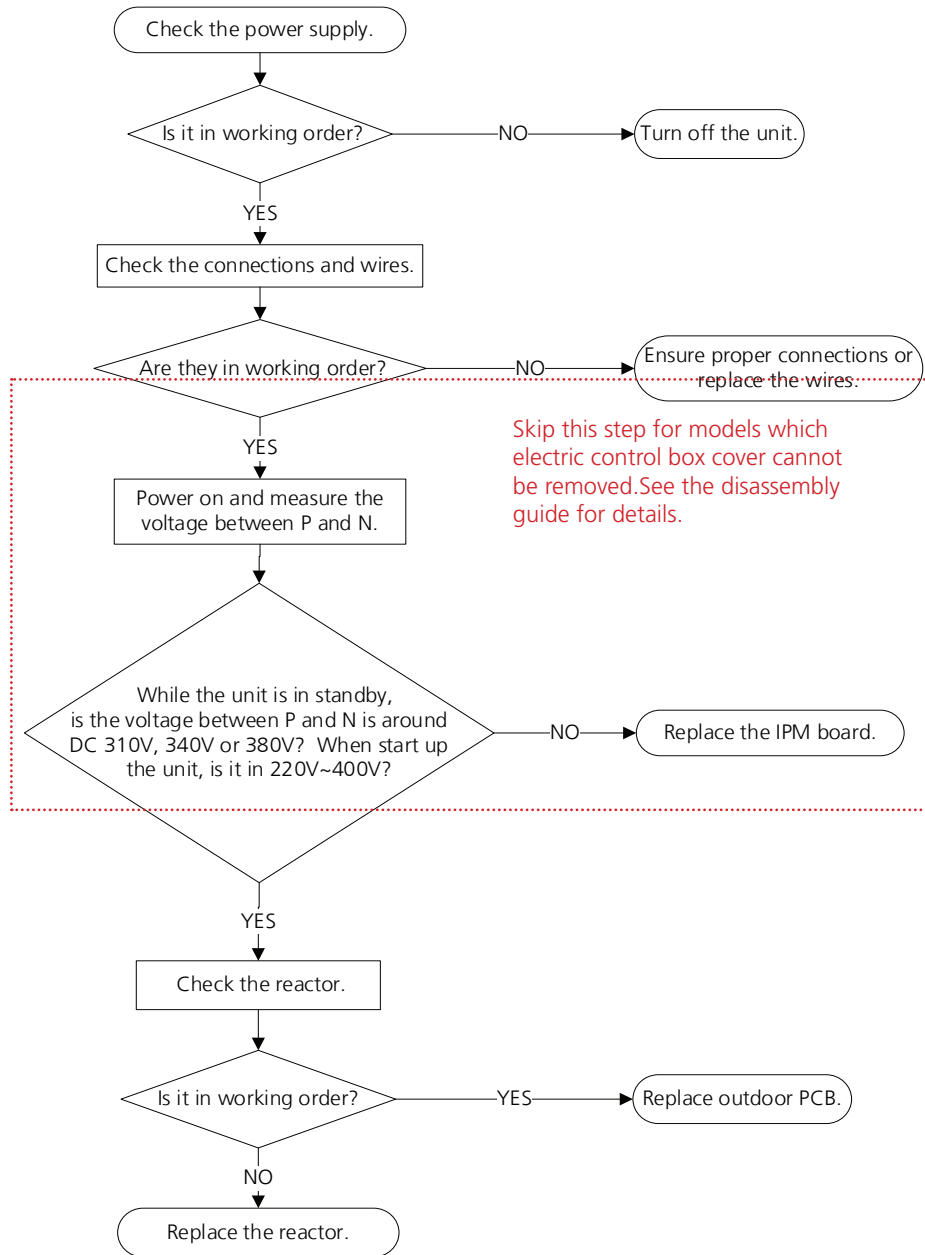

8.16 PC02/LC06 (Compressor top(or IPM) temp. protection/Refrigerant sensor error) diagnosis and solution

Description: If the temperature of IPM module is higher than a certain value, the LED displays the failure code.

Recommended parts to prepare:

- Connection wires
- Outdoor PCB
- Refrigerant sensor

Troubleshooting and repair:

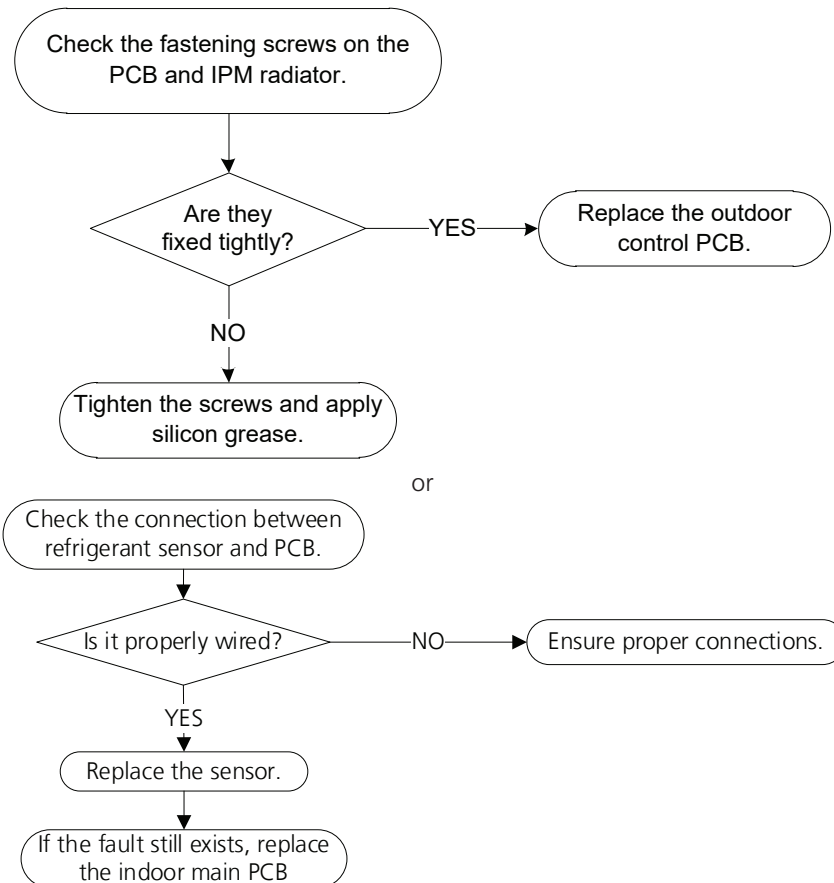

8.17 PC04(Compressor feedback protection) diagnosis and solution

Description: An abnormal inverter compressor drive is detected by a special detection circuit, including communication signal detection, voltage detection, compressor rotation speed signal detection and so on.

Recommended parts to prepare:

- Connection wires
- IPM module board
- Outdoor fan assembly
- Compressor
- Outdoor PCB

Troubleshooting and repair:

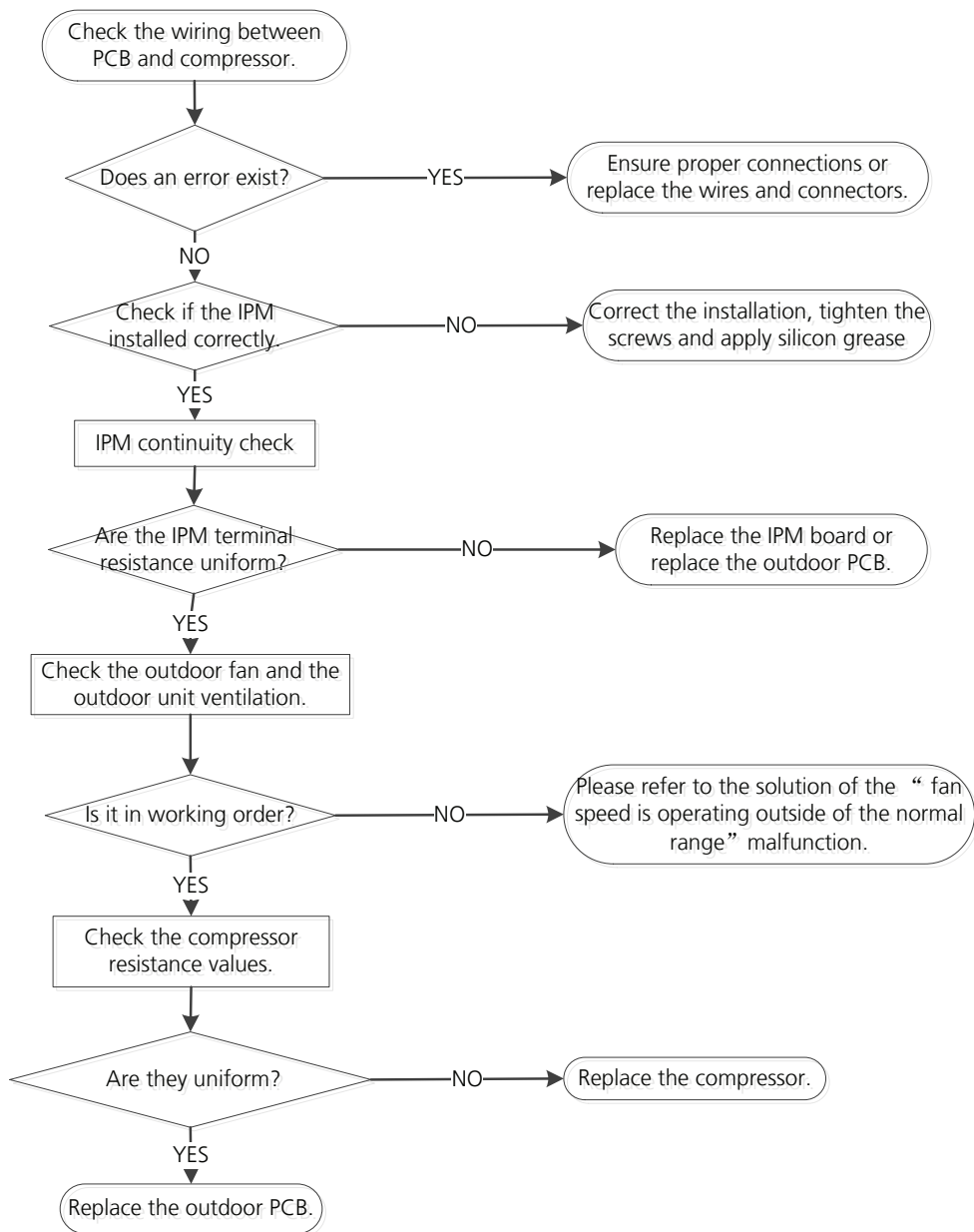

8.18 PC03/PC30/PC31(Pressure protection(low or high pressure) diagnosis and solution

Description: Outdoor pressure switch cut off the system because high pressure is higher than 4.4 MPa or outdoor pressure switch cut off the system because low pressure is lower than 0.13 MPa, the LED displays the failure code.

Recommended parts to prepare:

- Connection wires
- Outdoor PCB
- Refrigerant
- Pressure switch
- Outdoor fan

Troubleshooting and repair:

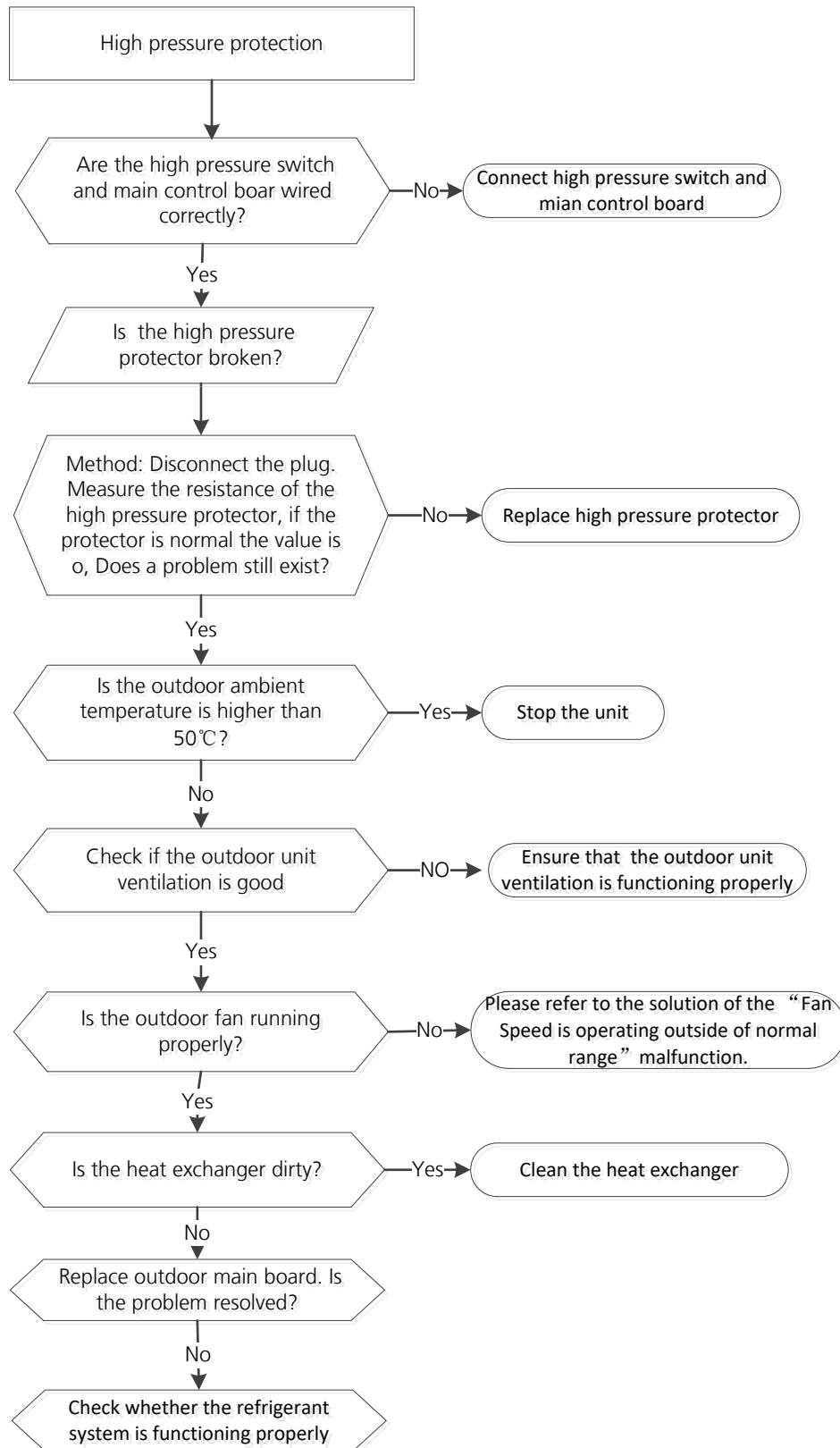

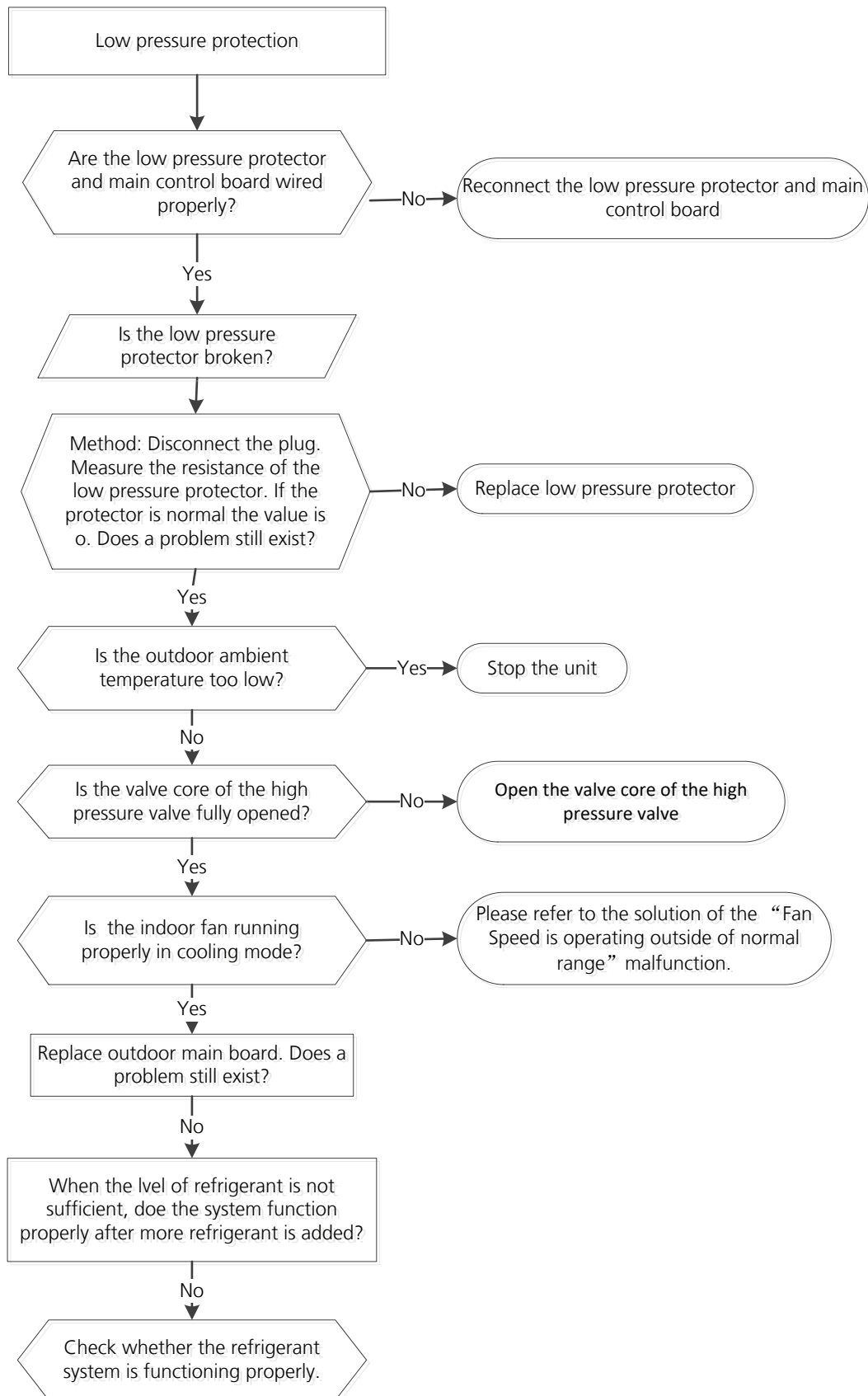

8.19 IDUs mode conflict (match with multi outdoor unit)

Description: The indoor units cannot work cooling mode and heating at same time. Heating mode has a priority.

- Suppose Indoor unit A working in cooling mode or fan mode, and indoor unit B is set to heating mode, then A will change to off and B will work in heating mode.
- Suppose Indoor unit A working in heating mode, and indoor unit B is set to cooling mode or fan mode, then B will change to stand by and A will be no change.

	Cooling mode	Heating Mode	Fan	Off
Cooling mode	No	Yes	No	No
Heating Mode	Yes	No	Yes	No
Fan	No	Yes	No	No
Off	No	No	No	No

Note:

No: No mode conflict

Yes: Mode conflict

8.20 Low temperature protection

Description: It is a protection function. When compressor is off, outdoor ambient temperature(T4) is lower than -35°C. for 10s, the AC will stop and display the failure code.

When compressor is on, outdoor ambient temperature(T4) is lower than -40°C.for 10s, the AC will stop and display the failure code.

When outdoor ambient temperature(T4) is no lower than -32°C.for 10s, the unit will exit protection.

8.21 PC0A(High temperature protection of condenser) diagnosis and solution

Description: The unit will stop when condenser temperature is higher than 65°C, and runs again when it is less than 52°C.

Recommended parts to prepare:

- Connection wires
- Condenser temperature sensor
- Outdoor fan
- Outdoor main PCB
- Refrigerant

Troubleshooting and repair:

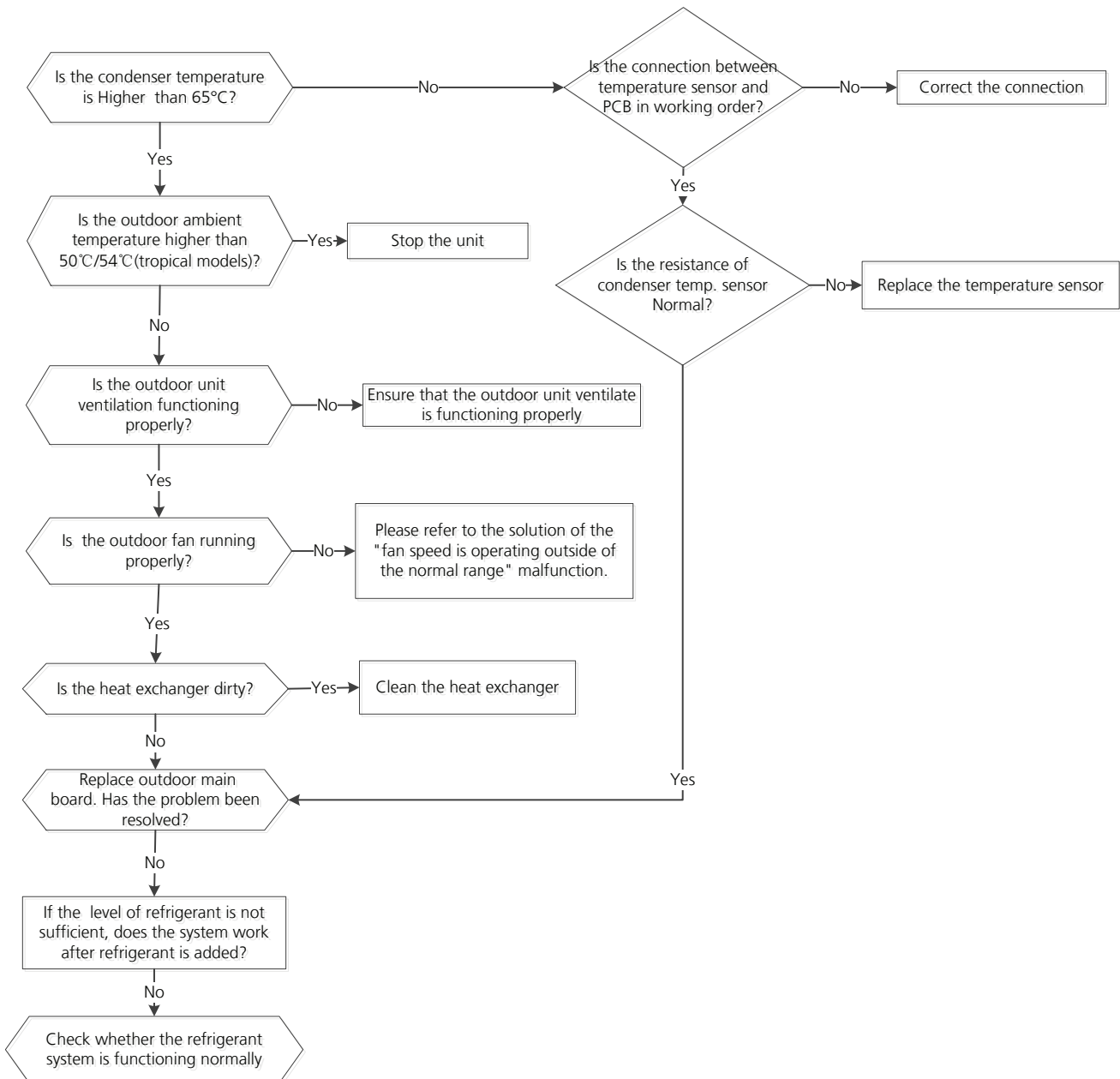

8.22 PC0F(PFC module protection) diagnosis and solution

Description: When the voltage signal that IPM send to compressor drive chip is abnormal, the LED displays the failure code and the AC turns off.

Recommended parts to prepare:

- Connection wires
- Inductance
- Outdoor main PCB
- PFC module

Troubleshooting and repair:

At first test the resistance between every two ports of U, V, W of IPM and P, N. If any result of them is 0 or close to 0, the IPM is defective. Otherwise, please follow the procedure below:

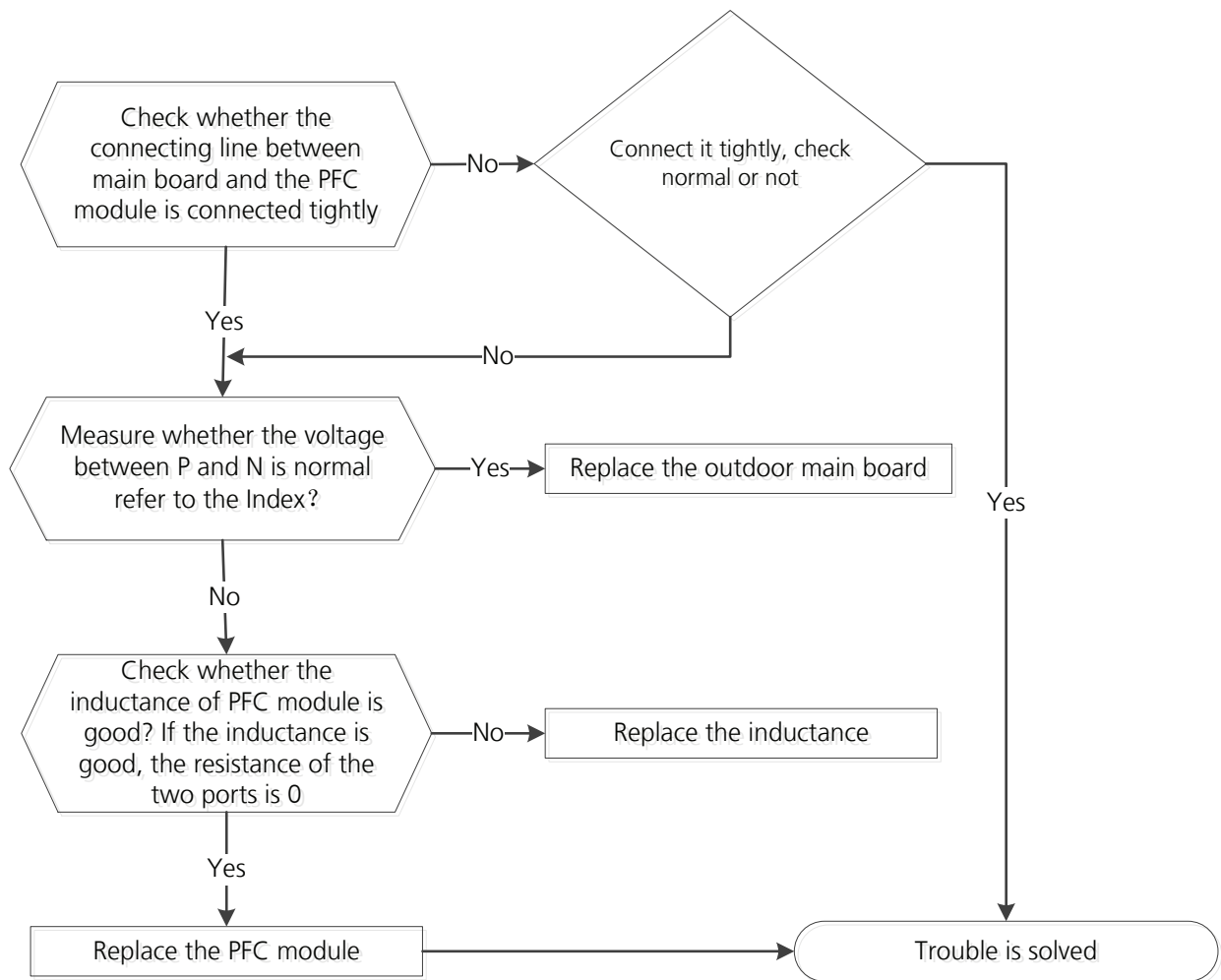

8.23 PC40(Communication error between outdoor main chip and compressor driven chip) diagnosis and solution

Description: The main PCB cannot detect the IPM board.

Recommended parts to prepare:

- Connection wires
- IPM board
- Outdoor main PCB
- Electric control box

Troubleshooting and repair:

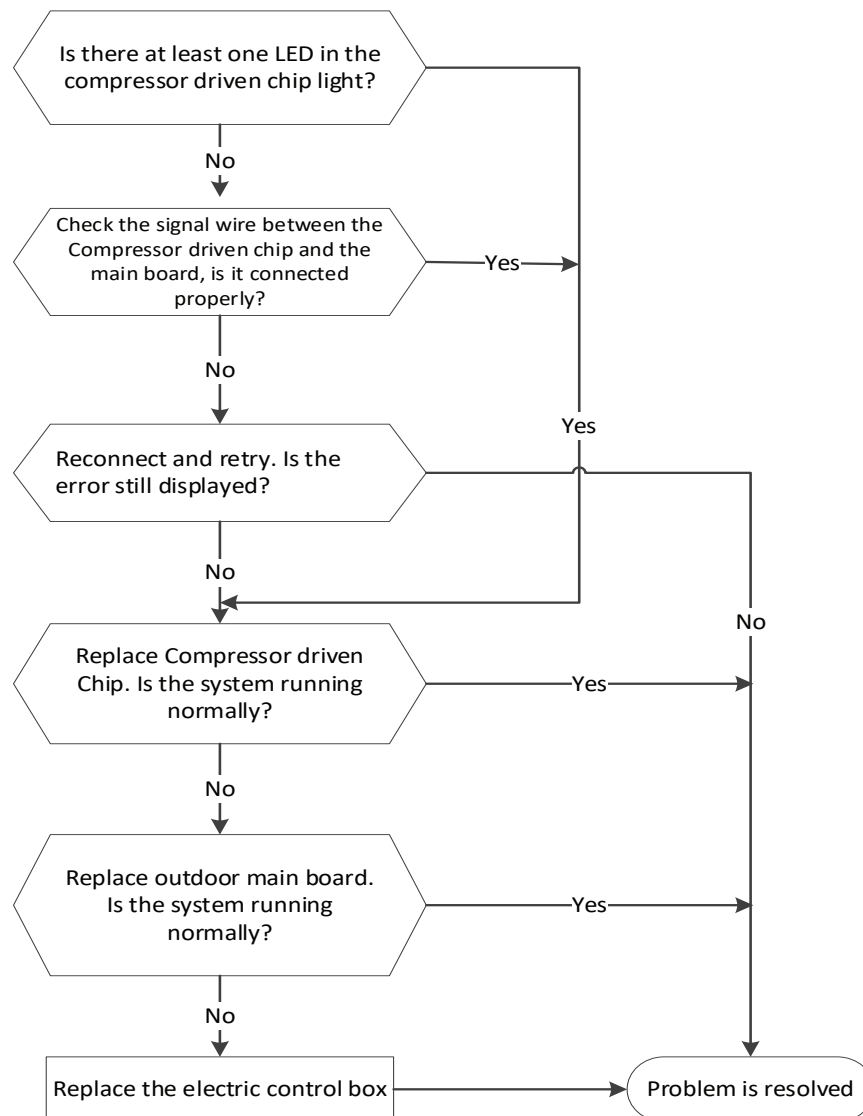

8.24 PC06(Discharge temperature protection of compressor) diagnosis and solution

Description: If the compressor discharge temperature exceeds a certain level for nine seconds, the compressor ceases operation, the LED displays the failure code

Recommended parts to prepare:

- Connection wires
- Discharge temperature sensor
- Additional refrigerant
- Outdoor main PCB

Troubleshooting and repair:

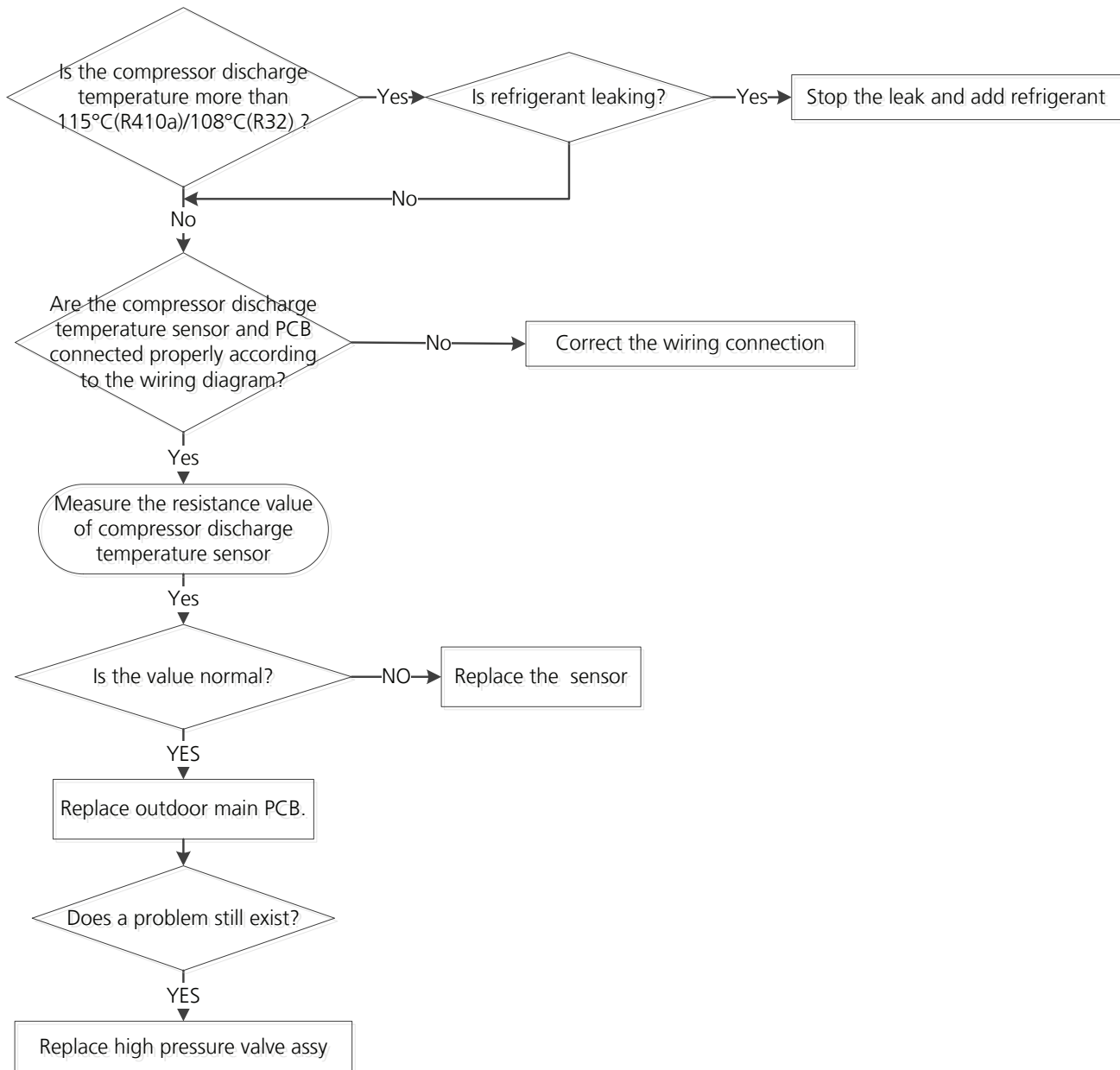

Note: For certain models, outdoor unit uses combination sensor, T3,T4 and TP are the same of sensor. This picture and the value are only for reference, actual appearance and value may vary.

8.25 EC72(Lack phase failure of ODU DC fan motor) diagnosis and solution

Description: When the three-phase sampling current of the DC motor is abnormal, especially when the current of one or more phases is always small and almost 0, the LED displays the failure code.

Recommended parts to prepare:

- Connection wire
- Fan motor
- Outdoor PCB

Troubleshooting and repair:

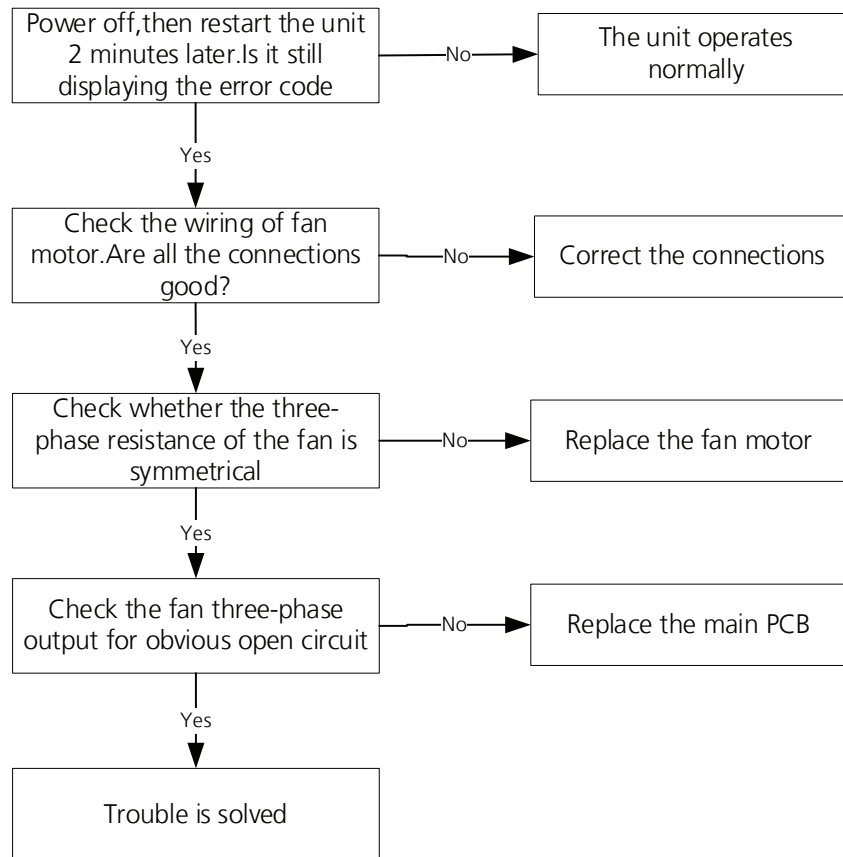

8.26 PC43(ODU compressor lack phase protection) diagnosis and solution

Description: When the three-phase sampling current of the compressor is abnormal, especially when the current of one or more phases is always small and almost 0, the LED displays the failure code

Recommended parts to prepare:

- Connection wire
- Compressor
- Outdoor PCB

Troubleshooting and repair:

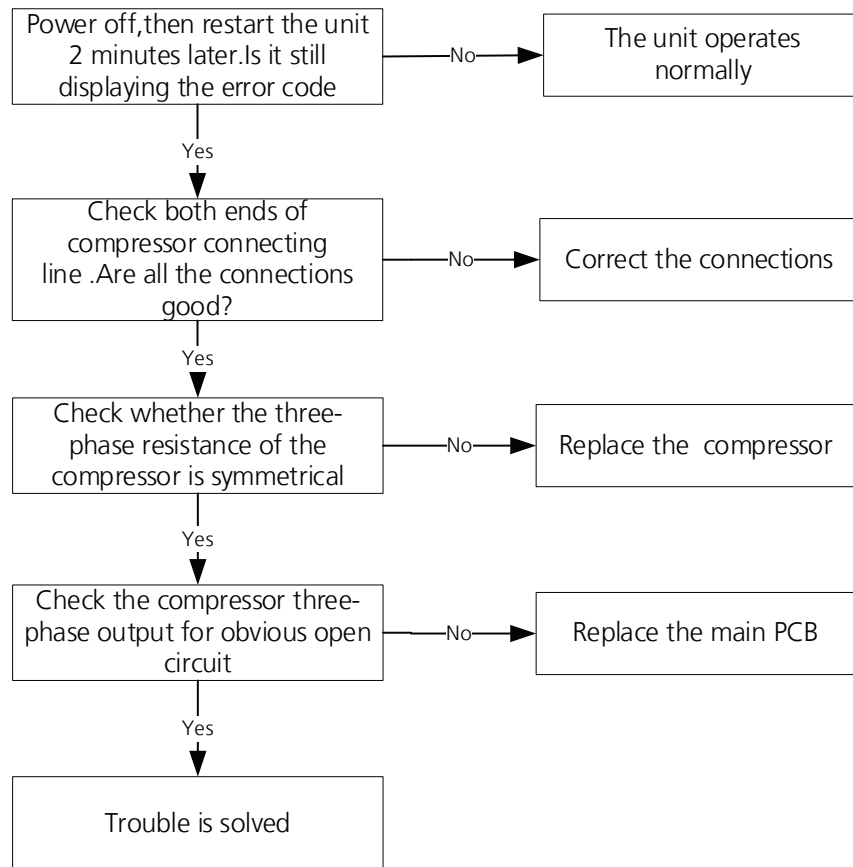

8.27 PC45(ODU IR chip drive failure) diagnosis and solution

Description: When the IR chip detects its own parameter error, the LED displays the failure code when power on.

Recommended parts to prepare:

- Inverter module PCB.

Troubleshooting and repair:

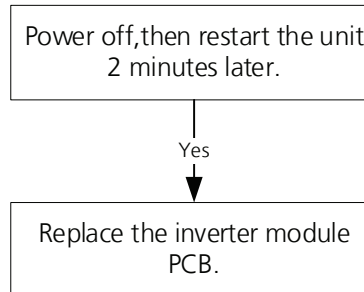

8. Check Procedures

8.1 Temperature Sensor Check

! WARNING

Be sure to turn off all power supplies or disconnect all wires to avoid electric shock. Operate after compressor and coil have returned to normal temperature in case of injury.

1. Disconnect the temperature sensor from PCB (Refer to Chapter Indoor&Outdoor Unit Disassembly).
2. Measure the resistance value of the sensor using a multi-meter.
3. Check corresponding temperature sensor resistance value table (Refer to Chapter 8. Appendix).

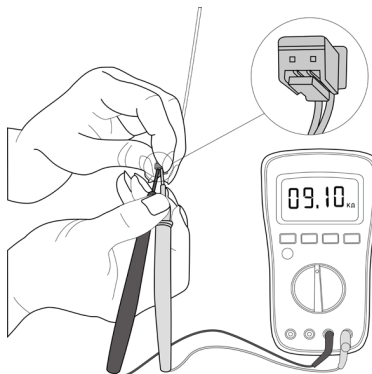

Note: The picture and the value are only for reference, actual condition and specific value may vary.

8.2 Compressor Check

1. Disconnect the compressor power cord from outdoor PCB (Refer to Chapter 6. Outdoor Unit Disassembly)).
2. Measure the resistance value of each winding using a multi-meter.
3. Check the resistance value of each winding in the following table.

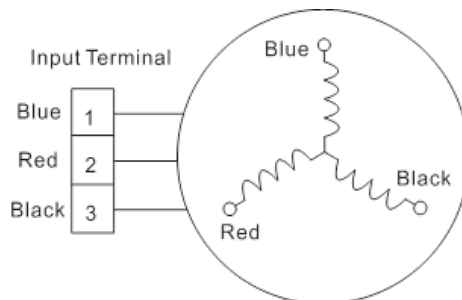

Resistance Value	KSK89D53UEZ	KSK89D29UEZD	KSN98D22UFZ	KSK103D33UEZ3 KSK103D33UEZ3(MD) KBK103D33UEZ3	KSK103D32UEZ31 KSK75D32UEZD31	KTN150D30UFZA KTN150D30SFZA
Blue-Red	2.35±5%Ω (at 20°C/68°F)	1.99±5%Ω (at 20°C/68°F)	1.57±5%Ω (at 20°C/68°F)	2.13±5%Ω (at 20°C/68°F)	4.06±5%Ω (at 20°C/68°F)	1.02±5%Ω (at 20°C/68°F)
Blue-Black						
Red-Black						

Resistance Value	KSM135D23UFZ	KTN110D42UFZ	KSN140D21UFZ	KTM140D78UFZ3	KTF235D22UMT ATF235D22TMT KTF250D22UMT	KTM240D46UKT2
Blue-Red	1.72±5%Ω (at 20°C/68°F)	1.82±5%Ω (at 20°C/68°F)	1.28±5%Ω (at 20°C/68°F)	1.5±5%Ω (at 20°C/68°F)	0.75±5%Ω (at 20°C/68°F)	1.04±5%Ω (at 20°C/68°F)
Blue-Black						
Red-Black						

Resistance Value	KSN140D58UFZ	KTM240D43UKT	KSN98D64UFZ3	ASN140D35TFZ	KTF420D62UNT	ASN108D22TEZ
Blue-Red	1.86±5%Ω (at 20°C/68°F)	1.03±5%Ω (at 20°C/68°F)	2.7±5%Ω (at 20°C/68°F)	0.83±5%Ω (at 20°C/68°F)	0.86±5%Ω (at 20°C/68°F)	1.76±5%Ω (at 20°C/68°F)
Blue-Black						
Red-Black						

Resistance Value	KTM240D63SKT2	KTM240D57UMT	DTN210D32UFZ	KSN140D33UFZB3	KTM110D79UFZA3	GSD098XKUF7JV6B
Blue-Red	1.19±5%Ω (at 20°C/68°F)	0.62±5%Ω (at 20°C/68°F)	1.7±5%Ω (at 20°C/68°F)	1.68±5%Ω (at 20°C/68°F)	1.88±5%Ω (at 20°C/68°F)	2.83±5%Ω (at 20°C/68°F)
Blue-Black						
Red-Black						

Resistance Value	KSK75D33UEZD3	DTN210D54UEZ3	DTN250D53UFZ3	KSN103D42UEZ31	KTM180D68UMT	
Blue-Red	2.14±5%Ω (at 20°C/68°F)	2.53±5%Ω (at 20°C/68°F)	1.97±5%Ω (at 20°C/68°F)	2.35±5%Ω (at 20°C/68°F)	1.91±5%Ω (at 20°C/68°F)	
Blue-Black						
Red-Black						

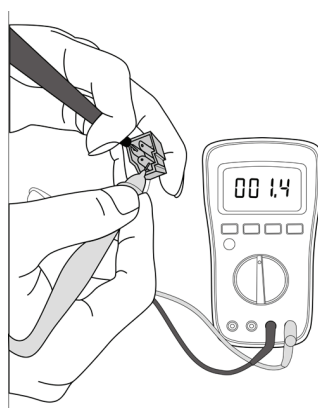

Note: The picture and the value are only for reference, actual condition and specific value may vary.

8.3 IPM Continuity Check

⚠ WARNING

Electricity remains in capacitors even when the power supply is off. Ensure the capacitors are fully discharged before troubleshooting.

1. Turn off outdoor unit and disconnect power supply.
2. Discharge electrolytic capacitors and ensure all energy-storage unit has been discharged.
3. Disassemble outdoor PCB or disassemble IPM board.
4. Measure the resistance value between P and U(V, W, N); U(V, W) and N.

Digital tester		Resistance value	Digital tester		Resistance value
(+)Red	(-)Black	∞ (Several M±5%Ω)	(+)Red	(-)Black	∞ (Several M±5%Ω)
P	N		U	N	
	U		V		
	V		W		
	W		-		

Or test the conductivity of IPM with diode mode.

Needle-type Tester		Normal Value	Needle-type Tester		Normal Value
Red	Black		Red	Black	
P	U	Open-circuit	N	U	0.3-0.5V
	V			V	
	W			W	
Needle-type Tester		Normal Value	Needle-type Tester		Normal Value
Black	Red		Black	Red	
P	U	0.3-0.5V	N	U	Open-circuit
	V			V	
	W			W	

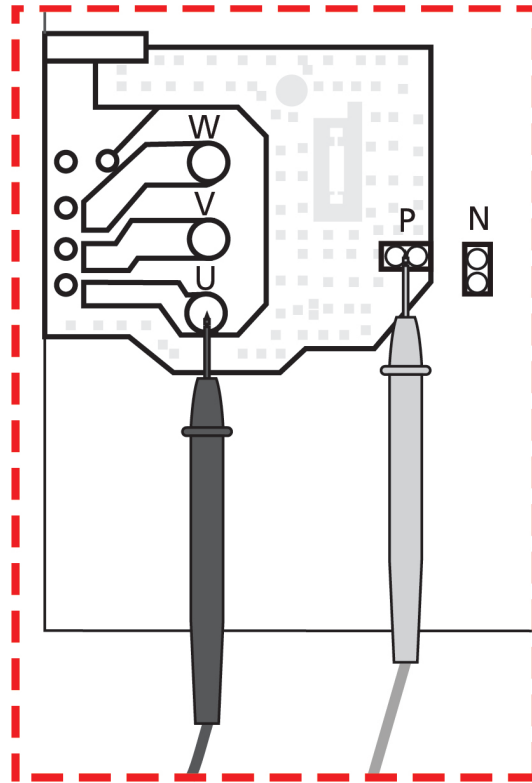

Note: The picture and the value are only for reference, actual condition and specific value may vary.

8.4 4-way Valve Check

1. Power on, use a digital tester to measure the voltage, when the unit operates in cooling, it is 0V. When the unit operates in heating, it is about 230VAC.

If the value of the voltage is not in the range, the PCB must have problems and need to be replaced.

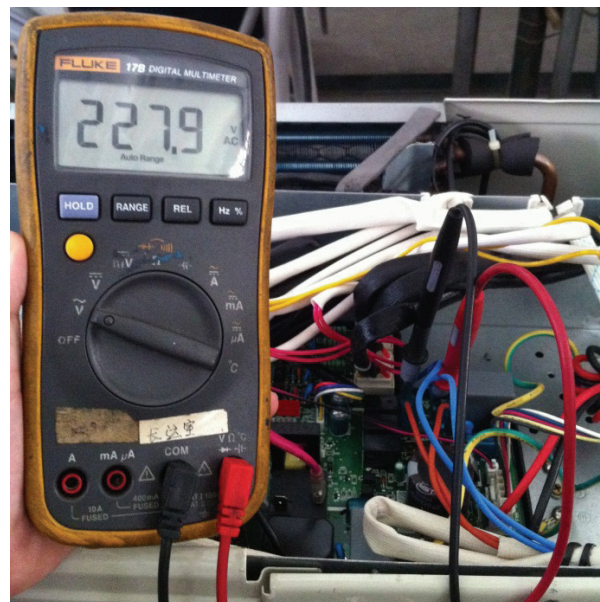

2 Turn off the power, use a digital tester to measure the resistance. The value should be $1.8\sim 2.5\text{ K}\pm 5\%\Omega$.

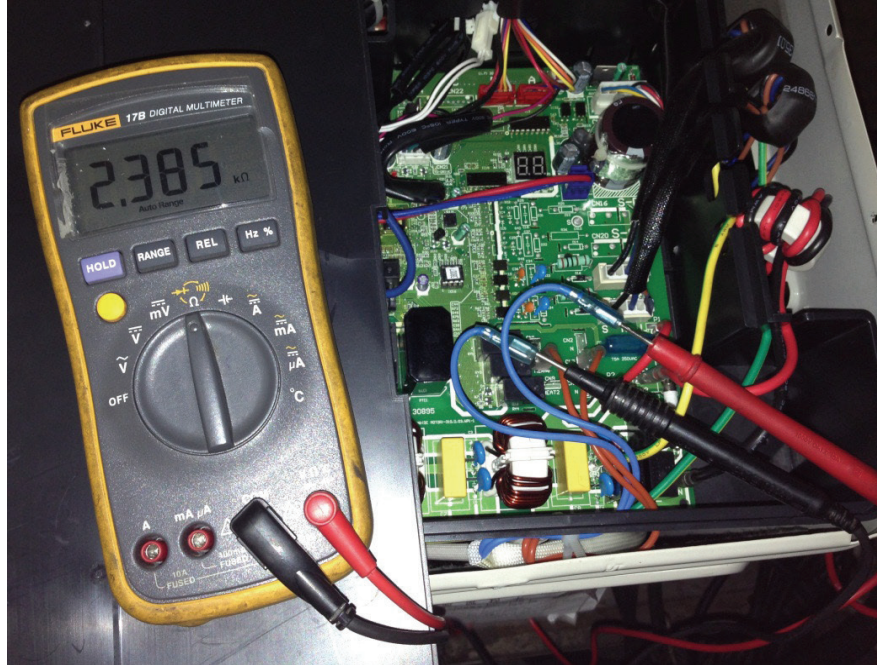

8.5 EXV Check

! WARNING

**Electricity remains in capacitors even when the power supply is off.
Ensure the capacitors are fully discharged before troubleshooting.**

1. Disconnect the connector from outdoor PCB.
2. Measure the resistance value of each winding using a multi-meter.
3. Check the resistance value of each winding in the following table.

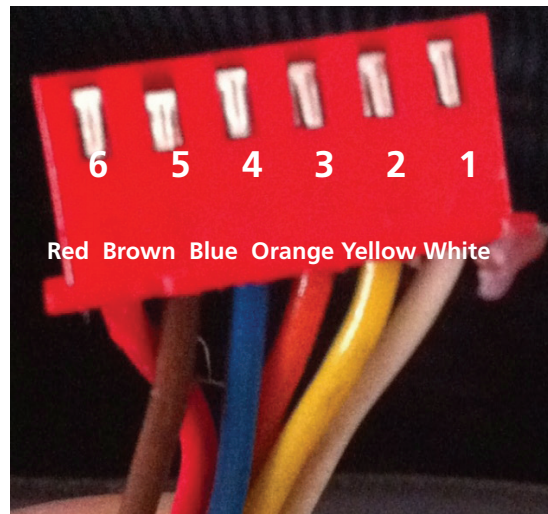

Color of lead winding	Normal Value
Red- Blue	About 50Ω
Red - Yellow	
Brown-Orange	
Brown-White	

Appendix

Contents

i)	Temperature Sensor Resistance Value Table for TP (°C --K).....	2
ii)	Other Temperature Sensors Resistance Value Table (°C – K)	3
iii)	System Pressure Table	4

i) Temperature Sensor Resistance Value Table for TP (°C --K)

°C	°F	K Ohm	°C	°F	K Ohm	°C	°F	K Ohm	°C	°F	K Ohm
°C	°F	K Ohm	°C	°F	K Ohm	°C	°F	K Ohm	°C	°F	K Ohm
-20	-4	542.7	20	68	68.66	60	140	13.59	100	212	3.702
-19	-2	511.9	21	70	65.62	61	142	13.11	101	214	3.595
-18	0	483	22	72	62.73	62	144	12.65	102	216	3.492
-17	1	455.9	23	73	59.98	63	145	12.21	103	217	3.392
-16	3	430.5	24	75	57.37	64	147	11.79	104	219	3.296
-15	5	406.7	25	77	54.89	65	149	11.38	105	221	3.203
-14	7	384.3	26	79	52.53	66	151	10.99	106	223	3.113
-13	9	363.3	27	81	50.28	67	153	10.61	107	225	3.025
-12	10	343.6	28	82	48.14	68	154	10.25	108	226	2.941
-11	12	325.1	29	84	46.11	69	156	9.902	109	228	2.86
-10	14	307.7	30	86	44.17	70	158	9.569	110	230	2.781
-9	16	291.3	31	88	42.33	71	160	9.248	111	232	2.704
-8	18	275.9	32	90	40.57	72	162	8.94	112	234	2.63
-7	19	261.4	33	91	38.89	73	163	8.643	113	235	2.559
-6	21	247.8	34	93	37.3	74	165	8.358	114	237	2.489
-5	23	234.9	35	95	35.78	75	167	8.084	115	239	2.422
-4	25	222.8	36	97	34.32	76	169	7.82	116	241	2.357
-3	27	211.4	37	99	32.94	77	171	7.566	117	243	2.294
-2	28	200.7	38	100	31.62	78	172	7.321	118	244	2.233
-1	30	190.5	39	102	30.36	79	174	7.086	119	246	2.174
0	32	180.9	40	104	29.15	80	176	6.859	120	248	2.117
1	34	171.9	41	106	28	81	178	6.641	121	250	2.061
2	36	163.3	42	108	26.9	82	180	6.43	122	252	2.007
3	37	155.2	43	109	25.86	83	181	6.228	123	253	1.955
4	39	147.6	44	111	24.85	84	183	6.033	124	255	1.905
5	41	140.4	45	113	23.89	85	185	5.844	125	257	1.856
6	43	133.5	46	115	22.89	86	187	5.663	126	259	1.808
7	45	127.1	47	117	22.1	87	189	5.488	127	261	1.762
8	46	121	48	118	21.26	88	190	5.32	128	262	1.717
9	48	115.2	49	120	20.46	89	192	5.157	129	264	1.674
10	50	109.8	50	122	19.69	90	194	5	130	266	1.632
11	52	104.6	51	124	18.96	91	196	4.849			
12	54	99.69	52	126	18.26	92	198	4.703			
13	55	95.05	53	127	17.58	93	199	4.562			
14	57	90.66	54	129	16.94	94	201	4.426			
15	59	86.49	55	131	16.32	95	203	4.294			
16	61	82.54	56	133	15.73	96	205	4.167			
17	63	78.79	57	135	15.16	97	207	4.045			
18	64	75.24	58	136	14.62	98	208	3.927			
19	66	71.86	59	138	14.09	99	210	3.812			

ii) Other Temperature Sensors Resistance Value Table (°C – K)

°C	°F	K Ohm	°C	°F	K Ohm	°C	°F	K Ohm	°C	°F	K Ohm
-20	-4	115.266	20	68	12.6431	60	140	2.35774	100	212	0.62973
-19	-2	108.146	21	70	12.0561	61	142	2.27249	101	214	0.61148
-18	0	101.517	22	72	11.5	62	144	2.19073	102	216	0.59386
-17	1	96.3423	23	73	10.9731	63	145	2.11241	103	217	0.57683
-16	3	89.5865	24	75	10.4736	64	147	2.03732	104	219	0.56038
-15	5	84.219	25	77	10	65	149	1.96532	105	221	0.54448
-14	7	79.311	26	79	9.55074	66	151	1.89627	106	223	0.52912
-13	9	74.536	27	81	9.12445	67	153	1.83003	107	225	0.51426
-12	10	70.1698	28	82	8.71983	68	154	1.76647	108	226	0.49989
-11	12	66.0898	29	84	8.33566	69	156	1.70547	109	228	0.486
-10	14	62.2756	30	86	7.97078	70	158	1.64691	110	230	0.47256
-9	16	58.7079	31	88	7.62411	71	160	1.59068	111	232	0.45957
-8	18	56.3694	32	90	7.29464	72	162	1.53668	112	234	0.44699
-7	19	52.2438	33	91	6.98142	73	163	1.48481	113	235	0.43482
-6	21	49.3161	34	93	6.68355	74	165	1.43498	114	237	0.42304
-5	23	46.5725	35	95	6.40021	75	167	1.38703	115	239	0.41164
-4	25	44	36	97	6.13059	76	169	1.34105	116	241	0.4006
-3	27	41.5878	37	99	5.87359	77	171	1.29078	117	243	0.38991
-2	28	39.8239	38	100	5.62961	78	172	1.25423	118	244	0.37956
-1	30	37.1988	39	102	5.39689	79	174	1.2133	119	246	0.36954
0	32	35.2024	40	104	5.17519	80	176	1.17393	120	248	0.35982
1	34	33.3269	41	106	4.96392	81	178	1.13604	121	250	0.35042
2	36	31.5635	42	108	4.76253	82	180	1.09958	122	252	0.3413
3	37	29.9058	43	109	4.5705	83	181	1.06448	123	253	0.33246
4	39	28.3459	44	111	4.38736	84	183	1.03069	124	255	0.3239
5	41	26.8778	45	113	4.21263	85	185	0.99815	125	257	0.31559
6	43	25.4954	46	115	4.04589	86	187	0.96681	126	259	0.30754
7	45	24.1932	47	117	3.88673	87	189	0.93662	127	261	0.29974
8	46	22.5662	48	118	3.73476	88	190	0.90753	128	262	0.29216
9	48	21.8094	49	120	3.58962	89	192	0.8795	129	264	0.28482
10	50	20.7184	50	122	3.45097	90	194	0.85248	130	266	0.2777
11	52	19.6891	51	124	3.31847	91	196	0.82643	131	268	0.27078
12	54	18.7177	52	126	3.19183	92	198	0.80132	132	270	0.26408
13	55	17.8005	53	127	3.07075	93	199	0.77709	133	271	0.25757
14	57	16.9341	54	129	2.95896	94	201	0.75373	134	273	0.25125
15	59	16.1156	55	131	2.84421	95	203	0.73119	135	275	0.24512
16	61	15.3418	56	133	2.73823	96	205	0.70944	136	277	0.23916
17	63	14.6181	57	135	2.63682	97	207	0.68844	137	279	0.23338
18	64	13.918	58	136	2.53973	98	208	0.66818	138	280	0.22776
19	66	13.2631	59	138	2.44677	99	210	0.64862	139	282	0.22231

iii) System Pressure Table-R454B

Pressure			Temperature		Pressure			Temperature	
Kpa	bar	PSI	°C	°F	Kpa	bar	PSI	°C	°F
58.196	0.58	8.44	-60	-76	935.23	9.35	135.64	8	46.4
61.517	0.62	8.92	-59	-74.2	963.75	9.64	139.78	9	48.2
64.988	0.65	9.43	-58	-72.4	992.93	9.93	144.01	10	50
68.615	0.69	9.95	-57	-70.6	1022.8	10.23	148.34	11	51.8
72.402	0.72	10.50	-56	-68.8	1053.3	10.53	152.76	12	53.6
76.354	0.76	11.07	-55	-67	1084.5	10.85	157.29	13	55.4
80.478	0.80	11.67	-54	-65.2	1116.4	11.16	161.91	14	57.2
84.776	0.85	12.30	-53	-63.4	1149	11.49	166.64	15	59
89.256	0.89	12.95	-52	-61.6	1182.3	11.82	171.47	16	60.8
93.923	0.94	13.62	-51	-59.8	1216.3	12.16	176.40	17	62.6
98.781	0.99	14.33	-50	-58	1251.1	12.51	181.45	18	64.4
103.84	1.04	15.06	-49	-56.2	1286.6	12.87	186.60	19	66.2
109.1	1.09	15.82	-48	-54.4	1322.8	13.23	191.85	20	68
114.56	1.15	16.61	-47	-52.6	1359.9	13.60	197.23	21	69.8
120.25	1.20	17.44	-46	-50.8	1397.7	13.98	202.71	22	71.6
126.15	1.26	18.30	-45	-49	1436.3	14.36	208.31	23	73.4
132.28	1.32	19.18	-44	-47.2	1475.7	14.76	214.02	24	75.2
138.64	1.39	20.11	-43	-45.4	1515.9	15.16	219.85	25	77
145.24	1.45	21.06	-42	-43.6	1557	15.57	225.82	26	78.8
152.09	1.52	22.06	-41	-41.8	1598.9	15.99	231.89	27	80.6
159.18	1.59	23.09	-40	-40	1641.6	16.42	238.09	28	82.4
166.54	1.67	24.15	-39	-38.2	1685.2	16.85	244.41	29	84.2
174.15	1.74	25.26	-38	-36.4	1729.7	17.30	250.86	30	86
182.04	1.82	26.40	-37	-34.6	1775	17.75	257.43	31	87.8
190.2	1.90	27.59	-36	-32.8	1821.3	18.21	264.15	32	89.6
198.65	1.99	28.81	-35	-31	1868.4	18.68	270.98	33	91.4
207.39	2.07	30.08	-34	-29.2	1916.5	19.17	277.95	34	93.2
216.42	2.16	31.39	-33	-27.4	1965.6	19.66	285.08	35	95
225.76	2.26	32.74	-32	-25.6	2015.5	20.16	292.31	36	96.8
235.41	2.35	34.14	-31	-23.8	2066.5	20.67	299.71	37	98.6
245.37	2.45	35.59	-30	-22	2118.4	21.18	307.24	38	100.4
255.67	2.56	37.08	-29	-20.2	2171.3	21.71	314.91	39	102.2
266.29	2.66	38.62	-28	-18.4	2225.2	22.25	322.73	40	104
277.25	2.77	40.21	-27	-16.6	2280.2	22.80	330.70	41	105.8
288.56	2.89	41.85	-26	-14.8	2336.1	23.36	338.81	42	107.6
300.22	3.00	43.54	-25	-13	2393.2	23.93	347.09	43	109.4
312.24	3.12	45.28	-24	-11.2	2451.3	24.51	355.52	44	111.2
324.63	3.25	47.08	-23	-9.4	2510.4	25.10	364.09	45	113
337.39	3.37	48.93	-22	-7.6	2570.7	25.71	372.84	46	114.8
350.54	3.51	50.84	-21	-5.8	2632.1	26.32	381.74	47	116.6
364.08	3.64	52.80	-20	-4	2694.7	26.95	390.82	48	118.4
378.02	3.78	54.83	-19	-2.2	2758.3	27.58	400.04	49	120.2
392.37	3.92	56.91	-18	-0.4	2823.2	28.23	409.46	50	122
407.13	4.07	59.05	-17	1.4	2889.3	28.89	419.04	51	123.8

422.31	4.22	61.25	-16	3.2	2956.5	29.57	428.79	52	125.6
437.92	4.38	63.51	-15	5	3025	30.25	438.72	53	127.4
453.98	4.54	65.84	-14	6.8	3094.7	30.95	448.83	54	129.2
470.47	4.70	68.23	-13	8.6	3165.7	31.66	459.13	55	131
487.43	4.87	70.69	-12	10.4	3238.1	32.38	469.63	56	132.8
504.84	5.05	73.22	-11	12.2	3311.7	33.12	480.30	57	134.6
522.73	5.23	75.81	-10	14	3386.7	33.87	491.18	58	136.4
541.1	5.41	78.48	-9	15.8	3463	34.63	502.25	59	138.2
559.95	5.60	81.21	-8	17.6	3540.7	35.41	513.52	60	140
579.31	5.79	84.02	-7	19.4	3619.9	36.20	525.00	61	141.8
599.16	5.99	86.90	-6	21.2	3700.5	37.01	536.69	62	143.6
619.54	6.20	89.85	-5	23	3782.7	37.83	548.61	63	145.4
640.43	6.40	92.88	-4	24.8	3866.3	38.66	560.74	64	147.2
661.86	6.62	95.99	-3	26.6	3951.5	39.52	573.10	65	149
683.82	6.84	99.18	-2	28.4	4038.3	40.38	585.69	66	150.8
706.34	7.06	102.44	-1	30.2	4126.8	41.27	598.52	67	152.6
729.41	7.29	105.79	0	32	4217	42.17	611.60	68	154.4
753.06	7.53	109.22	1	33.8	4309	43.09	624.95	69	156.2
777.28	7.77	112.73	2	35.6	4402.9	44.03	638.56	70	158
802.08	8.02	116.33	3	37.4	4498.7	44.99	652.46	71	159.8
827.48	8.27	120.01	4	39.2	4596.5	45.97	666.64	72	161.6
853.49	8.53	123.78	5	41	4696.5	46.97	681.15	73	163.4
880.11	8.80	127.64	6	42.8	4798.9	47.99	696.00	74	165.2
907.35	9.07	131.60	7	44.6	4904.1	49.04	711.25	75	167

Due to ongoing product improvements, specifications and dimensions are subject to change and correction without notice or incurring obligations. Determining the application and suitability for use of any product is the responsibility of the installer. Additionally, the installer is responsible for verifying dimensional data on the actual product prior to beginning any installation preparations.

Incentive and rebate programs have precise requirements as to product performance and certification. All products meet applicable regulations in effect on date of manufacture; however, certifications are not necessarily granted for the life of a product.

Therefore, it is the responsibility of the applicant to determine whether a specific model qualifies for these incentive/rebate programs.

Comfort-Aire®  **Century**®

1900 Wellworth Avenue • Jackson, MI 49203 • 517-787-2100