



Wall Mount Air Handler

SWX Series - ECM Motor

SWP Series - PSC Motor

Instruction Manual

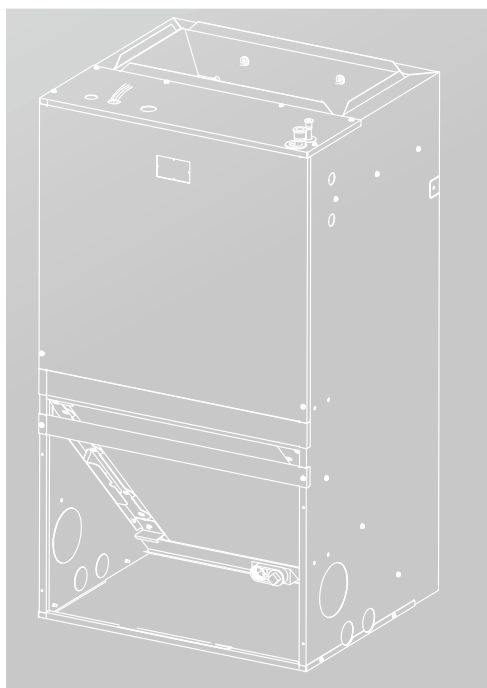



RECOGNIZE THIS SYMBOL AS AN INDICATION OF IMPORTANT SAFETY INFORMATION

WARNING

These instructions are intended as an aid to qualified licensed service personnel for proper installation, adjustment and operation of this unit. Read these instructions thoroughly before attempting installation or operation. Failure to follow these instructions may result in improper installation, adjustment, service, or maintenance, which could possibly lead to fire, electrical shock, property damage, personal injury, or even death.

Introduction

Wall mount air handlers are designed with application flexibility in mind and are suitable for closet and flush mount installations. Units are available with field-installed electric heat with circuit breaker. Units are used indoors as the fan coil for split -system heat pumps or air conditioners.

The PSC series uses a Fixed Orifice and a 3 Speed PSC Motor. ECM Series uses a TXV and a 5 speed multi-tap ECM motor for efficiency. Units are available in 24,000 through 36,000 Btu/h nominal cooling capacities. Field-installed heaters are available in 5, 7.5, and 10 kW sizes. The coil is equipped with sweat-type connections and is vapor-charged with dry nitrogen. The casing is fully insulated to meet applications in conditioned space. Additional insulation is required if the unit is installed in unconditioned space.

NOTE: Sweating may occur if the unit is installed in a humid location with low airflow.

Units are designed for upflow applications only. Local codes may limit this free-air-return type unit to installation in single-level applications.

IMPORTANT: These units are designed specifically for R-454B refrigerant and must be used only with compatible R-454B refrigerant air conditioners and heat pumps as shipped.

CONTENTS

1 SAFETY	
• 1.1 Safety Signs	01
• 1.2 Safety Precautions	02
2 ABOUT THE PRODUCT	
• 2.1 Unit Dimensions	07
• 2.2 Parts Introduction	08
• 2.3 Attached Fittings	08
3 INSTALLATION	
• 3.1 Check Equipment	09
• 3.2 Mount Air Handler	09
• 3.3 Conversion to Bottom Return	10
• 3.4 TXV	11
• 3.5 Leak Dissipation System	11
• 3.6 Refrigerant Charge and Room Area Limitations	12
4 REFRIGERANT LINE	16
5 AIRFLOW PERFORMANCE	17
6 DUCTWORK	18
7 ABOUT THE AIR FILTER	
• 7.1 Air Filter (Not Factory-Installed)	19
• 7.2 Filter Installation Dimensions	19
8 DRAIN PIPE INSTALLATION	20
9 ELECTRICAL WIRING	
• 9.1 Control Wiring	23
• 9.2 Power Wiring	27
• 9.3 Alarm Wiring	29
• 9.4 Electric Heater Kit	30
10 Dip Switch Settings	32
11 SERVICE	
• 11.1 Error Code and Troubleshooting	33
• 11.2 Piston Installation	33
12 DISPOSAL	33

This document is customer property and is to remain with this unit.
 These instructions do not cover all the different variations nor does it provide for every possible contingency to be met in connection with installation.
 All phases of this installation must comply with national state and local codes. If additional information is required, please contact your local distributor.

1 SAFETY

1.1 Safety Signs



This is the general warning sign. It is used to alert the user to potential hazards. All safety messages that follow this sign shall be obeyed to avoid possible harm.

⚠ DANGER
indicates a hazardous situation which, if not avoided, will result in death or serious injury
⚠ WARNING
indicates a hazardous situation which, if not avoided, could result in death or serious injury
⚠ CAUTION
indicates a hazardous situation which, if not avoided, could result in minor or moderate injury
NOTICE
is used to address practices not related to physical injury

Explanation of symbols displayed on the unit

	DANGER	This symbol shows that this appliance uses a mildly flammable refrigerant. If the refrigerant gets leaked and exposed to an external ignition source, there is a risk of fire.
	WARNING	This symbol shows the appliance shall be installed, operated and stored in a room with a floor area not less than the minimum room area.
	CAUTION	This symbol shows that the operation manual should be read carefully.
	CAUTION	This symbol shows that a service personnel should be handling this equipment with reference to the installation manual.
	CAUTION	This symbol shows that information is available such as in the operating manual or installation manual.

1.2 Safety Precautions

⚠ DANGER

Disconnect all power to unit before installing or servicing. More than one disconnect switch may be required to de-energize the equipment. Hazardous voltage can cause severe personal injury or death.

⚠ WARNING

If removal of the blower assembly is required, all disconnect switches supplying power to the equipment must be de-energized and locked (if not in sight of unit), so the field power wires can be safely removed from the blower assembly. Failure to do so may cause electrical shock, resulting in personal injury or death.

⚠ WARNING

The unit must be permanently grounded. Failure to do so may result in electrical shock, causing personal injury or death.

⚠ WARNING

Because of possible damage to equipment or personal injury, installation, service, and maintenance should be performed by a trained, qualified service personnel. Consumer service is recommended only for filter cleaning / replacement. Never operate the unit with the access panels removed.

⚠ WARNING

These instructions are intended as an aid to qualified, licensed service personnel for proper installation, adjustment and operation of this unit. Read these instructions thoroughly before attempting installation or operation. Failure to follow these instructions may result in improper installation, adjustment, service or maintenance, possibly resulting in fire, electrical shock, property damage, personal injury or death.

⚠ CAUTION

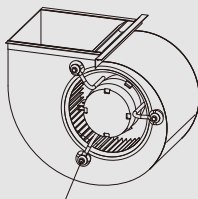

BLOWER MOTOR SHIPPING BOLT

Make sure the blower motor support is tight (3-motor mount bolts), then check if wheel is secured to the motor shaft before operating the unit.

Fig.1-1 Checking Motor Fix Status

⚠ WARNING

PROPOSITION 65: This appliance contains fiberglass insulation. Respirable particles of fiberglass are known to the State of California to cause cancer.

All manufacturer products meet current federal OSHA Guidelines for safety. California Proposition 65 warnings are required for certain products, which are not covered by the OSHA standards.

California's Proposition 65 requires warnings for products sold in California that contain or produce any of over 600 listed chemicals known to the State of California to cause cancer or birth defects such as fiberglass insulation, lead in brass, and combustion products from natural vapor.

All "new equipment" shipped for sale in California will have labels stating that the product contains and/or produces Proposition 65 chemicals. Although we have not changed our processes, having the same label on all our products facilitates manufacturing and shipping. We cannot always know "when, or if" products will be sold in the California market.

You may receive inquiries from customers about chemicals found in, or produced by, some of our heating and air-conditioning equipment, or found in natural vapor used with some of our products. Listed below are those chemicals and substances commonly associated with similar equipment in our industry and other manufacturers.

- Glass Wool (Fiberglass) Insulation
- Carbon Monoxide (CO)
- Formaldehyde
- Benzene

More details are available on the following websites: OSHA (Occupational Safety and Health Administration), at www.osha.gov and the State of California's OEHHA (Office of Environmental Health Hazard Assessment), at www.oehha.org. Consumer education is important since the chemicals and substances on the list are found in our daily lives. Most consumers are aware that products present safety and health risks, when improperly used, handled and maintained.

⚠ WARNING

The first 6 inches of supply air plenum and ductwork must be constructed of sheet metal as required by NFPA 90B. The supply air plenum or duct must have a solid sheet metal bottom directly under the unit with no openings, registers or flexible air ducts located in it. If flexible supply air ducts are used, they may be located only in the vertical walls of rectangular plenum, a minimum of 6 inches from the solid bottom. Metal plenum or duct may be connected to the combustible floor base, if not, it must be connected to the unit supply duct exposed to the supply air opening from the downflow unit. Exposing combustible (non-metal) material to the supply opening of a downflow unit can cause a fire resulting in property damage, personal injury or death.

⚠ WARNING

Only use this unit in a well-ventilated area and ensure unit's airflow inlet and outlet would not be impeded by obstructions. Do not use this unit in the following locations:

Locations with mineral oil.

Locations with saline atmospheres, such as seaside locations.

Locations with sulphurous atmospheres, such as near natural hot springs.

Where high voltage electricity is present, such as in certain industrial locations.

On vehicles or vessels, such as trucks or ferry boats.

Where exposure to oily or very humid air may occur, such as kitchens.

In proximity to sources of electromagnetic radiation, such as high-frequency transmitters or other high strength radiation devices.

⚠ WARNING

Do not use means to accelerate the defrosting process or to clean, other than those recommended by the manufacturer.

The appliance shall be stored in a room that does not have continuously operating ignition sources (for example: open flames, an operating gas appliance or an operating electric heater).

Do not pierce or burn the unit.

Be aware that refrigerants may not contain an odour.

If refrigerant gas leaks during installation, ventilate the area immediately.

Comply with national gas regulations.

⚠ WARNING

This appliance is not intended for use by people (including children) with reduced physical, sensory or mental capabilities, or people who lack experience and knowledge, unless they are supervised or have been given instructions concerning the use of the appliance by a person responsible for their safety.

Children should be supervised to ensure that they do not play with the appliance.

Any person who is involved with working on or opening a refrigerant circuit should hold a current valid certificate from an industry-accredited assessment authority, which authorizes their competence to handle refrigerants safely in accordance with an industry recognized assessment credential.

Servicing shall only be performed as recommended by the equipment manufacturer.

Maintenance and repair requiring the assistance of other skilled personnel shall be carried out under the supervision of a person competent in the use of flammable refrigerants.

Prior to beginning work on systems containing flammable refrigerants, safety checks are necessary to minimize the risk of ignition.

⚠ WARNING

When repairing the refrigerating system, comply with the following precautions prior to conducting work on the system:

– shall be undertaken according to controlled procedures so as to minimize the risk of the presence of flammable gases or vapors while the work is being performed.

– All maintenance staff and others working in the local area shall be instructed on the nature of the work being carried out. Work in confined spaces shall be avoided.

– The area shall be checked with an appropriate refrigerant detector prior to and during work, to ensure the technician is aware of potentially toxic or flammable environment. Ensure that the leak detection equipment being used is suitable for use with all applicable refrigerants, i.e. non-sparking, adequately sealed or intrinsically safe.

– If any hot work is to be conducted on the refrigerating equipment or any associated parts, appropriate fire extinguishing equipment shall be available and easily accessible. Have a dry powder or CO2 fire extinguisher adjacent to the charging area.

– When carrying out work in relation to a refrigerating system that involves exposing any pipe work, no sources of ignition shall be used in such a manner that it may lead to the risk of fire or explosion. All possible ignition sources, including cigarette smoking, should be kept sufficiently far away from the site of installation, repair, or removal and disposal of the unit, during which refrigerant can possibly be released into the surrounding space. Prior to beginning work, the area around the equipment is to be surveyed to make sure that there are no flammable hazards or ignition risks. "No Smoking" signs shall be clearly displayed.

Ensure that the area is in the open or that it is adequately ventilated before opening the system or conducting any hot work. A degree of ventilation shall continue during the period that the work is carried out. The ventilation should safely disperse any released refrigerant and preferably expel it externally into the surroundings.

Where electrical components are being changed, they shall be fit according to their purpose and to the correct specification. At all times the manufacturer's maintenance and service guidelines shall be followed. If in doubt, consult the manufacturer's technical department for assistance. The following checks shall be applied to installations using flammable refrigerants:

– The actual refrigerant charge is in accordance with the room size within which the refrigerant containing parts are installed;

– The ventilation machinery and outlets are operating adequately and are not obstructed.

– If an indirect refrigerating circuit is being used, the secondary circuit shall be checked for the presence of refrigerant.

– Equipment marking must remain visible and legible. Markings and signs that are illegible shall be corrected.

Refrigerating pipe or components are installed in a position where they are unlikely to be exposed to any substances which may corrode refrigerant containing components, unless the components are constructed of materials that are inherently resistant to corrosion or are suitably protected against corrosion.

Repair and maintenance of electrical components shall include initial safety checks and component inspection procedures. If a fault exists that could compromise safety, then no electrical supply shall be connected to the circuit until the fault has been dealt with satisfactorily.

If the fault cannot be corrected immediately but it is necessary to continue operation, an adequate temporary solution shall be used. This shall be reported to the owner of the equipment so that all parties are advised. Initial safety checks shall include:

- That capacitors are discharged: this shall be done in a safe manner to avoid the possibility of sparking;
- That no live electrical components and wiring are exposed while charging, recovering or purging the system;
- That there is continuity of grounding.

⚠ WARNING

Sealed electrical components shall be replaced.

Intrinsically safe components must be replaced.

Check that cabling will not be subject to wear, corrosion, excessive pressure, vibration, sharp edges or any other adverse environmental effects. The check shall also take into account the effects of aging or continual vibration from sources such as compressors or fans.

Under no circumstances shall potential sources of ignition be used while searching for or detecting refrigerant leaks. A halide torch (or any other detector using a naked flame) shall not be used.

Electronic leak detectors may be used to detect refrigerant leaks but, in the case of flammable refrigerants, the sensitivity may not be adequate, or may need re-calibration. (Detection equipment shall be calibrated in a refrigerant-free area.) Ensure that the detector is not a potential source of ignition and is suitable for the refrigerant used. Leak detection equipment shall be set at a percentage of the LFL of the refrigerant and shall be calibrated for the refrigerant employed, and the appropriate percentage of gas (25 % maximum) is confirmed.

If a leak is suspected, all naked flames shall be removed/extinguished.

If a leakage of refrigerant which requires brazing is found, all of the refrigerant shall be recovered from the system, or isolated (by means of shut off valves) in a part of the system remote from the leak.

Leak detection fluids are also suitable for use with most refrigerants but the use of detergents containing chlorine shall be avoided as the chlorine may react with the refrigerant and corrode the copper pipe-work.

NOTICE: Examples of leak detection fluids are -bubble method,

When breaking into the refrigerant circuit to make repairs - or for any other purpose -conventional procedures shall be used. However, for flammable refrigerants it is important that best practice be followed, since flammability is a consideration. The following procedure shall be adhered to:

- safely remove refrigerant following local and national regulations.
- evacuate.
- purge the circuit with inert gas .
- evacuate.
- continuously flush or purge with inert gas when using flame to open circuit, and.
- open the circuit.

The refrigerant charge shall be recovered into the correct recovery cylinders if venting is not allowed by local and national codes. For appliances containing flammable refrigerants, the system shall be purged with oxygen-free nitrogen to render the appliance safe for flammable refrigerants. This process might need to be repeated several times. Compressed air or oxygen shall not be used for purging refrigerant systems.

For appliances containing flammable refrigerants, refrigerants purging shall be achieved by breaking the vacuum in the system with oxygen-free nitrogen and continuing to fill until the working pressure is achieved, then venting to atmosphere, and finally pulling down to a vacuum. This process shall be repeated until no refrigerant is within the system. When the final oxygen-free nitrogen charge is used, the system shall be vented down to atmospheric pressure to enable work to take place.

The outlet for the vacuum pump shall not be close to any potential ignition sources, and ventilation shall be available.

Ensure that contamination of different refrigerants does not occur when using charging equipment. Hoses or lines shall be as short as possible to minimize the amount of refrigerant they contain.

Minimize shall be kept upright. Ensure that the refrigeration system is grounded prior to charging the system with refrigerant.

Label the system when charging is complete (if it is not already labeled).

Take extreme care not to overfill the refrigeration system.

Prior to recharging the system, it shall be pressure-tested with the appropriate purging gas. The system shall be leak-tested on completion of charging but prior to commissioning. A follow up leak test shall be carried out prior to leaving the site.

Before carrying out this procedure, it is essential that the technician is completely familiar with the equipment and all its detail. It is recommended that all refrigerants are recovered safely. Prior to the task being carried out, an oil and refrigerant sample shall be taken in case analysis is required prior to re-use of reclaimed refrigerant. It is essential that electrical power is available before the task is commenced.

- a) Become familiar with the equipment and its operation.
- b) Isolate system electrically.
- c) Before attempting the procedure ensure that:
 - mechanical handling equipment is available, if required, for handling refrigerant cylinders;
 - all personal protective equipment is available and used correctly;
 - the recovery process is supervised at all times by a competent person;
 - recovery equipment and cylinders conform to the appropriate standards.
- d) Pump down refrigerant system, if possible.
- e) If a vacuum is not possible, make a manifold so that refrigerant can be removed from various parts of the system.
- f) Make sure that the cylinder is situated on the scales before recovery takes place.
- g) Start the recovery machine and operate it in accordance with the manufacturer's instructions.
- h) Do not overfill cylinders. (No more than 80 % volume liquid charge).
- i) Do not exceed the maximum working pressure of the cylinder, even temporarily.
- j) When the cylinders have been filled correctly and the process has been completed, make sure that the cylinders and the equipment are removed from site promptly and all isolation valves on the equipment are closed off.
- k) Recovered refrigerant shall not be charged into another refrigeration system unless it has been cleaned and checked.

Equipment shall be labeled stating that it has been de-commissioned and emptied of refrigerant. The label shall be dated and signed. Ensure that there are labels on the equipment stating that the equipment contains flammable refrigerant.

When removing refrigerant from a system, either for servicing or decommissioning, it is recommended that all refrigerants are removed safely

When transferring refrigerant into cylinders, ensure that only appropriate refrigerant recovery cylinders are employed. Ensure that the correct number of cylinders for holding the total system charge is available. All cylinders to be used are designated for the recovered refrigerant and labelled for that refrigerant (i.e. special cylinders for the recovery of refrigerant). Cylinders shall be complete with pressure-relief valve and associated shut-off valves in good working order. Empty recovery cylinders are evacuated and, if possible, cooled before recovery occurs.

The recovery equipment must be in good working order and come with a set of instructions for proper usage. Furthermore the equipment should be suitable for safely recovering flammable refrigerants. If in doubt, the manufacturer should be consulted. In addition, a set of calibrated weighing scales shall be available and in good working order. Hoses shall be complete with leak-free disconnect couplings and in good condition.

The recovered refrigerant shall be processed according to local legislation in the correct recovery cylinder, and the relevant waste transfer note arranged. Do not mix refrigerants in recovery units and especially not in cylinders.

If compressors or compressor oils are to be removed, ensure that they have been evacuated to an acceptable level to be certain that flammable refrigerant does not remain within the lubricant. The compressor body shall not be heated by an open flame or other ignition sources to accelerate this process. When oil is drained from a system, it shall be carried out safely.

Do not use the air conditioner for other purposes. In order to avoid any quality deterioration, do not use the unit for the cooling of precision instruments, food, plants, animals or works of art. Before cleaning, be sure to stop the operation, turn the breaker off or unplug the supply cord. Otherwise, electric shock and injury may occur.

In order to avoid electric shock or fire, make sure that a ground leak detector is installed.

Never touch the air outlet or the horizontal blades while the swing flap is in operation. Your fingers may be caught or the unit may break down.

Never put any objects into the air inlet or outlet.

Objects touching the fan at high speed can be dangerous.

Never inspect or service the unit by yourself.

Ask a qualified service person to perform this task.

Do not dispose of this product as unsorted municipal waste. This waste should be collected separately for special treatment. Do not dispose of electrical appliances as unsorted municipal waste. Use separate collection facilities. Contact your local government for information regarding the connection systems available.

If electrical appliances are disposed of in landfills or dumps, hazardous substances can leak into the groundwater and get into the food chain, harming your health and well-being.

To prevent refrigerant leak, contact your dealer.

When the system is installed and operated in a small room, it is required to maintain the concentration of the refrigerant below the limit, in case a leak occurs. Otherwise, oxygen in the room may be affected, resulting in a serious accident.

The refrigerant in the air conditioner is safe and normally does not leak.

If the refrigerant leaks into the room and comes into contact with the fire of a burner, a heater or a cooker, a harmful gas could be released.

Turn off any combustible heating devices, ventilate the room, and contact the dealer from whom you purchased the unit.

Do not use the air conditioner until a service person confirms that the refrigerant leak is repaired.

Keep ventilation openings clear of obstruction.

⚠ CAUTION

Be sure the air conditioner is grounded. In order to avoid electric shock, make sure that the unit is grounded and that the ground wire is not connected to a gas or water pipe, lightning conductor or telephone ground wire.

Do not operate the air conditioner with wet hands. An electric shock may happen.

Do not touch the heat exchanger fins. These fins are sharp and could cut you.

To avoid oxygen deficiency, ventilate the room sufficiently if equipment with a burner is used together with the air conditioner.

Arrange the drain hose to ensure smooth drainage. Incomplete drainage may cause wetting of the building, furniture, etc.

Never touch the internal parts of the controller.

Do not remove the blower access panel. Some parts inside are dangerous to touch, and machine issues may occur.

Attention is drawn to the fact that additional transportation regulations may exist with respect to the equipment containing a flammable gas. The maximum number of pieces of equipment or the configuration of the equipment permitted to be transported together will be determined by the applicable transport regulations.

Signs for similar appliances used in a work area are generally addressed by local regulations and give the minimum requirements for the provision of safety and/or health signs for a work location.

All required signs are to be maintained and employers should ensure that employees receive suitable and sufficient instruction and

training on the meaning of appropriate safety signs and the actions that need to be taken in connection with these signs.

The effectiveness of signs should not be diminished by too many signs being placed together.

Any pictograms used should be as simple as possible and contain only essential details.

The storage of the appliance should be in accordance with the applicable regulations or instructions, whichever is more stringent.

Storage package protection should be constructed such a way that mechanical damage to the equipment inside the package will not cause a leak of the Refrigerant Charge.

The maximum number of pieces of equipment permitted to be stored together will be determined by local regulations.

Do not operate the air conditioner when using a room fumigation - type insecticide. Failure to observe this precaution could cause the chemicals to become deposited in the unit, which could endanger the health of those who are hypersensitive to chemicals. It may also cause the refrigerant sensor to alarm.

Do not place appliances which produce open flames in places exposed to the air flow from the unit or under the indoor unit. It may cause incomplete combustion or deformation of the unit due to the heat.

Do not install the air conditioner in a location where flammable gas may leak out. If the gas leaks out and stays around the air conditioner, a fire may break out.

Any additional equipment installed in our unit may not cause negative influence on normal operation, such as UV lights, humidifier and etc.

The appliance uses R454B refrigerant.



2 ABOUT THE PRODUCT

2.1 Unit Dimensions

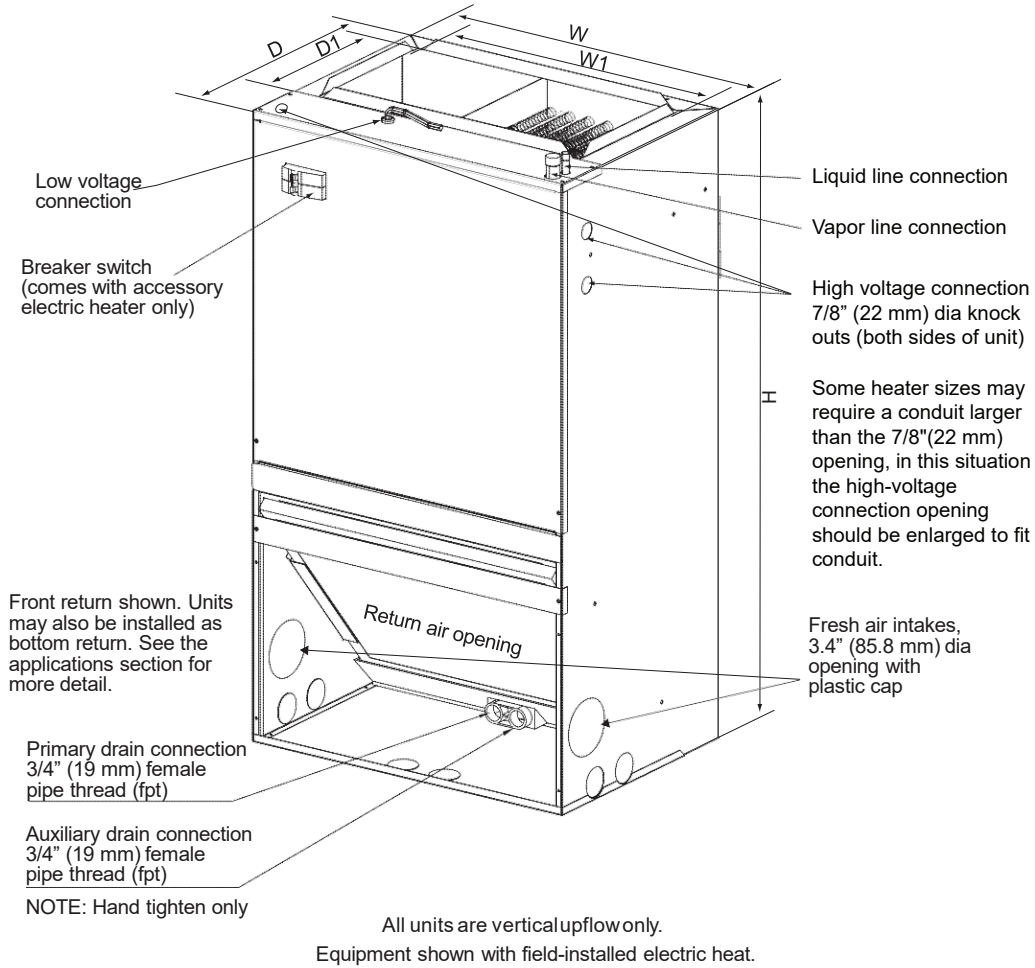

Fig. 2-1 Dimensions

Dimensional Data

Model	Unit Height "H" in [mm]	Unit Width "W" in [mm]	Unit Width "W1" in [mm]	Unit Depth "D" in [mm]	Unit Depth "D1" in [mm]	Unit Weight (lb [kg])
18	36-1/2" [928]	20-1/2" [521]	17-2/5" [442]	15" [381]	9-1/2" [242]	PSC motor– 88 (40) ECM motor– 84 (38)
24	36-1/2" [928]	20-1/2" [521]	17-2/5" [442]	15" [381]	9-1/2" [242]	PSC motor– 88 (40) ECM motor– 84 (38)
30	39-1/2" [1004]	22" [559]	18-4/5" [478]	19" [483]	9-1/2" [242]	PSC motor– 106 (48) ECM motor– 99 (45)
36	39-1/2" [1004]	22" [559]	18-4/5" [478]	19" [483]	9-1/2" [242]	PSC motor– 106 (48) ECM motor– 99 (45)

Table 2-1

2.2 Parts Introduction

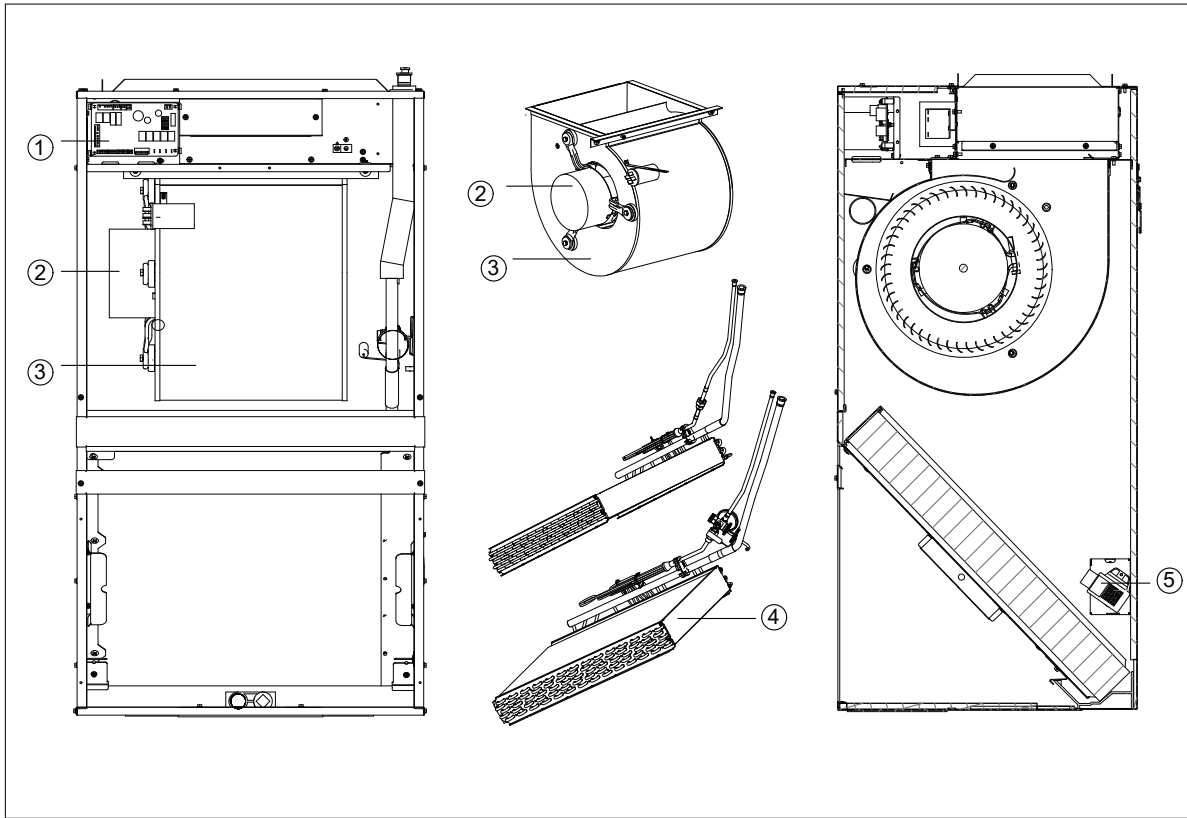

Fig. 2-2

Number	①	②	③	④	⑤
Parts	Control Board	Motor	Blower	AL-Evaporator	R454B Refrigerant Sensor

Table 2-2

2.3 Attached Fittings



Attached Fittings		
Name	Appearance	Quantity
Indoor unit operation and installation manual		1
Accessory package		1
Alarm output wires		1

Table 2-3

Note: The above list is for most models, different models of the attached fittings list may be slightly different. Check if any accessory in the above figure is missing. All the accessories must be kept properly. All the fittings should be factory fittings.

3 INSTALLATION

3.1 Check Equipment

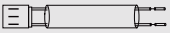
Unpack unit and move to final location. Remove carton, taking care not to damage unit. Remove protective sheet metal from the base of the unit, if equipped. Inspect equipment for damage prior to installation. File claim with shipping company if shipment is damaged or incomplete. Locate rating plate on unit. It contains information needed to properly install unit. Check rating plate to be sure unit matches job specifications. A front access panel is provided, which permits access to blower assembly and electrical controls for removal and servicing.

NOTICE

Minimum clearance of 21" (533 mm) is required in front of access panel for servicing only. Installation clearance from combustible materials is 0" (0 mm) from cabinet and supply-air duct (plenum included). Make sure there is adequate space on top of unit for refrigerant line connections and on bottom of unit for condensate trap (Fig. 8-1).

3.2 Mount Air Handler

Air Handler Mounting Options

The air handler comes standard with two different options for mounting: wall mount or frame mount. Both mounting options require the unit to be level from side to side and from front to back in order to allow condensate to properly drain from the unit. Failure to do this will result in condensate leaking out from the unit, potentially causing structural damage to the surrounding support structures, drywall, carpet, etc. around the unit. Also, both mounting structures require the ability to accommodate a minimum load of 150 pounds. Failure to do this will cause damage to the support structure and potentially damage the unit.

Wall Mount

The air handler comes standard with a wall mounting bracket and air handler mounting bracket. Refer to Fig. 3-1 for more detail.

1. Remove the wall mounting bracket from the back of the unit by removing one screw which attaches the bracket to the fan coil.

NOTICE

Discard the screw after you have removed the wall mounting bracket.

2. Install bracket on the wall by using three wood screws (not provided) per wall-mount bracket. Make sure the bracket is level in order to provide proper drainage from the unit.

NOTICE

Do not attach the wall mounting bracket into unsupported drywall. Make sure that the wood screws are going into a structure that can support a minimum load of 150 pounds.

3. Lift the air handler above the wall mounting bracket and attach the unit to the installed bracket. Refer to Fig. 3-1

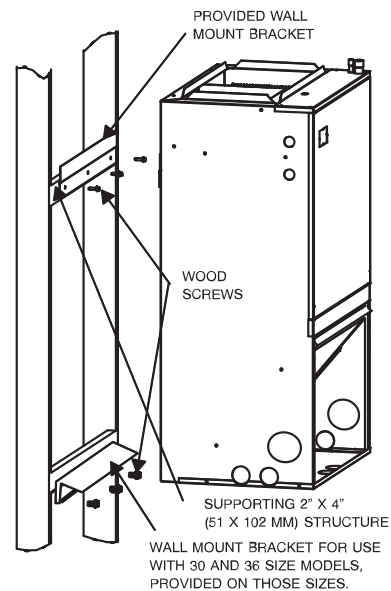
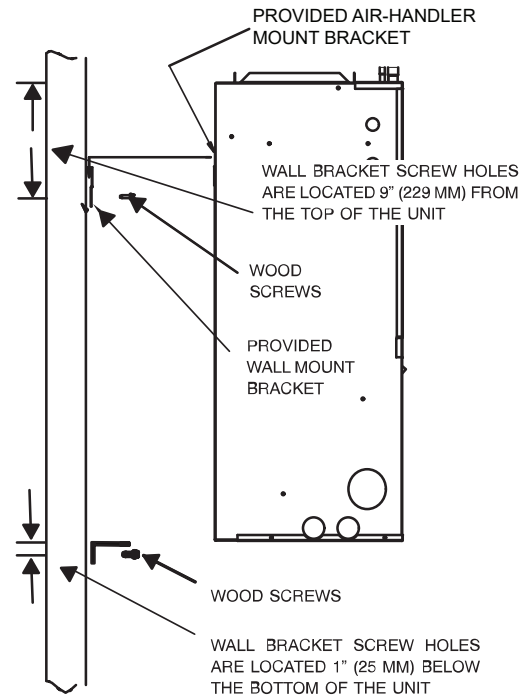

Fig. 3-1 Wall Mount Installation

NOTICE

Mounting wall and supporting structure must be able to support a minimum of 150 lb(68 kg).

Frame Mount

The air handler comes with eight clearance holes, four on each side. These holes are used to mount the air handler inside a frame structure (Fig. 3-2).

When mounting in this fashion, make sure that the wood screws are mounted from within the air handler and not outside of the unit. Installing the screws from outside of the unit may damage the coil. After moving unit into place, install refrigerant tubing as follows:

1. Route tubing to connection points, taking care not to block service access.
2. Remove plugs from liquid and vapor lines.
3. Braze connections using either silver bearing or non-silver bearing brazing material. Do not use soft solder (materials which melt below 800 °F / 427 °C). Consult local code requirements. Always flow nitrogen through the system refrigerant lines while brazing.
4. Pressurize system and leak-test. Repeat procedure until leak-free.

Ductwork Specifications

Connect supply-air duct over 3/4" (19 mm) flange provided on supply-air opening. Secure duct to flange using applicable fasteners for type of duct used, and seal duct-to-unit joint.

NOTICE

Short duct runs tend to increase noise level.

When the air handler is equipped with an electric heater, install air ducts in accordance with standards 90A and 90B of National Fire Protection Association (NFPA). Use of flexible connectors between ductwork and unit will prevent transmission of vibration. When electric heater is installed, use heat-resistant material for a flexible connector between ductwork and unit air discharge connection. Ductwork passing through unconditioned space must be insulated and covered with a vapor barrier.

NOTICE

Unit is intended for non-ducted return-air applications. Product Data sheet includes a list of accessories, including louvered wall panels and return air opening grills. If ducted return is used, airflow must meet criteria established in the Product Data. Local codes may limit this unit to single-level applications.

Design the duct system in accordance with "ACCA" Manual "D" Design for Residential Winter and Summer Conditioning and Equipment Selection. Latest editions are available from: "ACCA" Air Conditioning Contractors of America. If duct system incorporates flexible air duct, be sure pressure drop information (straight length plus all turns) shown in "ACCA" Manual "D" is accounted for in system.

⚠ WARNING

INJURY HAZARD

Failure to follow this warning could result in personal injury or death. Do not, under any circumstances, connect return ductwork to any other heat-producing device such as fireplace inserts, stoves, etc. Unauthorized use of such devices may result in fire, carbon monoxide poisoning, explosion, personal injury or property damage.

⚠ CAUTION

ENVIRONMENTAL HAZARD

Failure to follow this caution may result in environmental damage. Do not vent refrigerant to atmosphere. Recover during system repair or final unit disposal.

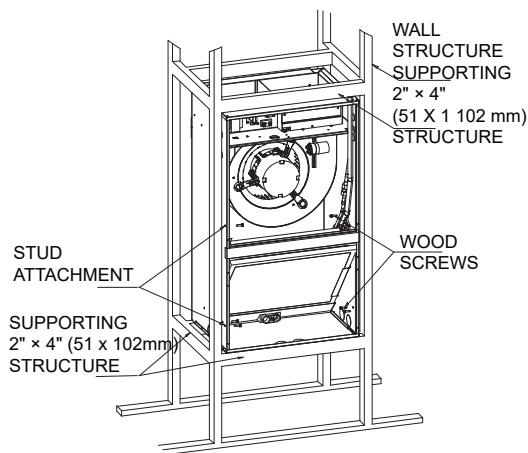

Fig. 3-2 Frame Mount Installation

3.3 Conversion to Bottom Return

This product is shipped configured for front return and can be converted for bottom return. To convert the unit to bottom return, remove the bottom panel and lower front panel (short panel above front opening and below the filter slot). Attach the panel removed from the bottom of the unit to the front return opening.

Condensate Drain

Condensate pan has primary and secondary drain connections to meet FHA requirements (Fig. 8-1). These connections have 3/4" (19 mm) female pipe threads. Tubing for all condensate drains should be a minimum of 7/8" (22 mm) OD. Drain lines from condensate pan to exterior of unit must be plastic pipe. Drain should be pitched downward at a slope of 1" per 10 feet (25 mm per 3 m). If coil is located in or above a living space where damage may result from condensate overflow, a separate 3/4" (19 mm) drain must be provided from secondary drain connection. Run this drain to a place in compliance with local installation codes where it will be noticed when unit is operational.

Condensate flow from secondary drain indicates a plugged primary drain. Install a 2" (51 mm) trap in condensate drain line as close to coil as possible. Make sure that the top of the trap is below the connection to the drain pan to prevent condensate from overflowing drain pan. Prime all traps, test for leaks, and insulate in areas where sweating of the traps and drain lines could potentially cause water damage. Consult local codes for additional restrictions or precautions. Optional extrusions are provided on the bottom panel if the installer wishes to secure the drain lines (Fig. 3-3).

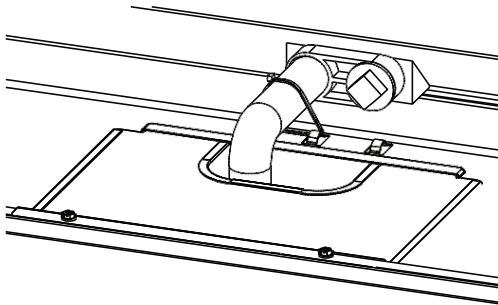

Fig. 3-3 Drain Line Tie-down Extrusions

3.4 TXV(For ECM Series)

NOTICE

The TXVs are preset at the factory and do not need adjustment for reliable operation.

WARNING

PERSONAL INJURY OR PROPERTY DAMAGE

These instructions are exclusively intended for qualified contractors and authorized installers. Work on the refrigerant circuit with flammable refrigerant in safety group A2L may only be carried out by authorized heating contractors. These heating contractors must be trained in accordance with UL60335-2-40, Section HH. The certificate of competence from an industry accredited body is required.

Work on electrical equipment may only be carried out by a qualified electrician.

Before initial commissioning, all safety related points must be checked by the particular certified heating contractors. The system must be commissioned by the system installer or a qualified person authorized by the installer.

For installation of the indoor unit, refer to the corresponding installation and operation manual. If an indoor unit is installed in an unventilated area, the area shall be so constructed that should any refrigerant leak, it will not stagnate so as to create a fire or explosion hazard. The appliance shall be stored so as to prevent mechanical damage from occurring.

Do not stack combustible materials on the surface of the indoor unit.

3.5 Leak Dissipation System

WARNING

PERSONAL INJURY OR Property Damage HAZARD

Failure to follow proper R-454B mitigation system installation instructions can result in property damage, personal injury, or death. If any fault codes are listed, please troubleshoot to prevent system malfunction.

The units come equipped with a factory wired R-454B leak detection and dissipation system to ensure safe operation during a leak. The system consists of a bracket, a PCB, an A2L Detection Sensor, and a drain pan clip. Failure to install this system will result in potentially hazardous conditions and improper equipment operation, and void all system warranties and liabilities.

All units are shipped with the A2L Detection Sensor located on the back side of the slope coil (Fig. 3-4).

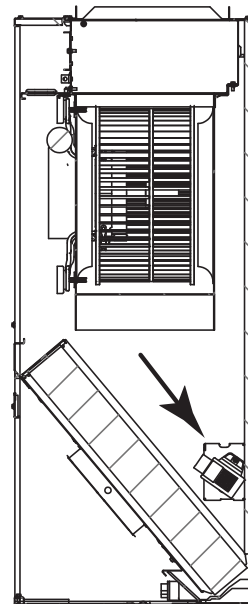

Fig. 3-4 Location of Refrigerant Sensor

The A2L Detection Sensor is attached to a wiring harness that connects the sensor to the control board. Refer to Fig. 9-5 and Fig. 9-6 for low voltage field connections between the control board and the thermostat. All control wires are labeled with the wire function and landing point.

Leak Dissipation System Self-Test

Power on the unit and verify proper functioning of equipment. The green LED on the control board should be steady (Fig. 3-5). If flash codes are present, see Table 3-1.

WARNING

The leak detection system is installed in the indoor unit. Continuous air circulation required for proper functioning. This unit is equipped with electrically powered safety measures. To be effective, the unit must be electrically powered at all times after installation, other than when servicing.

⚠ CAUTION

The refrigerant leakage sensor can only use the factory model. The R454B refrigerant leakage sensor must be used to activate the refrigerant shut-off device, the alarm device, incorporated circulation airflow or other emergency controls, which shall give an electrical signal at a predetermined alarm set point in response to leaked refrigerant.

The location of leakage sensors shall be chosen in relation to the different installation scenarios. Please refer to the indoor unit installation manual for specific requirements.

The installation of the refrigerant leakage sensor shall allow access for checking, repair or replacement by an authorized person.

The refrigerant leakage sensor shall be installed so its function can be verified easily.

The refrigerant leakage sensor shall be protected to prevent tampering or unauthorized resetting of the pre-set value.

To be effective, the refrigerant leakage sensor must be electrically powered at all times after installation, other than when servicing.

If the refrigerant leakage sensor detects a refrigerant leak, the fan will be turned on to the maximum, the compressor will stop running. You should immediately leave the leak area and notify a professional for handling.

The service life of the refrigerant sensor is 15 years, and it should be replaced after the service life or if the sensor is determined to be faulty during the service life.

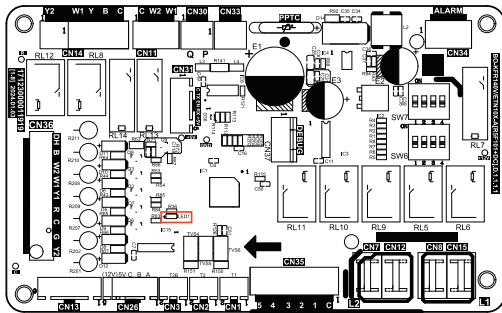

Fig. 3-5 Control Board LED

LED Status	Description
Steady ON	Normal Operation
OFF	Power Supply Failure
Steady Flashing	Dissipation Mode Active
3 Flash / Cycle	A2L Sensor Error
4 Flash / Cycle	A2L Sensor Communication Error
8 Flash / Cycle	A2L Sensor Over Service Life

Table 3-1 Control Board Test Functions

Ensure that the air handler is able to meet the minimum required dissipation mode airflows. These required minimum airflow rates during Dissipation Mode are listed in Table 3-5. They are based on the total system refrigerant charge quantity.

3.6 Refrigerant Charge and Room Area Limitations

In UL/CSA 60335-2-40, R454B refrigerant is classified as class A2L, which is mildly flammable. Therefore, R454B refrigerant is suitable for systems needing additional refrigerant charge and will limit the area of the rooms being served by the system.

Similarly, the total amount of refrigerant in the system shall be less than or equal to the allowable maximum refrigerant charge. The allowable maximum refrigerant charge depends on the area of the rooms being served by the system.

NOTICE

The abbreviations in this section are explained as follows:

m_c : The actual refrigerant charge in the system.
 A : the actual room area where the appliance is installed.

A_{min} : The required minimum room area.

m_{max} : The allowable maximum refrigerant charge in a room.

Q_{min} : The minimum circulation airflow.

ANv_{min} : The minimum opening area for connected rooms.

TA_{min} : The required minimum total area of the conditioned space (For appliances serving two or more rooms with an air dut system).

TA : The total area of the conditioned space connected by air ducts (For appliances serving two or more rooms with an air dut system).

3.6.1 The room area calculation requirements

⚠ CAUTION

The space considered shall be any space which contains refrigerant-containing parts or into which refrigerant could be released.

The room area (A) of the smallest, enclosed, occupied space shall be used in the determination of the refrigerant quantity limits.

For determination of room area (A) when used to calculate the refrigerant charge limit, the following shall apply.

The room area (A) shall be defined as the room area enclosed by the projection to the base of the walls, partitions and doors of the space in which the appliance is installed.

Spaces connected by only drop ceilings, ductwork, or similar connections shall not be considered a single space.

Units mounted higher than 70-55/64 inches and spaces divided by partition walls that are no higher than 62-63/64 inches shall be considered a single space.

Rooms on the same floor and connected by an open passageway between the spaces can be considered a single room when determining compliance to A_{min} , if the passageway complies with all of the following.

- 1) It is a permanent opening.
- 2) It extends to the floor.
- 3) It is intended for people to walk through.

The area of the connected rooms, on the same floor, connected by permanent opening in the walls and/or doors between occupied spaces, including gaps between the wall and the floor, can be considered a single room when determining compliance to A_{min} , provided all of the following conditions are met as Fig. 3-6.

1) Low level opening

- ①The opening shall not be less than Anv_{min} in Table 3-2.
- ②The area of any openings above 11-13/16 inches from the floor shall not be considered in determining compliance with Anv_{min} .
- ③At least 50 % of the opening area of Anv_{min} shall be below 7-7/8 inches from the floor.
- ④The bottom of the opening is not more than 3-15/16 inches from the floor.

- ⑤The opening is a permanent opening that cannot be closed.
- ⑥For openings extending to the floor the height shall not be less than 25/32 inches above the surface of the floor covering.

2) High level opening

- ①The opening shall not be less than 50 % of Anv_{min} in Table 3-2.
- ②The opening is a permanent opening that cannot be closed.
- ③The opening shall be at least 59 inches above the floor.
- ④The height of the opening is not less than 25/32 inches.

3) Room size requirement

- ①The room into which refrigerant can leak, plus the connected adjacent room(s) shall have a total area not less than A_{min} . A_{min} is shown in Table 3-4.
- ②The room area in which the unit is installed shall be not less than 20 % A_{min} . A_{min} is shown in Table 3-4.

NOTICE

The requirement for the second opening can be met by drop ceilings, ventilation ducts, or similar arrangements that provide an airflow path between the connected rooms.

The minimum opening for natural ventilation (Anv_{min}) in connected rooms is related to the room area (A), the actual refrigerant charge of refrigerant in the system (m_c), and the allowable MAXIMUM REFRIGERANT CHARGE in the system (m_{max}). Anv_{min} can be determined according to Table 3-2.

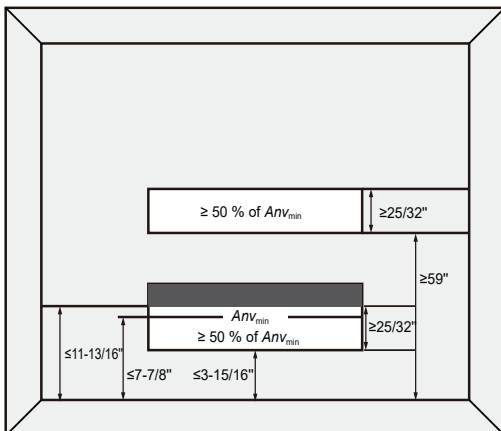

Fig.3-6 Opening Conditions for Connected Rooms

The minimum opening area for connected rooms

A		m_c		m_{max}		Anv_{min}	
ft ²	m ²	lb-oz	kg	lb-oz	kg	ft ²	m ²
100	10	17-3	7.8	6-10	3.0	1.3	0.13
110	11	17-3	7.8	7-5	3.3	1.2	0.12
120	12	17-3	7.8	8-0	3.6	1.1	0.11
130	13	17-3	7.8	8-10	3.9	1.0	0.10
140	14	17-3	7.8	9-5	4.2	1.0	0.10
150	14	17-3	7.8	10-0	4.5	0.9	0.09
160	15	17-3	7.8	10-10	4.8	0.8	0.08
170	16	17-3	7.8	11-5	5.1	0.7	0.07
180	17	17-3	7.8	12-0	5.4	0.6	0.06
190	18	17-3	7.8	12-10	5.7	0.5	0.05
200	19	17-3	7.8	13-5	6.0	0.5	0.05
210	20	17-3	7.8	14-0	6.3	0.4	0.04
220	21	17-3	7.8	14-10	6.6	0.3	0.03
230	22	17-3	7.8	15-5	6.9	0.2	0.02
240	23	17-3	7.8	16-0	7.2	0.1	0.01
250	24	17-3	7.8	16-10	7.5	0.1	0.01
260	25	17-3	7.8	17-5	7.8	0.0	0.00

Table 3-2

Note: Take the $m_c=17$ lb 3 oz as an example.

For appliances serving two or more rooms with an air duct system, The room area calculation shall be determined based on the total area of the conditioned space (TA) connected by ducts taking into consideration that the circulating airflow distributed to all the rooms by the appliance integral indoor fan will mix and dilute the leaking refrigerant before entering any room.

3.6.2. The allowed maximum refrigerant charge and required minimum room area

If the fan incorporated to an appliance is continuously operated or operation is initiated by a REFRIGERANT DETECTION SYSTEM with a sufficient CIRCULATION AIRFLOW rate, the allowable maximum refrigerant charge (m_{max}) and the required minimum room area (A_{min}/TA_{min}) is shown in Table 3-3 and Table 3-4.

The allowable maximum refrigerant charge

A/TA		m_{max}		A/TA		m_{max}	
ft ²	m ²	lb-oz	kg	ft ²	m ²	lb-oz	kg
30	3	2-0	0.9	150	14	10-0	4.5
40	4	2-10	1.2	160	15	10-10	4.8
50	5	3-5	1.5	170	16	11-5	5.1
60	6	4-0	1.8	180	17	12-0	5.4
70	7	4-10	2.1	190	18	12-10	5.7
80	8	5-5	2.4	200	19	13-5	6.0
90	9	6-0	2.7	210	20	14-0	6.3
100	10	6-10	3.0	220	21	14-10	6.6
110	11	7-5	3.3	230	22	15-5	6.9
120	12	8-0	3.6	240	23	16-0	7.2
130	13	8-10	3.9	250	24	16-10	7.5
140	14	9-5	4.2	260	25	17-5	7.8

Table 3-3

The required minimum room area

m_c		A_{min}/TA_{min}		m_c		A_{min}/TA_{min}	
lb-oz	kg	ft ²	m ²	lb-oz	kg	ft ²	m ²
2-2	1.0	33.1	3.1	10-2	4.6	152.1	14.2
2-9	1.2	39.7	3.7	10-9	4.8	158.7	14.8
3-0	1.4	46.3	4.4	11-0	5.0	165.3	15.4
3-7	1.6	52.9	5.0	11-7	5.2	171.9	16.0
3-15	1.8	59.5	5.6	11-14	5.4	178.5	16.6
4-6	2.0	66.1	6.2	12-5	5.6	185.1	17.2
4-13	2.2	72.7	6.8	12-12	5.8	191.7	17.9
5-4	2.4	79.3	7.4	13-3	6.0	198.4	18.5
5-11	2.6	86.0	8.0	13-10	6.2	205.0	19.1
6-2	2.8	92.6	8.7	14-1	6.4	211.6	19.7
6-9	3.0	99.2	9.3	14-8	6.6	218.2	20.3
7-0	3.2	105.8	9.9	14-15	6.8	224.8	20.9
7-7	3.4	112.4	10.5	15-6	7.0	231.4	21.5
7-15	3.6	119.0	11.1	15-14	7.2	238.0	22.2
8-6	3.8	125.6	11.7	16-5	7.4	244.6	22.8
8-13	4.0	132.2	12.3	16-12	7.6	251.2	23.4
9-4	4.2	138.8	12.9	17-3	7.8	257.9	24.0
9-11	4.4	145.5	13.6				

Table 3-4

The minimum circulation airflow

m_c		Q_{min}		m_c		Q_{min}	
lb-oz	kg	CFM	m ³ /h	lb-oz	kg	CFM	m ³ /h
2-2	1.0	59	100	10-2	4.6	275	467
2-9	1.2	71	121	10-9	4.8	287	488
3-0	1.4	83	141	11-0	5.0	298	506
3-7	1.6	95	161	11-7	5.2	310	527
3-15	1.8	107	182	11-14	5.4	322	547
4-6	2.0	119	202	12-5	5.6	334	567
4-13	2.2	131	223	12-12	5.8	346	588
5-4	2.4	143	243	13-3	6.0	358	608
5-11	2.6	155	263	13-10	6.2	370	629
6-2	2.8	167	284	14-1	6.4	382	649
6-9	3.0	179	304	14-8	6.6	394	669
7-0	3.2	191	325	14-15	6.8	406	690
7-7	3.4	203	345	15-6	7.0	418	710
7-15	3.6	215	365	15-14	7.2	430	731
8-6	3.8	227	386	16-5	7.4	442	751
8-13	4.0	239	406	16-12	7.6	454	771
9-4	4.2	251	426	17-3	7.8	466	792
9-11	4.4	263	447				

Table 3-5

If the altitude of installation is higher than 2000 ft, the required minimum room area follow as Table 3-6.

Charge lb	Altitude(ft)							
	2001-4000	4001-6000	6001-8000	8001-10000	10001-12000	12001-14000	14001-15000	above 15000
	Minimum Conditioned Space(ft ²)							
2	33	35	37	39	42	45	47	49
3	50	53	56	59	63	68	71	73
4	66	70	74	79	85	91	94	98
5	83	88	93	99	106	113	118	122
6	100	105	112	119	127	136	141	147
7	116	123	130	138	148	159	165	171
8	133	140	149	158	169	181	188	196
9	149	158	167	178	190	204	212	220
10	166	175	186	198	211	227	235	245
11	183	193	205	218	232	249	259	269
12	199	211	223	237	254	272	282	294
13	216	228	242	257	275	295	306	318
14	232	246	260	277	296	318	330	343
15	249	263	279	297	317	340	353	367
16	266	281	298	317	338	363	377	392
17	282	298	316	336	359	386	400	416
18	299	316	335	356	380	408	424	440
19	315	333	353	376	402	431	447	465
20	332	351	372	396	423	454	471	489

Table 3-6

CAUTION

The allowable maximum refrigerant charge of the Table 3-3 or the required minimum room area of the Table 3-4 is available only if the following conditions are met:

Minimum velocity of 3.28 ft/s, which is calculated as the indoor unit airflow divided by the nominal face area of the outlet. The grill area shall not be deducted.

Minimum airflow rate must meet the corresponding values in Table 3-5, which is related to the actual refrigerant charge of the system (m_c).

R454B refrigerant leakage sensor is configured.

NOTICE

The maximum refrigerant limit described above applies to unventilated areas. If adding additional measures, such as areas with mechanical ventilation or natural ventilation, The maximum refrigerant charge can be increased or the minimum room area can be reduced.

R454B refrigerant leakage sensor is configured for the indoor unit, meets the incorporated circulation airflow requirements, the maximum refrigerant charge or minimum room area can be determined according to Table 3-3 or Table 3-4.

⚠ CAUTION

If the actual room area, air outlet height, and refrigerant charge amount are not reflected in the above table, more severe cases need to be considered according to the data in the Table 3-2, 3-3, 3-4, 3-5.

- Installation scheme flow chart

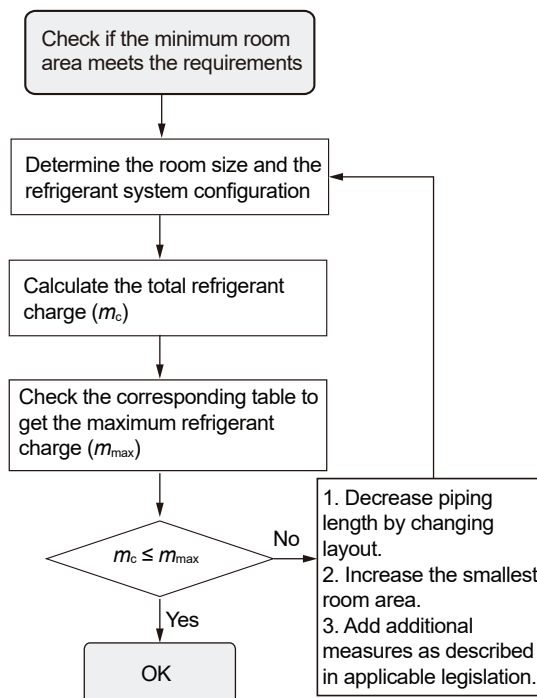

Fig.3-7

4 REFRIGERANT LINE

The suction pipe and liquid pipe of the indoor unit need to be protected and cannot be grabbed when moving the indoor unit.

Keep the coil connections sealed until refrigerant connections are made. See the Installation Instructions for the outdoor unit for details on line sizing, tubing installation, and charging information.

Coil is shipped with Nitrogen. Evacuate the system before charging with refrigerant.

Install refrigerant tubing so that it does not block service access to the front of the unit.

Nitrogen should flow through the refrigerant lines while brazing.

Use a brazing shield to protect the cabinet's paint and a wet rag to protect the rubber grommet and input pipe's TXV seal ring from being damaged by torch flames.

After the refrigerant connections are made, seal the gap around the connections with pressure sensitive gasket. The pipe-work including piping material, pipe routing, and installation shall include protection from physical damage in operation and service, and be in compliance with national and local codes and standards, such as ASHRAE 15, ASHRAE 15.2, IAPMO Uniform Mechanical Code, ICC International Mechanical Code, inspection prior to being covered or enclosed; or CSA B52. All field joints shall be accessible for inspection prior to being covered or enclosed.

All joints made in the installation between parts of the refrigerating system, with at least one part charged, shall be made in accordance with the following:

- A brazed, welded, or mechanical connection shall be made before opening the valves to permit refrigerant to flow between the refrigerating system parts. A vacuum valve shall be provided to evacuate the interconnecting pipe or any uncharged refrigerating system part.

- Mechanical connectors used indoors shall comply with ISO 14903. When mechanical connectors are reused indoors, sealing parts shall be renewed. When flared joints are reused indoors, the flare part shall be refabricated.

- Refrigerant tubing shall be protected or enclosed to avoid damage.

- Flexible refrigerant connectors (such as connecting lines between the indoor and outdoor unit) that may be displaced during normal operation shall be protected against mechanical damage.

Compliance is checked according to the installation instructions and a trial installation, if necessary.

Field-made refrigerant indoor joints shall be tightness tested. The test method shall have a sensitivity of 5 grams per year of refrigerant or better under a pressure of at least 0.25 times the maximum allowable pressure. No leak shall be detected.

After completion of field piping for split systems, the field pipework shall be pressure tested with an inert gas and then vacuum tested prior to refrigerant charging, according to the following requirements.

The minimum test pressure for the low side of the system shall be the low side design pressure and the minimum test pressure for the high side of the system shall be the high side design pressure, unless the high side of the system, cannot be isolated from the low side of the system in which case the entire system shall be pressure tested to the low side design pressure.

CAUTION

Use a wet rag to protect the two seal ring in the input pipe from being damaged by torch flames while brazing. (See Fig.4-1)

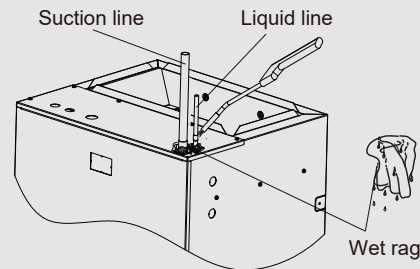

Fig.4-1 Piping connections

After the brazing work is finished, make sure to check if there is refrigerant leakage. After checking for vapor leaks, be sure to insulate the pipe connections referring to Fig.4-2.

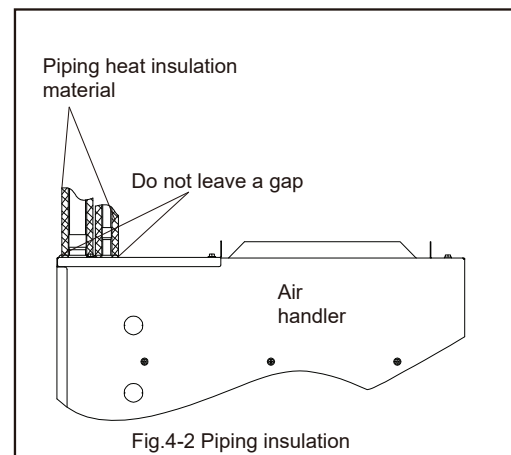

Fig.4-2 Piping insulation

NOTICE

It is recommended to install a filter drier, the filter drier should be installed in the liquid line between the outdoor unit's liquid line service valve and the indoor coil's metering device. The filter drier should be compatible with R454B refrigerant.

5. AIRFLOW PERFORMANCE

PSC Series

MODEL (SIZE, TON)	BLOWER SPEEDS	EXTERNAL STATIC PRESSURE (in H ₂ O)								
		0	0.1	0.2	0.3	0.4	0.5	0.6	0.7	0.8
18 (1-1/2)	Low	604	562	527	485	441	387	-	-	-
	Med	697	655	619	577	533	479	426	380	-
	High - Factory	802	761	721	682	637	592	541	481	408
24 (2)	Low	665	629	589	547	508	480	-	-	-
	Med	831	786	741	696	655	609	559	497	-
	High - Factory	932	881	833	786	742	689	636	574	515
30 (2-1/2)	Low	988	948	900	862	816	772	719	642	613
	Med - Factory	1197	1152	1097	1046	998	940	886	821	737
	High	1338	1284	1220	1159	1096	1029	960	879	792
36 (3)	Low	1118	1072	1018	971	920	876	819	759	693
	Med	1262	1213	1160	1098	1049	998	937	871	804
	High - Factory	1360	1311	1263	1229	1166	1074	1005	934	867

--- NOTES: Shaded boxes represent airflow outside the required 300-450 CFM/ton.

1. Airflow data is with no return grill. When using a return grill on 18 & 24 sizes, decrease numbers above by approx. 10 CFM. For 30 & 36 sizes, decrease numbers above by approx. 50 CFM

Table 5-1 PSC - Airflow Performance (Standard CFM)

ECM Series

MODEL (SIZE, TON)	BLOWER SPEEDS	EXTERNAL STATIC PRESSURE (in H ₂ O)								
		0	0.1	0.2	0.3	0.4	0.5	0.6	0.7	0.8
18 (1-1/2)	Tap (1)	584	541	487	441	416	357	359	299	253
	Tap (2)	662	615	582	542	514	467	427	385	351
	Tap (3) - Factory	710	683	645	619	579	535	490	458	416
	Tap (4)	803	769	742	710	675	642	609	572	534
	Tap (5)	899	871	836	810	789	758	719	689	646
24 (2)	Tap (1)	584	541	487	441	416	357	359	299	253
	Tap (2)	662	615	582	542	514	467	427	385	351
	Tap (3)	710	683	645	619	579	535	490	458	416
	Tap (4)	803	769	742	710	675	642	609	572	534
	Tap (5) - Factory	899	871	836	810	789	758	719	689	646
30 (2-1/2)	Tap (1)	1063	1012	936	898	853	823	780	740	701
	Tap (2)	1133	1080	1026	991	958	904	858	813	769
	Tap (3) - Factory	1220	1194	1111	1100	1060	1007	952	910	855
	Tap (4)	1234	1200	1146	1229	1088	1046	1004	951	917
	Tap (5)	1341	1310	1247	1225	1192	1151	1101	1077	1033
36 (3)	Tap (1)	1063	1012	936	898	853	823	780	740	701
	Tap (2)	1133	1080	1026	991	958	904	858	813	769
	Tap (3)	1220	1194	1111	1100	1060	1007	952	910	855
	Tap (4) - Factory	1234	1200	1146	1229	1088	1046	1004	951	917
	Tap (5)	1341	1310	1247	1225	1192	1151	1101	1077	1033

--- NOTES: Shaded boxes represent airflow outside the required 300-450 CFM/ton.

1. Airflow at 208 V is approximately the same as 230 V because the multi-tap ECM motor is a constant torque motor. The torque doesn't drop off at the speeds in which the motor operates.
2. Airflow is equivalent for front or bottom return configurations.

Table 5-2 ECM - Airflow Performance (Standard CFM)

6 DUCTWORK

Field ductwork must comply with the National Fire Protection Association NFPA 90A, NFPA 90B and any applicable local ordinance.

⚠ DANGER

Do not under any circumstances, connect return ductwork to any other heat producing device such as fireplace insert, stove, etc.

Unauthorized use of such devices may result in fire, carbon monoxide poisoning, explosion, personal injury or property damage.

Sheet metal ductwork in unconditioned spaces must be insulated and covered with a vapor barrier. Fibrous ductwork may be used if constructed and installed in accordance with SMACNA Construction Standard on Fibrous Glass Ducts. Ductwork must comply with National Fire Protection Association as tested by UL Standard 181 for Class I Air Ducts. Check local codes for requirements on ductwork and insulation.

- Duct system must be designed within the range of external static pressure the unit is designed to operate against. It is important that the system airflow be adequate. Make sure supply and return ductwork, grills, special filters, accessories, etc. are accounted for in total resistance. See airflow performance tables in this manual.
- Design the duct system in accordance with "ACCA" Manual "D" Design for Residential Winter and Summer Air Conditioning and Equipment Selection. Latest editions are available from: "ACCA" Air Conditioning Contractors of America, 1513 16th Street, N.W., Washington, D.C. 20036. If duct system incorporates flexible air duct, be sure pressure drop information (straight length plus all turns) shown in "ACCA" Manual "D" is accounted for in the system.
- Supply plenum is attached to the 3/4" duct flanges supplied with the unit. Attach flanges around the blower outlet.

IMPORTANT: If an elbow is included in the plenum close to the unit, it can not be smaller than the dimensions of the supply duct flange on the unit.

IMPORTANT: The front flange on the return duct if connected to the blower casing must not be screwed into the area where the power wiring is located. Drills or sharp screw points can damage insulation on wires located inside unit.

- Secure the supply and return ductwork to the unit flanges, using proper fasteners for the type of duct used and tape the duct-to-unit joint as required to prevent air leaks.

⚠ WARNING

If appliances connected via an air duct system to one or more rooms are installed in a room with an area less than shown in section 3.6 Table 3-3, that room shall be without continuously operating open flames (e.g. an operating gas appliance) or other potential ignition sources (for e.g. an operating electric heater, hot surfaces). A flame-producing device may be installed in the same space if the device is provided with an effective flame arrest.

For appliances connected via an air duct system to one or more rooms, auxiliary devices which may be a potential ignition source shall not be installed in the duct work. Examples of such potential ignition sources are hot surfaces with a temperature exceeding 700 °C and electric switching devices.

For appliances connected via an air duct system to one or more rooms, only auxiliary devices approved by the appliance manufacturer or declared suitable with the refrigerant shall be installed in connecting ductwork.

7 ABOUT THE AIR FILTER

7.1 Air Filter (Not Factory-Installed)

External filter or other means of filtration is required. Units should be sized for a maximum of 300 feet/min air velocity or what is recommended for the type of filter installed.

Filter application and placement are critical to airflow, which may affect the heating and cooling system performance. Reduced airflow can shorten the life of the system's major components, such as motor, limits, elements, heat relays, evaporator coil or compressor. Consequently, we recommend that the return air duct system have only one filter location. For systems with a return air filter grill or multiple filter grills, can have a filter installed at each of the return air openings.

If adding high efficiency filters or electronic air filtration systems, it is very important that the air flow is not reduced. If air flow is reduced the overall performance and efficiency of the unit will be reduced. It is strongly recommended that a professional installation technician is contacted to ensure installation of these such filtration systems are installed correctly.

IMPORTANT: Do not double filter the return air duct system. Do not filter the supply air duct system. This will change the performance of the unit and reduce airflow.

⚠ WARNING

Do not operate the system without filters. A portion of the dust entrained in the air may temporarily lodge in the duct and run at the supply registers. Any circulated dust particles could be heated and charred by contact with the air handler elements. This residue could soil ceilings, walls, drapes, carpets and other articles in the house.

Soot damage may occur with filters in place, when certain types of candles, oil lamps or standing pilots are burned.

7.2 Filter Installation Dimensions

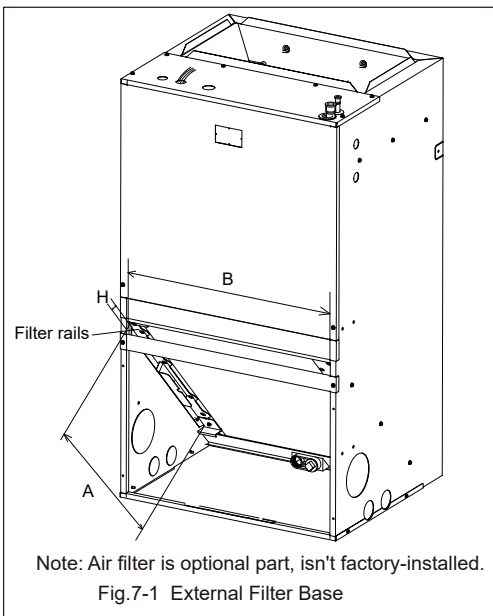

Care and Maintenance

For continuing high performance and to minimize possible equipment failure, it is essential that periodic maintenance be performed on this equipment. The only required maintenance that may be performed by the consumer is filter maintenance. See Table 7-1.

Unit Size	Filter Size in (mm)	"A" in (mm)	"B" in (mm)	"H" in (mm)
18, 24	NOMINAL 16 x 20 x 1 (406 x 508 x 25)	15.5 (394)	19.6 (498)	0.9 (23)
30, 36	NOMINAL 20 x 20 x 1 (508 x 508 x 25)	20.2 (513)	20.3 (516)	

Table 7-1 Filter Sizes

The minimum maintenance requirements for this equipment are as follows:

1. Inspect and clean or replace air filter each month or as required.
2. Inspect cooling coil, drain pan, and condensate drain each cooling season for cleanliness. Clean as necessary.
3. Inspect blower motor and wheel for cleanliness each heating and cooling season. Clean as necessary.
4. Inspect electrical connections for tightness and controls for proper operation each heating and cooling season. Service as necessary.

NOTICE

The installing technician should explain system operation to the consumer with particular emphasis on indoor fan coil operation sounds and filter maintenance. The filter must meet the requirements of UL900.

AIR FILTER REMOVAL

1. Remove bolts manually, remove air filter recover. See in Fig.7-1.
2. Hold the edge of the air filter and extract out.
3. Clean the air filter (Vacuum cleaner or pure water may be used to clean the air filter. If the dust accumulation is too heavy, use soft brush and mild detergent to clean it and dry out in cool place).
4. Install new filter so that the arrow on the filter is in the same direction as airflow.

8 DRAIN PIPE INSTALLATION

Consult local codes for specific requirements.

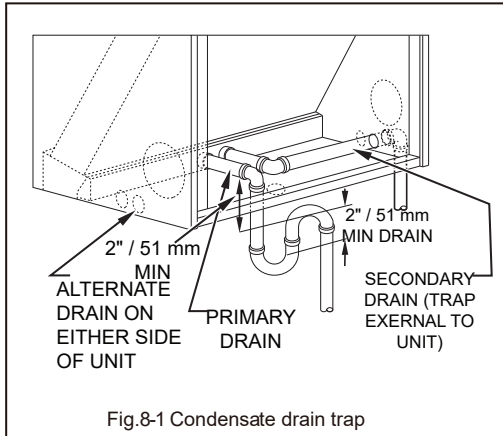

IMPORTANT:

1. When making drain fitting connections to the drain pan, use a thin layer of Teflon paste, silicone or Teflon tape and install, hand tighten.
2. When making drain fitting connections to drain pan, do not overtighten. Over tightening fittings can split pipe connections on the drain pan.

- Install drain lines so they do not block service access to front of the unit. Minimum clearance of 24 inches is required for filter, coil or blower removal and service access.
 - Do not reduce drain line size less than connection size provided on condensate drain pan. Use 3/4" PVC piping for drain piping connections.
 - Do not connect condensate drain line to a closed or open sewer pipe. Run condensate to an open drain or run line to a safe outdoor area.
 - Make provisions for disconnecting and cleaning of the primary drain line should it become necessary. Install a 3 inch trap in the primary drain line as close to the unit as possible. Make sure that the top of the trap is below the connection to the drain pan to allow complete drainage of pan (See Fig. 8-1).
 - All drain lines must be pitched downward away from the unit a minimum of 1/8" per foot of line to ensure proper drainage.
 - Make sure unit is level or pitched slightly toward primary drain connection so that water will drain completely from the pan. Up to an additional 1/4" rise over the width or depth of the unit is allowed to create additional sloping towards the drain. Unit must be positioned between level and 1/4" rise, sloping toward the drain connections. See Fig.8-2, Fig.8-3, Fig.8-4, Fig.8-5.
 - Plug the unused drain connection with the plugs provided in the parts bag, using a thin layer of teflon paste, silicone or teflon tape to form a water tight seal.
 - Test condensate drain pan and drain line after installation is complete. Pour water into drain pan, enough to fill drain trap and line. Check to make sure drain pan is draining completely, no leaks are found in drain line fittings, and water is draining from the termination of the primary drain line.
- Auxiliary drain line should be run to a place where it will be noticeable if it becomes operational. Homeowner should be warned that a problem exists if water should begin running from the auxiliary drain line.
 - The drain line should be insulated where necessary to prevent sweating and damage due to condensate forming on the outside surface of the line.
 - Be sure to insulate the drain piping and drain socket since condensation may cause water leakage.
 - Be sure to install a drain trap at the drain outlet since the inside of the unit is at negative pressure relative to atmospheric pressure during operation.

9 ELECTRICAL WIRING

In the U.S.A., wiring must conform with current local codes and the current National Electric Code (NEC). In Canada, wiring must conform with current local codes and the current Canadian Electrical Code (CEC).

⚠ DANGER

Installation and servicing of air conditioning equipment can be hazardous due to internal refrigerant pressure and live electrical components. Only trained and qualified service personnel should install or service this equipment. Installation and service performed by unqualified persons can result in property damage, personal injury, or death.

Risk of electrical shock. Disconnect all remote power supplies before installing or servicing any portion of the system. Failure to disconnect power supplies can result in property damage, personal injury, or death.

PSC motor Schematic

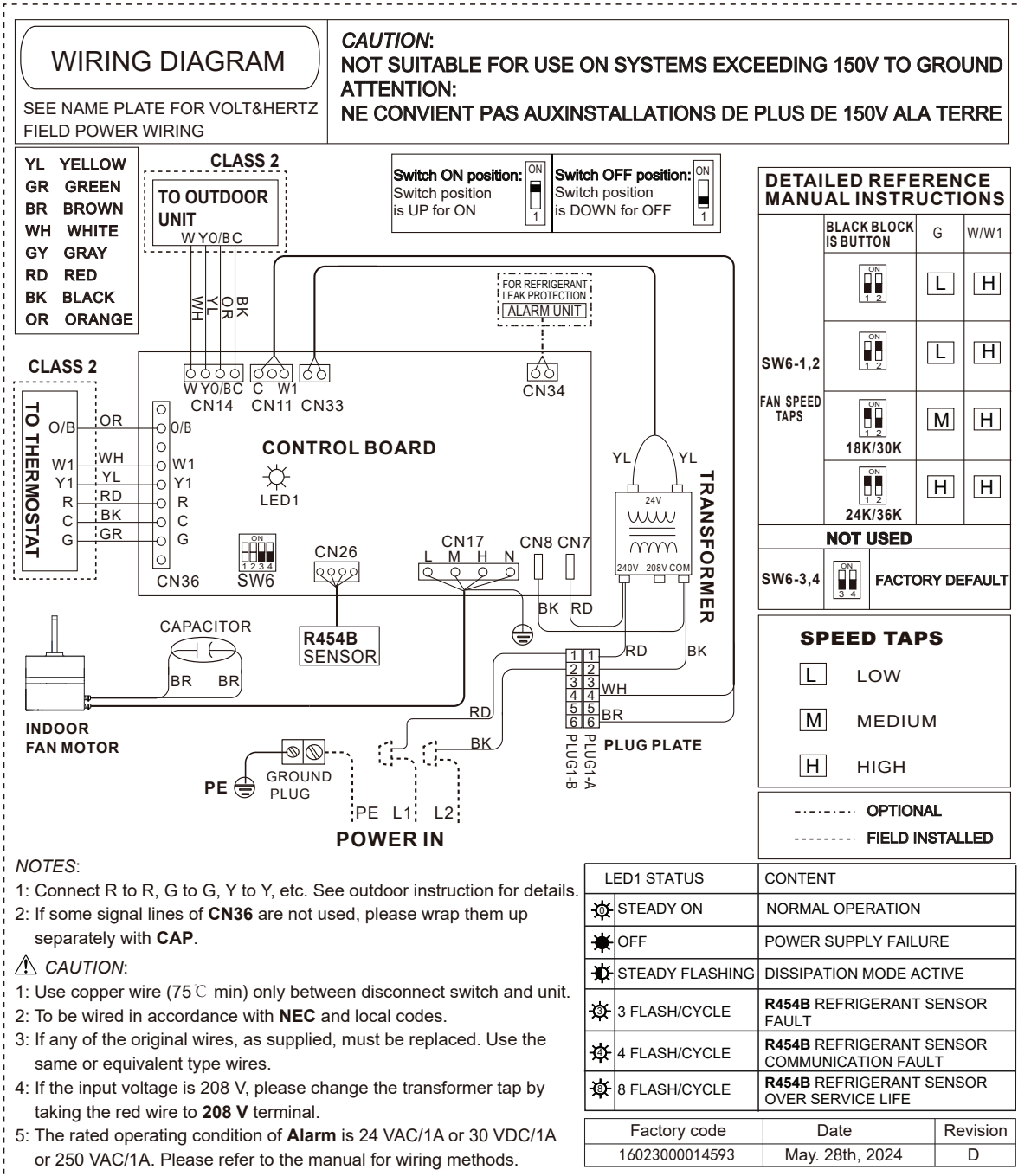

ECM motor Schematic

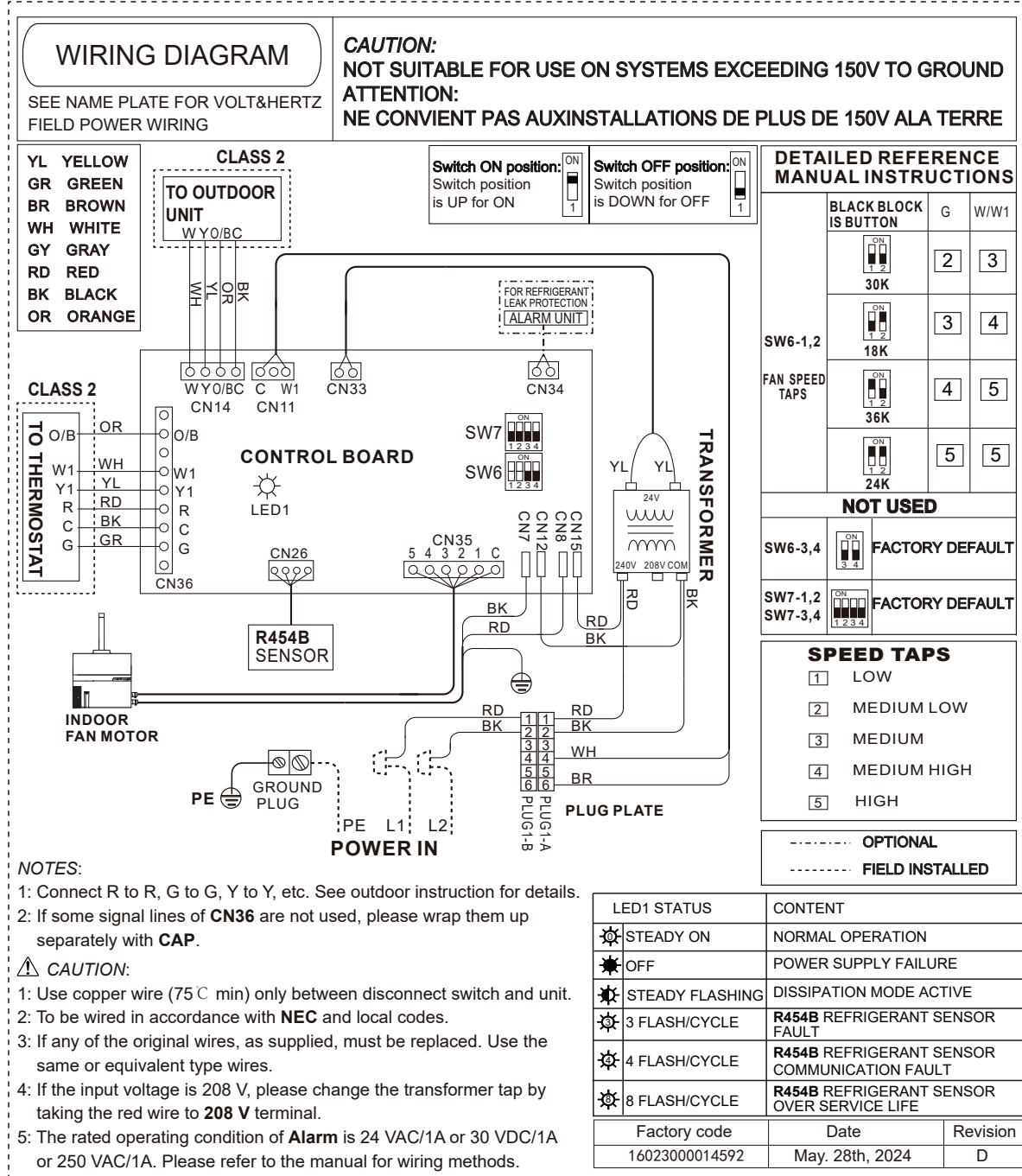

9.1 Control Wiring

CAUTION

Conventional 24VAC non-communicating thermostat control wires must be connected reliably and protected by insulation.

The wires unused should be insulated, and the copper wires should not be exposed.

Sharp metal edges can cause injury. When installing the unit, use care to avoid sharp edges.

Avoid sharp metal edges for wires to prevent wear, or it may lead to short circuit or electric leakage and cause danger.

NOTICE

Electrostatic discharge can affect electronic components. Take care during unit installation and service to protect the unit's electronic controls. Precautions will help to avoid control exposure to electrostatic discharge by putting the unit, the control and the technician at the same electrostatic potential. Touch hand and all tools on an unpainted unit surface before performing any service procedure to neutralize electrostatic charge.

Low voltage control connections are made to low voltage pigtailed extending from top of air handler (upflow position - see Fig 2-1).

Do not connect the power cords (high voltage) to the Conventional 24VAC non-communicating thermostat control wires (low voltage), otherwise it will damage the control board.

Conventional 24VAC non-communicating thermostat control wires should be fixed well. Otherwise, the connectors may be loose or the terminal may be damaged when they are pulled.

Power cords and conventional 24VAC non-communicating thermostat control wires must be separated from each other with a distance of more than 2 inches. Otherwise, the communication may be abnormal.

The conventional 24VAC non-communicating thermostat control wires connectors are SELV connection points.

9.1.1 Low voltage wires maximum length

Table 9-1 defines the maximum total length of low voltage wires from the outdoor unit to the indoor unit and the indoor unit to the thermostat.

Conventional 24VAC Non-communicating Control Wires	
Low Voltage Wires Size	Max Wires Length
18 AWG	150 ft.
16 AWG	225 ft.

Table 9-1

NOTICE

Before proceeding with electrical connections, make certain that voltage, frequency, and phase correspond to that specified on rating plate. Also, check to be sure that the service provided by utility is sufficient to handle additional load imposed by this equipment.

Refer to unit wiring label for proper field high- and low-voltage wiring. Make all electrical connections in accordance with NEC and any local codes or ordinances that might apply.

Please connect the wire following the wiring diagram. The rating power of the transformer is limited. If you connect some additional loads/parts such as zoning panel to it, it may cause component damage. Consult with a professional service person when connecting additional loads/parts to transformer.

All units shipped from factory are wired for 240VAC transformer operation. If the input voltage is 208 V, please change the transformer tap by taking the red wire to 208VAC terminal.

9.1.2 Low voltage wires connections

Low-voltage wire connections include the indoor unit connecting to the outdoor unit and the indoor unit connecting to the thermostat.

1. Remove the electrical control box panel.

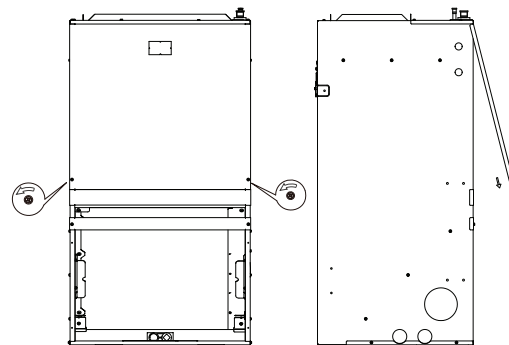

Fig.9-1

2. Wires connections diagram.

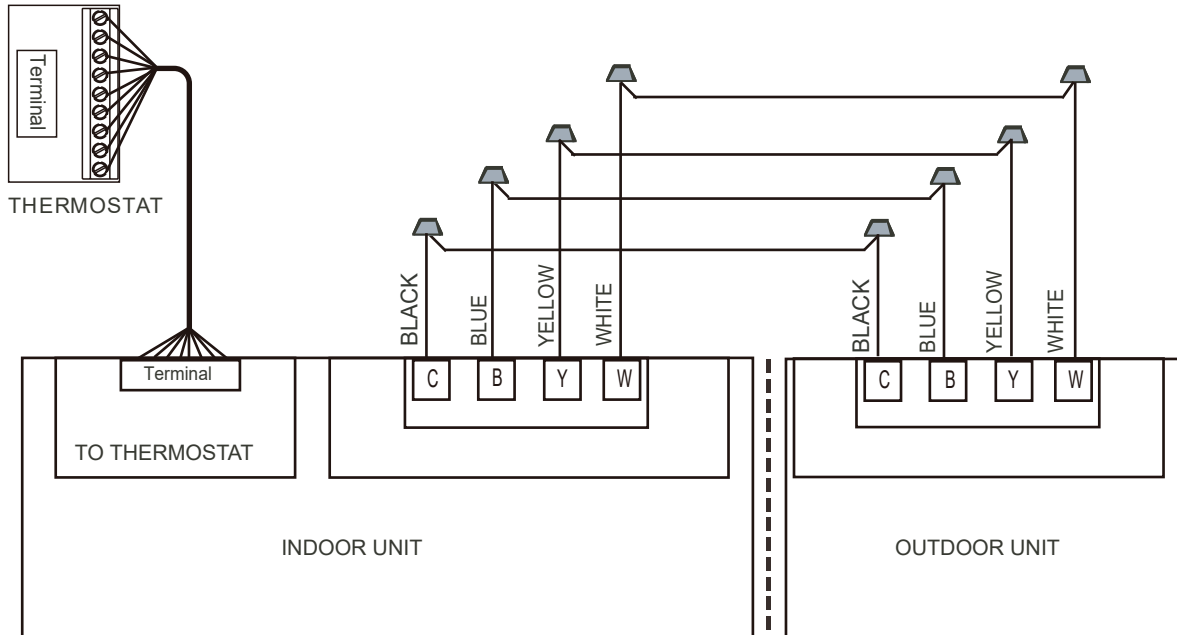

Fig.9-2

3. Low voltage wires connections with outdoor unit.

- Connect the conventional 24VAC non-communicating thermostat control wires (C, B, Y and W) to the four field supplied wires.

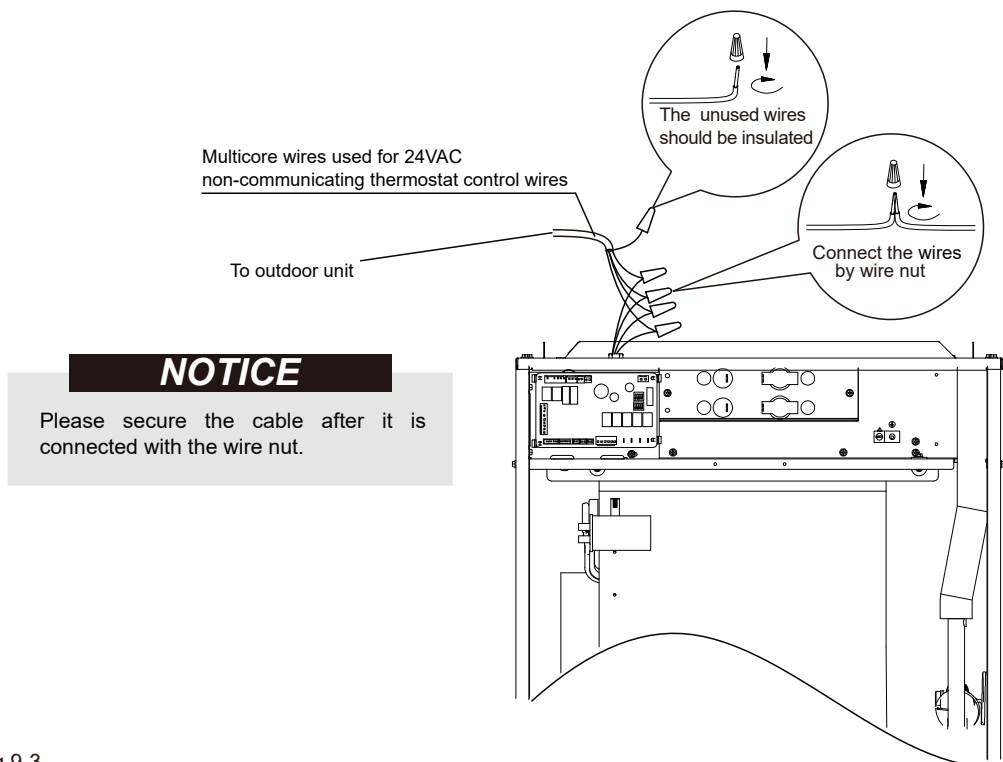

Fig.9-3

4. Low voltage wires connections with thermostat.

4.1 Connect the Control communication cables by wire nut.

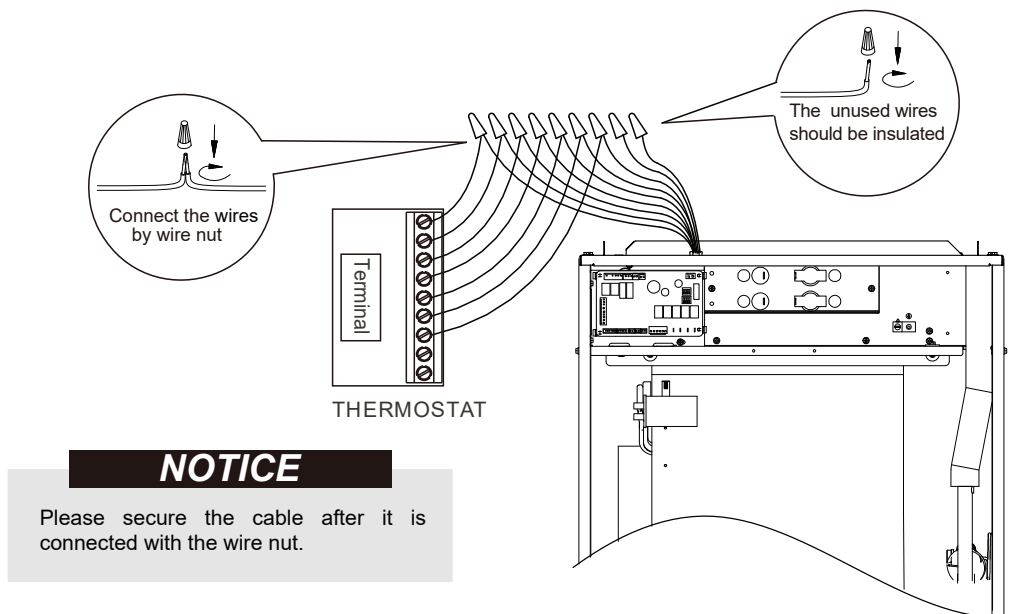

Fig.9-4

4.2 Wiring diagram of the thermostat.

Fan

Thermostat closes R to G. G energizes and completes circuit to indoor blower motor. When G is de-energized, there is a 90 second blower off-delay.

Cooling Mode

Thermostat energizes R to G, and R to Y. G energizes and completes indoor blower motor. Y energizes outdoor unit. When cooling call is satisfied, G is de-energized, and there is a 90-second blower-off delay.

Heat Pump Heating Mode

Thermostat energizes R to G and R to Y and R to O/B (heat pump only) G energizes and completes circuit to indoor blower motor. Y energizes outdoor unit (O/B is energized for heat pump). When heating call is satisfied, G is de-energized, and there is a 90-second blower-off delay.

Heat Pump Heating with Auxiliary Electric Heat

Thermostat energizes R to G, R to Y, and R to W1. G energizes and completes circuit to indoor blower motor. W1 energizes electric heat relay(s) which completes circuit to heater element(s). When W1 is de-energized, electric heat relay(s) open, turning off heater elements. When G is de-energized there is a 90 s blower off-delay.

Electric Heat or Emergency Heat Mode

Thermostat energizes R to W1. W1 energizes electric heat relay(s) which completes circuit to heater element(s). Blower motor is energized through normally closed contacts on fan relay. When W1 is de-energized, electric heat relay(s) opens, the ECM motor will have blower off-delay based on motor speed tap selection.

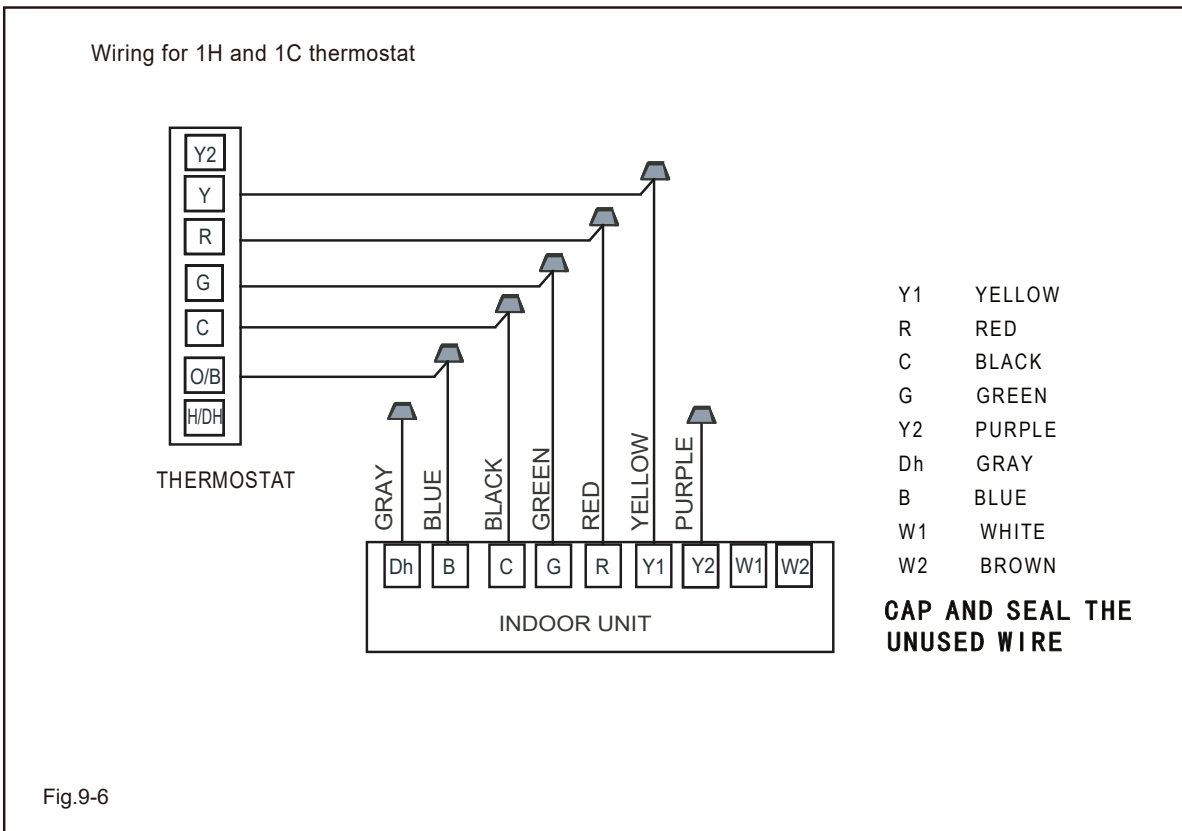
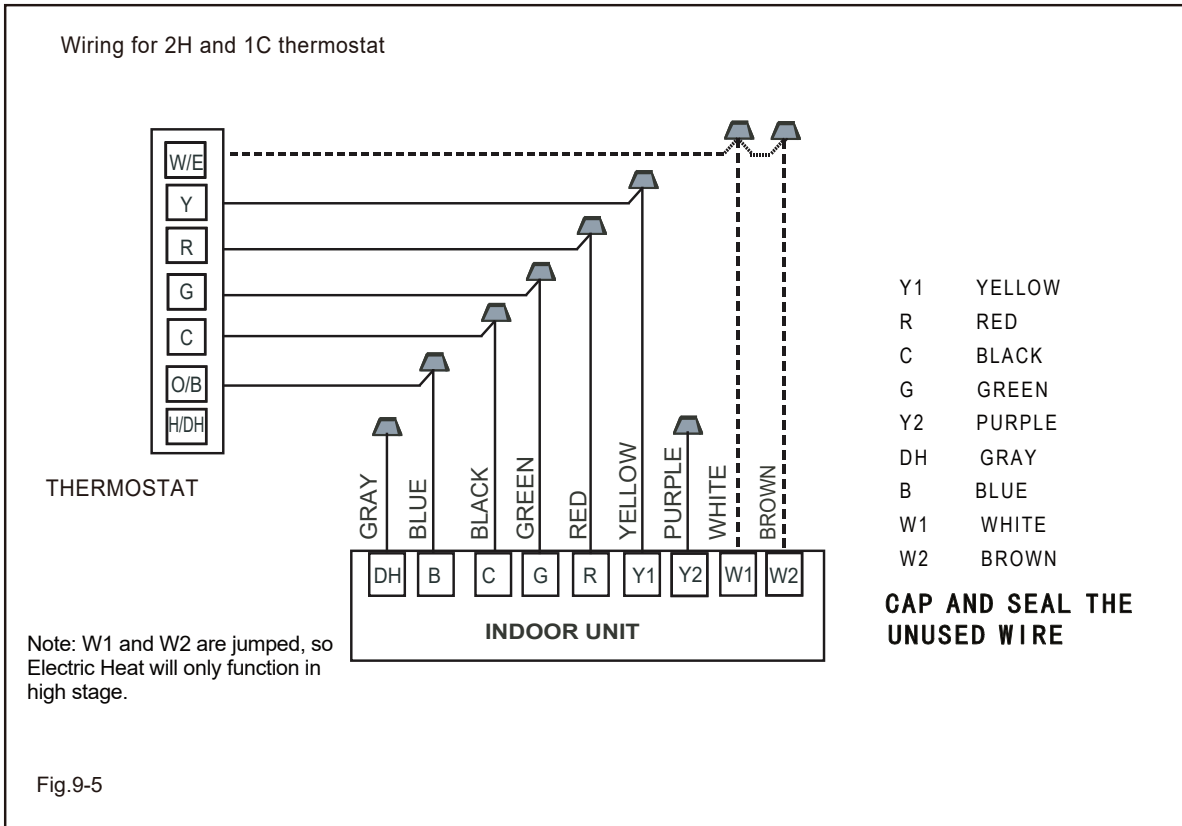

9.2 Power Wiring

Refer to unit wiring instructions for recommended wiring procedures. Use No. 18 AWG color-coded, insulated (35 °C minimum) wire to make low-voltage connections between thermostat and unit. If thermostat is located more than 100 feet (30 m) from unit as measured along low-voltage wire, use No. 16 AWG color-coded, insulated (35 °C minimum) wire.

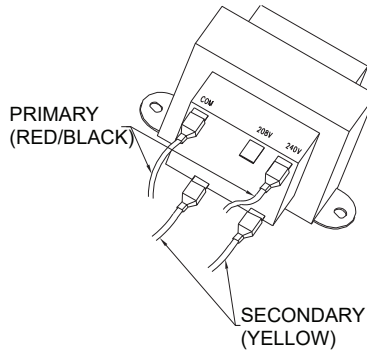

Fig. 9-7 Transformer Connections

NOTICE

Before proceeding with electrical connections, make certain that voltage, frequency, and phase correspond to that specified on rating plate. Also, check to be sure that the service provided by utility is sufficient to handle additional load imposed by this equipment.

Refer to unit wiring label for proper field high- and low-voltage wiring. Make all electrical connections in accordance with NEC and any local codes or ordinances that might apply. Unit must have a separate branch electrical circuit.

NOTICE

All units are shipped from factory wired for 240 VAC transformer operation. For 208 VAC operation, move primary lead from 240 VAC terminal to 208 VAC terminal.

For maximum ampacity and over-current protection, see unit rating plate or product data sheet.

1. Provide power supply for unit being installed in accordance with unit wiring diagram and rating plate.
2. Connect line-voltage leads to the harness pigtail or the heat-kit circuit breaker. Use copper wire only.
3. Use UL listed conduit and conduit connector for connecting line-voltage leads to unit and obtaining proper ground. If conduit connection uses reducing washers, a separate ground wire must be used. Grounding can also be accomplished by using the ground lug provided in the control box. Power wiring may be connected to either the right or left sides or top of unit. Knockouts of 7/8" (22 mm) dia. are provided for connection of power wiring to unit. Some heater sizes may require a conduit larger than the 7/8" opening; in this situation the high-voltage connection opening should be enlarged to fit the conduit. When removing the knockouts for electrical connections, an opening in the insulation should be cut to fit the opening.

The cut edge of the insulation should be reinforced with foil tape to prevent fraying. The foil facing and insulation shall not be removed beyond the knockout opening size.

4. Install plastic grommet packed with unit in hole for low-voltage wires.

In the U.S.A., wiring must conform with current local codes and the current National Electric Code (NEC). In Canada, wiring must conform with current local codes and the current Canadian Electrical Code (CEC).

⚠ WARNING

Installation and servicing of air conditioning equipment can be hazardous due to internal refrigerant pressure and live electrical components. Only trained and qualified service personnel should install or service this equipment. Installation and service performed by unqualified persons can result in property damage, personal injury, or death.

Risk of electrical shock. Disconnect all remote power supplies before installing or servicing any portion of the system. Failure to disconnect power supplies can result in property damage, personal injury, or death.

Fire Hazard. Use of aluminum wire with this product may result in a fire, causing property damage, severe injury or death. Use copper wire only with this product.

Can cause injury or death. Unit must be properly grounded in accordance with national and local codes.

Natural grounding poles embedded in the ground can be used, but do not connect the ground wire to the following locations:

- (a) Pipes of flammable or explosive gases, which may otherwise lead to an explosion or fire.
- (b) Insulated plastic pipes, otherwise there is no grounding effect.
- (c) Telephone line or lightning rod, otherwise it will be dangerous for increasing the ground potential during lightning strikes.

During installation, testing, servicing, and troubleshooting of this product, it may be necessary to work with live electrical components. Failure to follow all electrical safety precautions when exposed to live electrical components could result in death or serious injury.

⚠ CAUTION

Sharp metal edges can cause injury. When installing the unit, use care to avoid sharp edges.

Avoid sharp metal edges for wires to prevent wear, or it may lead to short circuit or electric leakage and cause danger.

Wires should be fixed well. Otherwise, the connectors may be loose or the terminal may be damaged when they are pulled.

NOTICE

Electrostatic discharge can affect electronic components. Take care during unit installation and service to protect the unit's electronic controls. Precautions will help to avoid control exposure to electrostatic discharge by putting the unit, the control and the technician at the same electrostatic potential. Touch hand and all tools on an unpainted unit surface before performing any service procedure to neutralize electrostatic charge.

Do not add phase junction capacitors, otherwise it may cause serious damage to the product.

Do not start the unit before installing pipes. Otherwise, the compressor will be damaged.

9.2.1 High Voltage Power Supply

Ensure that the supply voltage to the unit is not more than 10 % over the rated voltage or 10 % under the rated voltage.

9.2.2 Power Wires Sizes, Disconnect Switch and Breaker

Refer to the unit nameplate for minimum circuit ampacity, and maximum fuse or circuit breaker (HACR TYPE per NEC). Install power cords and properly sized disconnect switch and breaker.

9.2.3 Power Wires Connections

Power wiring may be connected to either the right, side or top. Three 7/8", 1-3/8", 1-3/4" dia. concentric knock-outs are provided for connection of power wiring to unit.

Power wires by splicing follow as Fig.9-8.

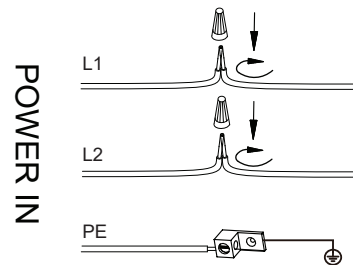

Fig.9-8

Ground lug(s) are located close to wire entrance on right side of unit (up-flow). Connect the ground wire from the power supply to the unit ground lug connection. as Fig. 9-8.

⚠ WARNING

The unit must be permanently grounded. Failure to do so can result in electrical shock causing personal injury or death.

9.3 Alarm Wiring

9.3.1 Wiring Diagram

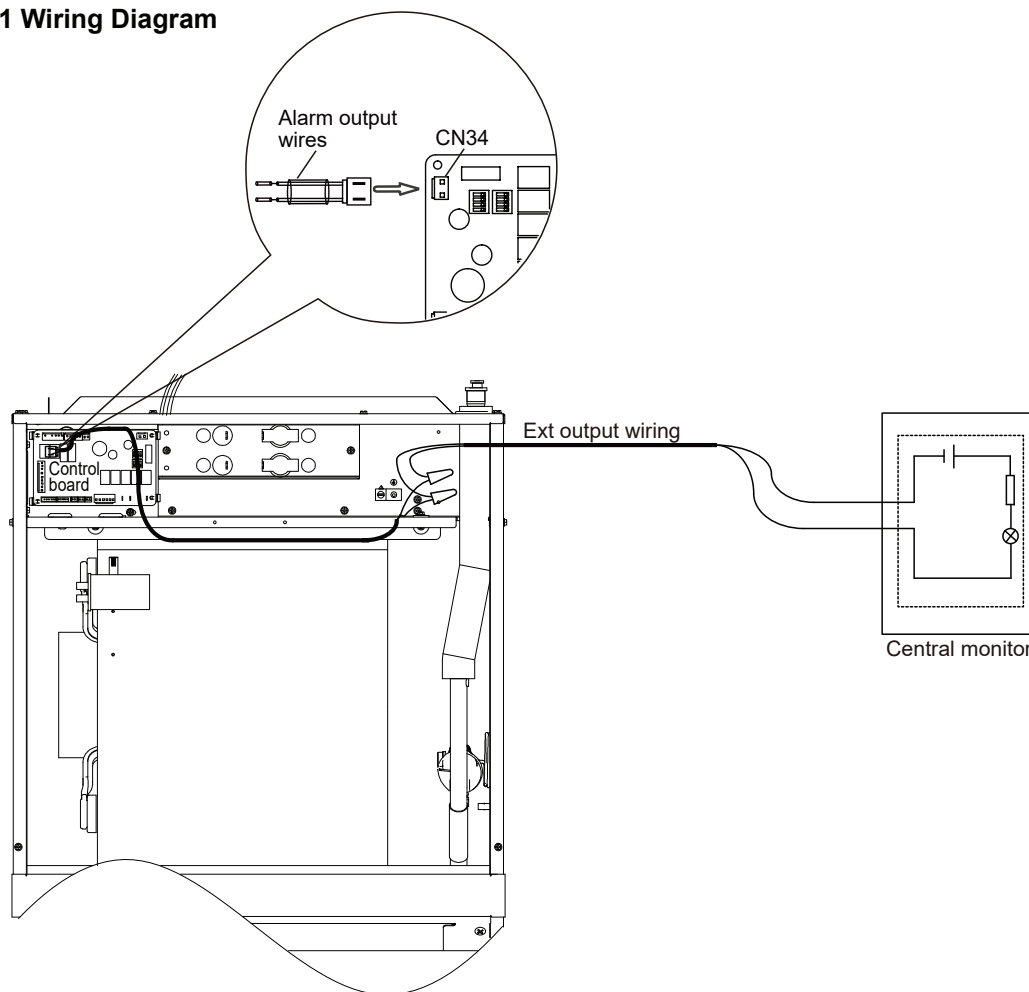

Fig.9-9

Note:

The remote control of the internal circuit is for reference only, the user can change the wiring mode according to the actual situation.

The Alarm port is a switch that closes when the refrigerant leakage protection is triggered. The user can choose the appropriate remote.

9.3.2 Installation

Step 1 : Take out the Alarm wires from the accessory bag and plug it into CN34 on the control board (see Fig.9-9).

Step 2 : Connect the Alarm wires with the central monitor (see Fig.9-9).

⚠ CAUTION

The rated operating condition of ALARM is 24 VAC/1A or 30 VDC/1A or 250 VAC/1A.

The type of wiring for ext output should use cables of AWG 18 (Min. AWG 18).

9.4 Electric Heater Kit

9.4.1 Electric heater kit breaker information

NO.	Kit	Description	Breaker	Model
1	EHK2-05B	5 kW heater	Max. 240 V, 30 A, 2 P	18,24,30,36
2	EHK2-08B	7.5 kW heater	Max. 240 V, 50 A, 2 P	18,24,30,36
3	EHK2-10B	10 kW heater	Max. 240 V, 60 A, 2 P	18,24,30,36

Table 9-2

9.4.2 Electric heater kits installation information

Requirements

Installation of electric heat sections must conform with standard in National Fire Protection Association (NFPA) Standard for Installation of Air Conditioning and Ventilation Systems NFPA No. 90A, Standard for the Installation of Residence Type Warm Air Heating and Air Conditioning System NFPA No. 90B, manufacturer’s installation instructions and local municipal building codes. Heaters are approved for clearance to combustible materials as listed on heater rating plate. Accessibility and service clearances must take precedence over fire protection clearances. All wiring must conform with local codes and the National Electric Code (NEC). ANSI-C1-1978.

⚠ CAUTION

As with any mechanical equipment, contact with sharp sheet metal edges can result in personal injury. Take care while handling this equipment and wear gloves and protective clothing.
The circuit breaker of electric heater kit in indoor unit cannot be used as air switch for power cables and cannot be operated by users. Maintenance personnel need to disconnect the main switch before servicing.

Installation

⚠ WARNING

Supply circuit power wiring must be 167 °F (75 °C) minimum copper conductors only. See Table 9-3 for Electrical Data in this section for ampacity, wire size and circuit protector requirement. Supply circuit protective devices may be either fuses or “HACR” type circuit breakers.

NOTICE

Install the electric heater before installing the air outlet duct system.

Finished view (for reference only).

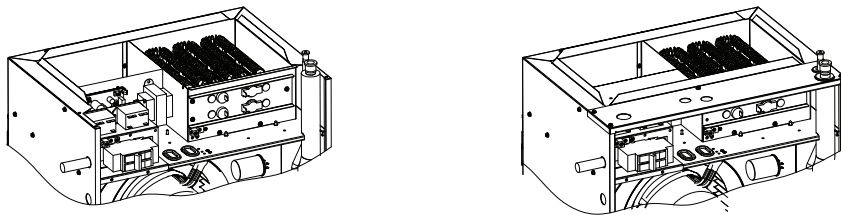

Fig.9-10

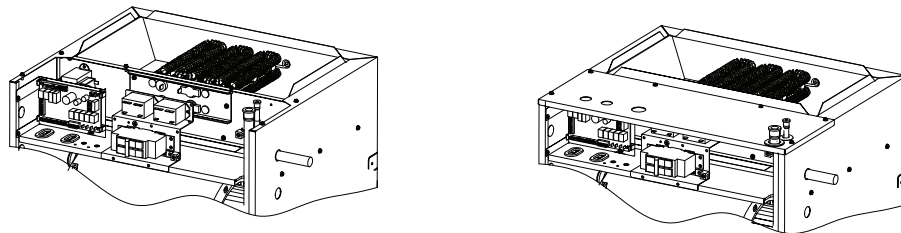

Fig.9-11

Please refer to the manual of electric heater kit for detailed installation and wiring instructions.

9.4.2 Electric Heater Kit Electrical Data

PSC Series

Heater Kit Model Used	Model	Electric Heater (kW)	Min. Circuit Ampacity		Max. Fuse or Breaker (HACR) Ampacity		Fan Speed		
			240 V	208 V	240 V	208 V	Low	Medium	High
EHK2-05B	18	5	27.0	23.7	30	30	●	●	●
EHK2-08B		7.5	40.2	35.0	50	50	●	●	●
EHK2-10B		10	53.3	46.3	60	60	●	●	●
EHK2-05B	24	5	27.7	24.2	30	30	●	●	●
EHK2-08B		7.5	40.7	35.5	50	50	●	●	●
EHK2-10B		10	53.8	46.8	60	60	●	●	●
EHK2-05B	30	5	28.8	25.4	30	30	●	●	●
EHK2-08B		7.5	41.9	36.7	50	50	●	●	●
EHK2-10B		10	54.9	47.9	60	60	●	●	●
EHK2-05B	36	5	28.6	25.1	30	30	●	●	●
EHK2-08B		7.5	41.6	36.4	50	50	●	●	●
EHK2-10B		10	54.6	47.7	60	60	●	●	●

Table 9-3

ECM Series

Heater Kit Model Used	Model	Electric Heater (kW)	Min. Circuit Ampacity		Max. Fuse or Breaker (HACR) Ampacity		Fan Speed				
			240 V	208 V	240 V	208 V	1	2	3	4	5
EHK2-05B	18	5	28.4	24.9	30	30	●	●	●	●	●
EHK2-08B		7.5	41.4	36.2	50	50	●	●	●	●	●
EHK2-10B		10	54.5	47.5	60	60	●	●	●	●	●
EHK2-05B	24	5	28.4	24.9	30	30	●	●	●	●	●
EHK2-08B		7.5	41.4	36.2	50	50	●	●	●	●	●
EHK2-10B		10	54.5	47.5	60	60	●	●	●	●	●
EHK2-05B	30	5	29.4	25.9	30	30	●	●	●	●	●
EHK2-08B		7.5	42.4	37.2	50	50	●	●	●	●	●
EHK2-10B		10	55.5	48.5	60	60	●	●	●	●	●
EHK2-05B	36	5	29.4	25.9	30	30	●	●	●	●	●
EHK2-08B		7.5	42.4	37.2	50	50	●	●	●	●	●
EHK2-10B		10	55.5	48.5	60	60	●	●	●	●	●

Table 9-4

NOTICE

Heat pump systems require a specified airflow. Each ton of cooling requires between 350 and 450 cubic feet of air per minute (CFM), or 400 CFM nominally.

10 Dip Switch Settings

Check whether the DIP switch is correct according to the wiring nameplate after the electrical wiring is complete. SW6-1,2 is used to set the blower motor speed. The factory default settings of different models as shown in the Table 10-1 and Table 10-2. The DIP switch can be adjusted according to different speed requirements. When there is a G signal, the blower motor runs at a lower speed. When there is W/W1 signal, it runs at a high speed.

PSC series

The dip switches on the PSC series units are located in the lower left portion of the control board. (SW6)

- PSC 18 K (1.5 Ton), dip switch 1 is set to ON, switch 2 is set to ON.
- PSC 24 K (2 Ton), dip switch 1 is set to ON, switch 2 is set to ON.
- PSC 30 K (2.5 Ton), dip switch 1 is set to ON, switch 2 is set to OFF.
- PSC 36 K (3 Ton), dip switch 1 is set to ON, switch 2 is set to ON.
- SW6 dip switches 3 and 4 are not used and should remain set to OFF.

To change the fan speed on model PSC series, refer to Fig. 10-1.







	Black Block is Button	G	W/W1
SW6-1,2 Fan Speed Taps		L	H
		L	H
	 30K	M	H
	 18K/24K/30K	H	H
SW6-3		0 s off-delay	
		90 s off-delay (factory default)	
Not Used			
SW6-4		Factory default	

Table 10-1 PSC Series Schematic

ECM Series

The dip switches for the ECM series units are the lower of the two sets of 4 dip switches located in the upper right area of the control board. (SW6)

- ECM 18 K (1.5 Ton), dip switch 1 is set to OFF, switch 2 is set to ON.
- ECM 24 K (2 Ton), dip switch 1 is set to ON, switch 2 is set to ON.
- ECM 30 K (2.5 Ton), dip switch 1 is set to OFF, switch 2 is set to ON.
- ECM 36 K (3 Ton), dip switch 1 is set to ON, switch 2 is set to OFF.
- SW6 dip switches 3 and 4 are not used and should remain set to OFF.
- SW7 dip switches are not used and should remain set to OFF.

To change the fan speed on model ECM Series, refer to Fig. 10-2.







	Black Block is Button	G	W/W1
SW6-1,2 Fan Speed Taps		2	3
	 18K/30K	3	4
	 36K	4	5
	 24K	5	5
Not Used			
SW6-3,4		Factory default	
SW7-1,2 SW7-3,4		Factory default	

Table 10-2 ECM Series Schematic

11 SERVICE

11.1 Error Code and Troubleshooting

The unit LED will flash when the unit is abnormal. Security consideration, the outdoor unit shutdown until the abnormal condition is corrected except.

Error Code Description

NO.	LED1 Status	Description
1	3Flash/Cycle	R454B refrigerant sensor fault
2	4Flash/Cycle	R454B refrigerant sensor communication fault
3	Keep Flashing	R454B refrigerant leakage protection in indoor unit
4	8Flash/Cycle	R454B refrigerant sensor over service life

Table 11-1

Troubleshooting

NO.	LED1 Status	Possible Reason
1	3Flash/Cycle	R454B refrigerant sensor failure
2	4Flash/Cycle	Wiring error/ R454B refrigerant sensor failure
3	Keep Flashing	R454B refrigerant leakage/ R454B refrigerant sensor failure
4	8Flash/Cycle	R454B refrigerant sensor over service life/R454B refrigerant sensor failure

Table 11-2

NOTICE

The flash interval is 2 seconds. For example, 3 Flash / Cycle is flash three times every 2 seconds.

CAUTION

If the refrigerant sensor is over its service life, it should be replaced by an authorized person.
 If a leak is detected, follow safety procedures: Immediately evacuate all persons from the room or space, and contact the qualified licensed service personnel to advise them that a refrigerant R454B (A2L class flammable refrigerant) leak has occurred.

11.2 Piston Installation

This coil comes with a factory installed piston metering device. See Table 11-3 for factory installed piston size. Some system combinations will require a different sized piston to be field installed.

MODEL	47	52	58	60	64
18	X*				
24		X*			
30			X*		
36					X*

* means that this piston is pre-installed

Table 11-3

12 DISPOSAL

Comply with national regulations. Components and accessories from the units are not part of ordinary domestic waste. Complete units , compressors, motors etc. are only to be disposed of via qualified disposal specialists. This unit uses flammable refrigerant R454B. Please contact the dealer when you want to dispose of this unit. Law requires that the collection, transportation and disposal of refrigerants must conform with the regulations governing the collection and destruction of hydrofluorocarbons.

Page Intentionally Left Blank

Page Intentionally Left Blank



SE SERIES LIMITED WARRANTY

Congratulations on purchasing your new HVAC equipment.

Your unit automatically qualifies for the warranty coverage listed below provided you meet the warranty conditions.

YEAR 1 PRODUCT REPLACEMENT

If the heat exchanger, evaporator coil (packaged systems only), condenser coil, or compressor fails within the first year (365 days) after the date of installation to the original consumer for the original installation, the original purchase cost of the unit will be reimbursed to the authorized Comfort-Aire/Century distributor who has received prior authorization from Comfort-Aire/Century for the failure. The owner is responsible for additional labor, freight, and miscellaneous charges. Units installed in a commercial application, defined as any application other than a residential/multifamily (personal, family or household) purpose, are not eligible for the one year product replacement.

LIMITED WARRANTY

All parts are warranted to be free from defects in workmanship and materials for normal residential use and maintenance for five (5) years from the date of purchase by the original consumer for the original residential installation. The compressor and the heat exchanger are warranted to be free from defects in workmanship and materials for normal residential use and maintenance for ten (10) years from the date of purchase by the original consumer for the original residential installation.

LIMITED EXTENDED WARRANTY

When registered with Comfort-Aire/Century, the heat exchanger is warranted to be free from defects in material and workmanship for twenty (20) years and all parts are warranted to be free from defects in material and workmanship for ten (10) years from the date of purchase by the original consumer for the original installation.

DURATION OF WARRANTY

The warranty begins on the date of purchase by the original consumer (homeowner). The original consumer must retain a receipted bill of sale or invoice showing model and serial number as proof of the warranty period initiation.

CONDITIONS FOR WARRANTY COVERAGE

Unit must be properly installed and maintained by a licensed HVAC service provider in accordance with the installation, operation, and maintenance instructions provided with each unit. Unit cannot have been subjected to accident, alteration, improper repair, neglect/misuse, or force majeure. Proof of proper maintenance over the lifetime of the unit must be supplied. Performance cannot be impaired by use of any product not authorized by Comfort-Aire/Century, or by any adjustments or adaptations to components. Serial numbers and/or rating plate have not been altered or removed. Damage has not been a result of inadequate wiring or voltage conditions, use during brown-out conditions, or circuit interruptions. Unit remains in the original residential installation and is not transferrable. Unit was not purchased over the internet or at auction. Non-approved refrigerant and/or non-approved system additives will void this warranty.

WARRANTY EXCEPTIONS

The Limited Express Warranty does not cover costs associated with normal maintenance, utility usage, labor, shipping and handling, or collateral damage. It also does not cover any portion or component of the system that is not supplied by Comfort-Aire/Century, regardless of the cause of failure of such portion or component.

LIMITATION OF LIABILITY

There are no other express or implied warranties. Comfort-Aire/Century makes no warranty of merchantability and does not warrant that the unit is suitable for any particular purpose, building, room size, or condition except as specifically provided in this document. There are no other warranties, express or implied, which extend beyond the description in this document. All warranties implied by law are limited in duration to the five-year term of the Parts Warranty. Your exclusive remedy is limited to the replacement of defective parts. Comfort-Aire/Century will not be liable for any consequential or incidental damages caused by any defect in this unit. This warranty gives you specific legal rights and you may also have other rights which vary from state to state. Some states do not allow a limitation on how long an implied warranty lasts or do not allow the exclusion or limitation of incidental or consequential damages, so the above limitations or exclusions may not apply to you. No warranties are made for units sold outside the continental United States and Canada. Your distributor or final seller may provide a warranty on units sold outside these areas. Comfort-Aire/Century will not be liable for damages if our performance regarding warranty resolution is delayed by events beyond our control including accident, alteration, abuse, war, government restrictions, strikes, fire, flood, or force majeure.



Please visit www.heatcontroller.com
to register your new product.

KEEP THIS INFORMATION AS A RECORD OF YOUR PURCHASE

Apply Serial Number and Model Number sticker here (from product carton). If unavailable, write serial number and model number below (can be found on unit rating plate).

Date of Purchase _____ Date Installation Completed _____

Component of new HVAC system Replacement furnace only

Remember to retain your bill of sale as proof of warranty period and ownership.

Due to ongoing product improvements, specifications and dimensions are subject to change and correction without notice or incurring obligations. Determining the application and suitability for use of any product is the responsibility of the installer. Additionally, the installer is responsible for verifying dimensional data on the actual product prior to beginning any installation preparations.

Incentive and rebate programs have precise requirements as to product performance and certification. All products meet applicable regulations in effect on date of manufacture; however, certifications are not necessarily granted for the life of a product. Therefore, it is the responsibility of the applicant to determine whether a specific model qualifies for these incentive/rebate programs.



1900 Wellworth Avenue • Jackson, MI 49203 • 517-787-2100