



RESIDENTIAL
ME PREMIER SERIES

PRODUCT CATALOG

Part#: RP3005 | Revised: March 25, 2026

Models: ME 024-072
60Hz - R-454B



Table of Contents

Models:
ME
024-072

3	Introduction	29	Corrections
5	Features, Options, and Accessories	29	Part Load Performance Tables
6	Intelligent Communicating Controls	30	Full Load Performance Tables
7	Internal Variable Water Flow Control	31	Antifreeze Table
9	Selection Procedure	33	Water Pressure Drop Table
11	Model Nomenclature	34	Physical Data
12	Performance Data	35	Dimensional Data
12	AHRI/ASHRAE/ISO 13256-1	35	Standard Dimensional Tables
14	Selection Notes	39	Horizontal
25	CV EC Motor Limits	40	Horizontal Service Access
26	Electrical Data	41	Vertical Upflow
28	High Head and Standard Variable Pump Performance	43	Vertical Service Access
		44	Minimum Installation Area
		45	Accessories and Options
		46	Revision History

THE ME PREMIER SERIES

The ME Premier Series showcases superb efficiency ratings, quiet operation, and application flexibility that is synonymous with our products. The ME surpasses ASHRAE 90.1 efficiency standards and utilizes R-454B low Global Warming Potential (GWP) refrigerant, setting a high standard for eco-friendly performance. The ME is Energy Star certified due to its innovative and environmentally conscious design.

Available in sizes 2 tons (7.0 kW) through 6 tons (21.1 kW) with multiple cabinet options (vertical upflow, vertical downflow, and horizontal) the ME offers a wide range of units for most any installation. The ME has an extended range refrigerant circuit, capable of ground-loop (geothermal) applications as well as open-loop applications. Some of the features of the innovative ME series include: ultra-efficient two-stage unloading scroll compressor (024-072), EC constant volume fan motor, microprocessor controls, galvanized steel cabinet construction, corrosive-resistant stainless-steel drain pan, and acoustic type fiber insulation.

Recent EPA mandates require an industry transition to low-GWP refrigerants, such as R-454B which is a gas that is classified as having low-toxicity, low-flammability rating. Due to these characteristics, R-454B systems charged with over 62 ounces of refrigerant must contain an integrated Refrigerant Detection System (RDS). In the unlikely event of a system-refrigerant leak, the RDS shuts down compressor operation and runs the unit blower motor to disperse any concentration of leaked refrigerant in compliance with UL 60335-2-40 safety standards. For ME products, only the 5- and 6-ton sizes (060 and 072) are required to have the RDS and the feature is optional on all other sizes.

Our double-isolation compressor mounting system makes the ME one of the quietest units on the market. Compressors are mounted using specially engineered sound-tested EPDM grommets to a heavy gauge mounting plate, which is then isolated from the cabinet base with EPDM grommets to minimize vibration transmission and maximize sound attenuation. Multiple removable access panels and an easily accessible control box make installation and maintenance user friendly. Options such as coated air coil, internal variable-speed pump, and modulating water valve allow for customizable design solutions.

Intelligent communicating controls provide technicians an interface into the operation of the system in real time without the need for hard tooling. On-board advanced controls communicate the key operating system temperatures allowing technicians to startup, commission, and service equipment remotely by smart phone or website interface. Communication can also be established at the unit via a communicating thermostat or Wireless Service Tool. Intelligent controls monitor current performance, facilitate system adjustments, and capture operating conditions at time of fault. Data and controls are presented in a user-friendly format for a convenient service experience.

Variable Water Flow represents a major advancement in water flow system management efficiency. Variable Water Flow not only builds major water circulation components into the unit for a clean installation, it also intelligently varies water flow to minimize pump energy consumption and improve system reliability.

The heart of Variable Water Flow is either a variable-speed pump (for ground loops) or modulating water valve (for ground water or central variable-speed pumps) intelligently controlled with DXM2.6 Advanced Communicating Controls. Water flow is automatically varied based on changes in unit capacity level (stage) and source water temperature to maintain optimum system performance. Variable Water Flow allows the use of direct return piping, while eliminating external two-way valves and automatic flow regulators, making Variable Water Flow systems inherently self-balancing.

Variable Water Flow systems provide reduced water pumping power compared to traditional fixed-speed pumping systems. They also protect the unit against extreme operating conditions, extending the life of the compressor. Since Variable Water Flow is built into the unit, it also saves on installation time and makes for a clean and compact installation. The ME Series water-source heat pumps are designed to meet the challenges of today's HVAC demands with one of the most innovative products available on the market.

FEATURES

- Sizes 024 (2 ton, 7.0 kW) through 072 (6 tons, 21.1 kW)
- Exceeds ASHRAE 90.1 efficiency standards
- Environmentally-friendly R-454B low-GWP refrigerant
- Refrigerant Detection System (RDS) (mandatory on sizes 060 and 072, optional feature for sizes 024-048)
- Intelligent variable speed Constant Volume (CV) EC blower motors for precise airflow control and soft-start feature
- Part-load operation significantly lowers annual operating costs (sizes 024-072)
- Galvanized-steel cabinet construction with matte black polyester powder coated finish and stainless-steel access panels
- Sound-absorbing glass-fiber insulation
- Unique double-isolation compressor mounting with vibration isolation for quieter operation
- Insulated divider and separate compressor/air-handler compartments
- TXV metering device
- Field-convertible supply-air arrangement (horizontal configurations only)
- Unit Performance Sentinel performance-monitoring system
- Eight standard safety features
- Easy-to-clean rust-prohibitive stainless-steel drain pans
- DXM2.6 Advanced Communicating Controls:
 - Connect directly to the system with a Wireless Service Tool
 - Provides real-time unit operating conditions
 - Reduces startup, commissioning, and service time by providing key system temperatures electronically
 - Captures operating conditions in the event of a safety shutdown

- Anti-short cycle and over/under-voltage protection
- Easy-access control box
- High-pressure, loss-of-charge, and condensate-overflow protection
- LED fault and status indication at controller
- Tin-plated air coils for added protection from formicary corrosion (060-072)
- Aluminum Microchannel air coils for added protection and improved efficiency (024-048)
- Extended-range insulation for geothermal applications
- Return-air filter frames for 2-inch MERV 11 filter

OPTIONS

- Corrosion-resistant cupronickel water-heat exchanger
- Domestic Hot Water Generator (HWG)
- Variable Water Flow unit-integrated variable-speed water pump
- Variable Water Flow unit-integrated modulating water valve for maximum water-flow control (replaces traditional motorized water valve and autoflow regulator)
- Factory-installed compressor soft starter to reduce inrush currents for more efficient startups
- Integrated power disconnect

ACCESSORIES

- Wide variety of thermostat options to meet your application needs
- Auxiliary electric heaters

AN INFORMATION GATEWAY TO MONITOR, CONTROL, AND DIAGNOSE YOUR SYSTEM

Our communicating water-source heat pump offers an information gateway into the system. This allows users to interact with their system in clear language, delivering improved reliability and efficiency by monitoring and controlling the system. This makes our water-source heat pumps easy to install and service.

Monitor/Configure – Installers can configure the following from the Wireless Service Tool: unit family, size, accessory configuration, and demand reduction (optional, to limit unit operation during peak times). Users can look up the current system status: temperature sensor readings and operational status of the blower.

Precise Control – DXM2.6 Exclusive - Intelligent, 2-way communication between the DXM2.6 and smart components like the variable CFM constant volume CV EC blower motor. The DXM2.6 uses information received from the smart components and sensors to precisely control unit operation to deliver higher efficiency, reliability and increased comfort.

Diagnostics – While in Service Mode, technicians can access fault description, possible causes and most importantly, the conditions (temp, flow, i/o conditions, configuration) at the time of the fault. Manual Operation mode allows technicians to manually command operation for any of the thermostat outputs, blower speed, to help troubleshoot specific components.

With communicating controls, technicians have a gateway to system information never before available to our water-source heat pump products.

DXM2.6

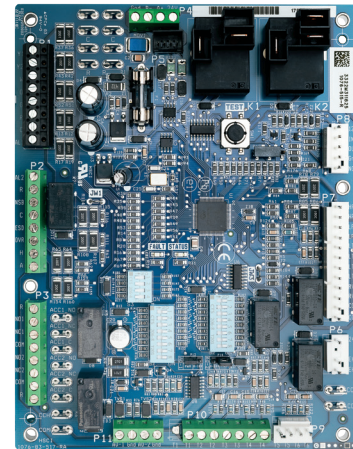

Wireless Service Tool Web Application

Devices	
Unit - Primary	▼
Settings	>
Diagnostics	>
Fault History	▼
Fault History 1	
Fault History 2	
Fault History 3	
Fault History 4	
Fault History 5	
Reporting	>
System Flow	>
Manual Operation	
Thermostat	▼
Settings	>
Refrigerant Detection System	▼
Diagnostics	>
Tool Configuration	
Logging	

Fault Code	Low air coil pressure
Operating Mode	Cooling Stage 2
Entry Date	9/12/2024 4:31:00 PM
Water Coil Liquid Temperature	92.2 F
Air Coil Liquid Temperature	50.1 F
Entering Water Temperature	95.2 F
Leaving Water Temperature (Source)	103.2 F
Compressor Discharge Temperature	195 F
Control Voltage	24.8 V
Cool Setpoint Temperature	73 F
Dehumidification Setpoint	65 %
Heat Setpoint Temperature	71 F

Heat Controller works continually to improve its products. As a result, the design and specifications of each product at the time of order may be changed without notice and may not be as described herein. Please contact Heat Controller's Customer Service Department at 517-787-2100 for specific information on the current design and specifications. Statements and other information contained herein are not express warranties and do not form the basis of any bargain between the parties, but are merely Heat Controller's opinion or commendation of its products. The latest version of this document is available at www.heatcontroller.com. Engineered and assembled in the USA. © Heat Controller, Inc. All Rights Reserved 2024

INTERNAL VARIABLE WATER FLOW

Industry-first, built-in Variable Water Flow replaces a traditionally inefficient, external component of the system (water circulation) with an ultra-high-efficient, variable-speed, internal water-flow system. This saves 70-80% on water circulation compared to traditional single-speed pump systems. Multi-unit installations are also much simpler with Variable Water Flow systems, as the units automatically adjust water flow across the system.

Intelligent Controls facilitate communication between the Wireless Service Tool, DXM2.6, sensors, and internal water pump/valve to make true variable water flow a reality.

VARIATIONS

- **Low System Pressure Drop Modulating Valve:**
High CV motorized valve for central pumping. (Standard unit).
- **High System Pressure Drop Modulating Valve:**
Motorized valve for higher-pressure water systems, such as water well pumps (optional).
- **Standard Head Variable Pump:**
Multi-unit/central pumping (optional).
- **High Head Variable Pump:**
Multi-/individual-unit pumping (optional).

BENEFITS

- Easier and quicker unit installation as the flow control is built in to the unit.
- Superior reliability by varying the water flow to deliver more stable operation.
- Increased cost savings by varying the flow (and pump watt consumption) to match the unit's mode of operation.

INTERNAL COMPONENTS

All our water source heat pumps can be installed more easily and compactly than their predecessors because Variable Water Flow components are internal to the unit. They also save installing contractors labor and time by eliminating the need for an external flow regulator or a bulky external pumping module.

VARIABLE FLOW

Variable Water Flow technology enables variable water flow through the unit, with the DXM2.6 adjusting the pump speed to maintain an installer-set loop ΔT . By controlling the water flow, the system is able to operate at its optimal capacity and efficiency. Variable Water Flow provides a lower flow rate for part load where units typically operate 80% of the time and a higher, more normal flow rate for full-load operation.

The variable-speed pump or motorized modulating valve delivers variable water flow, controlled by DXM2.6, based on loop water ΔT .



ENERGY SAVINGS WITH WATER CIRCULATION CONTROL

Units with Variable Water Flow deliver greater operating cost savings by varying the water flow to match the unit's operation (ex: lower water flow when unit is in part-load operation). Lowering the flow results in lower energy consumption by the water pump (=greater cost savings) in Variable Water Flow units (whether internal or external pump).

In applications using Variable Water Flow with internal variable-speed electronically commuted (EC) pump, the EC pump uses fewer watts than a fixed-speed (PSC) pump even at full load. The EC pump excels in energy savings in part load, saving 70-80% watts compared to fixed-speed pumps (see chart). The EC pump can operate with independent flow rates for both heating and cooling operations allowing for more energy savings.

In loop applications, when the motorized modulating valve slows down the water flow during part-load operation, the external pump consumes fewer watts and saves more energy.

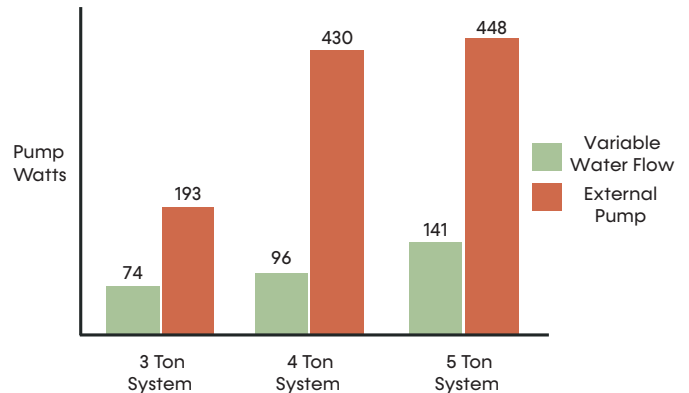

Reference Calculations

Heating	Cooling
$LWT = EWT - \frac{HE}{GPM \times \text{Constant}}$	$LWT = EWT + \frac{HR}{GPM \times \text{Constant}} \quad LC = TC - SC$
$LAT = EAT + \frac{HC}{CFM \times 1.08}$	$LAT (DB) = EAT (DB) - \frac{SC}{CFM \times 1.08} \quad S/T = \frac{SC}{TC}$

Constant = 500 for water, 485 for antifreeze

Conversion Table - to convert inch-pound (English) to S-I (Metric)

Airflow	Water Flow	External Static Pressure	Water Pressure Drop
Airflow (L/s) = CFM x 0.472	Water Flow (L/s) = GPM x 0.0631	ESP (Pa) = ESP (in of wg) x 249	PD (kPa) = PD (ft of hd) x 2.99

Legend and Glossary of Abbreviations

Abbreviations	Descriptions
Btuh	Btu (British Thermal Unit) per hour
BMS	Building Management System
CDT	Compressor discharge temperature, °F
CFM	Airflow, cubic feet per minute
COP	Coefficient of performance = Btuh output/Btuh input
CT EC	Electronically commutated constant torque blower motor
CV EC	Electronically commutated constant volume blower motor
DB	Dry bulb temperature, °F
DT or Delta T	Temperature Differential
EAT	Entering air temperature, °F
EER	Energy efficient ratio = Btuh output/Watt input
ESP	External static pressure, inches w.g.
EWT	Entering water temperature, °F
FPT	Female pipe thread
GPM	Water flow in U.S., gallons per minute
HC	Air heating capacity, Btuh
HE	Total heat of extraction, Btuh
HGRH	Hot Gas Reheat
HR	Total heat of rejection, Btuh

Abbreviations	Descriptions
HWG	Hot water generator (desuperheater) capacity, MBtuh
kW	Total power unit input, kilowatts
LAT	Leaving air temperature, °F
LC	Latent cooling capacity, Btuh
LOC	Loss of charge
LWT	Leaving water temperature, °F
LLWT	Load Leaving Water Temperature, °F
MBtuh	1,000 Btu per hour
MPT	Male pipe thread
MWV	Motorized water valve
PSC	Permanent split capacitor
RDS	Refrigerant Detection System
SC	Sensible cooling capacity, Btuh
SLWT	Source Leaving Water Temperature, °F
S/T	Sensible to total cooling ratio
TC	Total cooling capacity, Btuh
VFD	Variable frequency drive
WB	Wet bulb temperature, °F
WPD	Waterside pressure drop, psi or feet of head
WSE	Waterside economizer

Heat Controller works continually to improve its products. As a result, the design and specifications of each product at the time of order may be changed without notice and may not be as described herein. Please contact Heat Controller's Customer Service Department at 517-787-2100 for specific information on the current design and specifications. Statements and other information contained herein are not express warranties and do not form the basis of any bargain between the parties, but are merely Heat Controller's opinion or commendation of its products. The latest version of this document is available at www.heatcontroller.com. Engineered and assembled in the USA. © Heat Controller, Inc. All Rights Reserved 2024

Selection Procedure

USE THE FOLLOWING SELECTION STEPS

1. Determine the actual heating and cooling loads at the desired dry bulb and wet bulb conditions.
2. Obtain the following design parameters: Entering water temperature, water flow rate in GPM, airflow in CFM, water flow pressure drop and design wet and dry bulb temperatures. Airflow CFM should be between 300 and 450 CFM per ton. Unit water pressure drop should be kept as close as possible to each other to make water balancing easier. Go to the appropriate tables and find the proper indicated water flow and water temperature.
3. Select a unit based on total and sensible cooling conditions. Select a unit which is closest to, but no larger than, the actual cooling load.
4. Enter tables at the design water flow and water temperature. Read the total and sensible cooling capacities.

Note: interpolation is permissible, extrapolation is not.

5. Read the heating capacity. If it exceeds the design criteria it is acceptable. It is quite normal for water-source heat pumps to be selected on cooling capacity only since the heating output is usually greater than the cooling capacity.
6. Determine the correction factors associated with the variable factors of dry bulb and wet bulb.

Corrected Total Cooling =
tabulated total cooling x wet bulb correction.

Corrected Sensible Cooling =
tabulated sensible cooling x wet/dry bulb correction.

7. Compare the corrected capacities to the load requirements. Normally if the capacities are within 10% of the loads, the equipment is acceptable. It is better to undersize than oversize, as undersizing improves humidity control, reduces sound levels and extends the life of the equipment.
8. When completed, calculate water temperature rise and assess the selection. If the units selected are not within 10% of the load calculations, then review what effect changing the GPM, water temperature and/or air flow and air temperature would have on the corrected capacities. If the desired capacity cannot be achieved, select the next larger or smaller unit and repeat the procedure. Remember, when in doubt, undersize slightly for best performance.

EXAMPLE EQUIPMENT SELECTION FOR COOLING

Step 1: Load Determination

Assume we have determined that the appropriate cooling load at the desired dry bulb 80°F and wet bulb 65°F conditions is as follows:

Total Cooling 22,000 Btuh
Sensible Cooling 18,200 Btuh
Entering Air Temp..... 80°F Dry Bulb / 65°F Wet Bulb

Step 2: Design Conditions

Similarly, we have also obtained the following design parameters:

Entering Water Temp 90°F
Water Flow (Based upon 10°F rise in temp) .4.5 GPM
Airflow 600 CFM

Steps 3, 4, and 5: HP Selection

After making our preliminary selection (ME024), we enter the tables at design water flow and water temperature and read Total Cooling, Sensible Cooling and Heat of Rejection capacities:

Total Cooling 22,500 Btuh
Sensible Cooling 16,500 Btuh
Heat of Rejection 28,800 Btuh

Steps 6 and 7: Entering Airflow Corrections

Next, we determine our correction factors.

Corrected Values	Table	Ent Air	Airflow	Corrected
Corrected Total Cooling	= 22,500 x	0.976	x 0.967	= 21,235
Corrected Sensible Cooling	= 16,500 x	0.919	x 1.089	= 16,513
Corrected Heat of Rejection	= 28,800 x	0.969	x 0.972	= 27,126

Step 8: Water Temperature Rise Calculation and Assessment

Actual Temperature Rise 12.1°F

When we compare the Corrected Total Cooling and Corrected Sensible Cooling figures with our load requirements stated in Step 1, we discover that our selection is within ±10% of our sensible load requirement. Furthermore, we see that our Corrected Total Cooling figure is within 1,000 Btuh the actual indicated load.

Heat Controller works continually to improve its products. As a result, the design and specifications of each product at the time of order may be changed without notice and may not be as described herein. Please contact Heat Controller's Customer Service Department at 517-787-2100 for specific information on the current design and specifications. Statements and other information contained herein are not express warranties and do not form the basis of any bargain between the parties, but are merely Heat Controller's opinion or commendation of its products. The latest version of this document is available at www.heatcontroller.com. Engineered and assembled in the USA. © Heat Controller, Inc. All Rights Reserved 2024

Model Nomenclature

1 | 2 | 3 | 4 | 5 | 6 | 7 | 8 | 9 | 10 | 11 | 12 | 13 | 14 | 15
M | **E** | **L** | **O** | **2** | **4** | **A** | **G** | **D** | **D** | **O** | **R** | **O** | **V** | **S**

MODEL

M = R-454B Refrigerant

MODEL TYPE

E = Premier Two-Stage Series

SUPPLY & RETURN CONFIGURATIONS

Horizontal Configuration		
	Left	Right
Straight	L	R
Back	B	P
Down Flow Configuration		
	Left	Right
Down	D	N
Vertical Configuration		
	Left	Right
Top	T	K

SIZE

024 060
 036 072
 048

REVISION

A = Current

VOLTAGE¹

G = 208/230-1-60
 J = 208/230-1-60 Refrigerant Detection System

CONTROLS

Control	Standard	Soft Start
DXM2.6	D	4
DXM2.6 with Disconnect	B	-

STANDARD

S = Standard

BLOWER MOTOR

V = Constant Volume (CV) EC

EXTENDED OPTIONS

O = Standard
 P = HWG and Pump

DRAIN PAN/HEAT EXCHANGER OPTIONS³

S = Stainless Steel Drain Pan, Non-Coated Microchannel Air Coil
 R = Stainless Steel Drain Pan, Tin-Coated Air Coil

WATER/HEAT EXCHANGER OPTIONS²

Water Option	Standard	Cupro-Nickel
None	0	Z
MOD Valve, Low System Pressure Drop	C	-
MOD Valve, High System Pressure Drop	-	P
Internal Flow Controller High Head with Check Valve	2	

CABINET

D = Residential

NOTES:

- SE sizes 060 and 072 require J voltage.
- All Open Loop Variable Water Flow Water Circuit Options require a cupronickel Heat Exchanger. All Closed Loop Variable Water Flow Water Circuit Options require a Standard Heat Exchanger. If no Water Circuit Option is selected, then the Heat Exchanger can be either Standard or Cupronickel.
- SE 024-048 offered with Microchannel Air coil only, SE 060-072 offered with Tin-Coated Air coil only.

Performance Data AHRI/ASHRAE/ISO 13256-1

Models:
ME
024-072

ASHRAE/AHRI/ISO 13256-1 English (I-P) Units

Model	Motor Type	Load	Water-Loop Heat Pump				Ground-Water Heat Pump				Ground-Loop Heat Pump			
			Cooling 86°F		Heating 68°F		Cooling 59°F		Heating 50°F		Cooling 68°F		Heating 41°F	
			Capacity Btuh	EER Btuh/W	Capacity Btuh	COP	Capacity Btuh	EER Btuh/W	Capacity Btuh	COP	Capacity Btuh	EER Btuh/W	Capacity Btuh	COP
ME024	EC	P	18,000	18.6	20,800	6.6	21,300	33.0	16,800	5.4	20,300	27.9	14,400	4.6
	EC	F	25,300	17.0	29,000	5.7	28,600	26.1	23,700	5.0	26,300	19.9	17,800	4.1
ME036	EC	P	28,000	19.5	31,000	6.1	31,500	32.0	25,900	5.1	30,000	26.0	22,600	4.6
	EC	F	38,000	17.5	43,100	5.5	42,000	25.0	36,000	4.9	39,200	19.5	28,400	4.2
ME048	EC	P	37,500	19.8	42,400	6.6	42,000	34.0	34,000	5.3	40,500	28.0	29,900	4.6
	EC	F	51,000	18.0	58,700	5.6	56,000	27.0	47,300	4.9	52,000	20.2	37,600	4.1
ME060	EC	P	44,000	18.6	45,300	5.9	49,000	30.8	36,000	4.4	47,000	25.1	31,000	4.1
	EC	F	61,800	16.9	67,300	5.3	66,800	24.7	55,700	4.7	62,600	18.7	44,300	3.9
ME072	EC	P	54,900	17.3	60,000	5.4	61,300	25.3	49,000	4.6	59,000	24.3	43,000	4.1
	EC	F	72,000	16.1	81,400	4.9	78,000	22.4	67,400	4.4	74,700	18.4	54,000	3.8

Notes:

- Where dual voltages are available ratings are based on the lower voltage setting.
- Cooling capacities based upon 80.6°F DB, 66.2°F WB entering air temperature.
- Heating capacities based upon 68°F DB, 59°F WB entering air temperature.
- Ground-Loop Heat Pump ratings based on 15% antifreeze solution.

ASHRAE/AHRI/ISO 13256-1 Metric (S-I) Units

Model	Motor Type	Load	Water-Loop Heat Pump				Ground-Water Heat Pump				Ground-Loop Heat Pump			
			Cooling 30°C		Heating 20°C		Cooling 15°C		Heating 10°C		Full Cooling 20°C		Full Heating 5°C	
			Capacity kW	EER W/W	Capacity kW	COP	Capacity kW	EER W/W	Capacity kW	COP	Capacity kW	EER W/W	Capacity kW	COP
ME024	EC	P	5.0	5.5	6.0	6.6	6.0	9.7	5.0	5.4	6.0	8.2	4.0	4.6
	EC	F	7.0	5.0	8.0	5.7	8.0	7.7	7.0	5.0	8.0	5.8	5.0	4.1
ME036	EC	P	8.0	5.7	9.0	6.1	9.0	9.4	8.0	5.1	9.0	7.6	7.0	4.6
	EC	F	11.0	5.1	13.0	5.5	12.0	7.3	11.0	4.9	11.0	5.7	8.0	4.2
ME048	EC	P	11.0	5.8	12.0	6.6	12.0	10.0	10.0	5.3	12.0	8.2	9.0	4.6
	EC	F	15.0	5.3	17.0	5.6	16.0	7.9	14.0	4.9	15.0	5.9	11.0	4.1
ME060	EC	P	13.0	5.5	13.0	5.9	14.0	9.0	11.0	4.4	14.0	7.4	9.0	4.1
	EC	F	18.0	5.0	20.0	5.3	20.0	7.2	16.0	4.7	18.0	5.5	13.0	3.9
ME072	EC	P	16.0	5.1	18.0	5.4	18.0	7.4	14.0	4.6	17.0	7.1	13.0	4.1
	EC	F	21.0	4.7	24.0	4.9	23.0	6.6	20.0	4.4	22.0	5.4	16.0	3.8

Notes:

- Where dual voltages are available ratings are based on the lower voltage setting.
- Cooling capacities based upon 20°C DB, 15°C WB entering air temperature.
- Heating capacities based upon 20°C DB, 15°C WB entering air temperature.
- Ground-Loop Heat Pump ratings based on 15% antifreeze solution.

Performance Data Selection Notes

Models:
ME
024-072

For operation in the shaded area when water is used instead of an antifreeze solution, the LWT (Leaving Water Temperature) must be calculated. Flow must be maintained to a level such that the LWT is maintained above 40°F (4.4°C) when the JW3 jumper is not clipped (see example below). Otherwise, use appropriate levels of a proper antifreeze solution in systems with leaving water temperatures of 40°F (4.4°C) or below and clip the JW3 jumper. This is due to the potential of the refrigerant temperature being as low as 32°F (0°C) with 40°F (4.4°C) LWT, which may lead to a nuisance cutout due to the activation of the Low Temperature Protection. Never clip JW3 for standard-range equipment or systems without antifreeze.

Example:

At 50°F EWT (Entering Water Temperature) and 1.5 GPM/ton, a 3-ton unit has a HE of 22,500 Btuh. To calculate LWT, rearrange the formula for HE as follows:

$HE = TD \times GPM \times 500$, where HE = Heat of Extraction (Btuh); TD = temperature difference (EWT - LWT) and GPM = U.S. Gallons per Minute.

$$TD = HE / (GPM \times 500)$$

$$TD = 22,500 / (1.5 \times 500)$$

$$TD = 10^\circ F$$

$$LWT = EWT - TD$$

$$LWT = 50 - 10 = 40^\circ F$$

In this example, as long as the EWT does not fall below 50°F, the system will operate as designed. For EWTs below 50°F, higher flow rates will be required (open loop systems, for example, require at least 2 GPM/ton when EWT is below 50°F).

Heating - EAT 70°F						
	EER	HC	Power kW	HE	LAT	COP
Not Recommended						
		4.0	0.45	2.5	84.6	2.6
8.6	27.4	4.6	0.46	3.0	86.8	2.9
8.6	31.0	4.8	0.47	3.2	87.8	3.0
8.6	33.0	4.9	0.47	3.3	88.3	3.1
8.4	23.3	5.4	0.48	3.8	90.2	3.3
8.5	26.3	5.7	0.49	4.0	91.4	3.4
8.6	27.9	5.9	0.49	4.2	92.1	3.5
8.2	19.8	6.2	0.50	4.5	93.6	3.7
4	22.3	6.6	0.50	4.9	95.0	3.8
	23.7	6.8	0.51	5.0	95.8	3.9
	16.7	7.0	0.51	5.3	96.9	4.0
	8.8	7.4	0.52	5.6	98.5	4.1
		7.6	0.52	5.8	99.3	4.2
			0.53	6.0	100.0	4.3

Heat Controller works continually to improve its products. As a result, the design and specifications of each product at the time of order may be changed without notice and may not be as described herein. Please contact Heat Controller's Customer Service Department at 517-787-2100 for specific information on the current design and specifications. Statements and other information contained herein are not express warranties and do not form the basis of any bargain between the parties, but are merely Heat Controller's opinion or commendation of its products. The latest version of this document is available at www.heatcontroller.com. Engineered and assembled in the USA. © Heat Controller, Inc. All Rights Reserved 2024

Performance Data ME024 EC Blower Motor (Part Load)

Models:
ME
024-072

700 CFM Rated Airflow

EWT °F	WPD			Cooling - EAT 80/67°F							WPD			Heating - EAT 70°F						
	FLOW GPM	PSI	FT	TC	SC	kW	HR	EER	LWT	HWG Cap	FLOW GPM	PSI	FT	HC	kW	HE	COP	LWT	HWG Cap	
20	3.5	Operation Not Recommended										4.7	0.7	1.5	10.7	1.1	7.0	2.9	17.0	1.2
	4.7																			
30	2.4	0.1	0.3	20.8	13.8	0.5	22.6	38.4	49.3	0.2	2.4	0.1	0.3	12.3	1.1	8.5	3.3	22.7	1.3	
	3.5	0.2	0.5	20.1	12.9	0.5	21.8	40.0	42.4	0.2	3.5	0.2	0.5	12.8	1.1	9.1	3.4	24.8	1.4	
	4.7	0.5	1.2	19.6	12.4	0.5	21.3	40.2	39.1	0.2	4.7	0.5	1.2	13.1	1.1	9.4	3.5	26.0	1.4	
40	2.4	0.1	0.3	21.3	14.7	0.6	23.4	34.0	59.9	0.4	2.4	0.1	0.3	14.4	1.1	10.7	3.9	30.9	1.4	
	3.5	0.2	0.4	21.0	14.2	0.6	23.0	37.0	53.0	0.4	3.5	0.2	0.4	15.1	1.1	11.4	4.1	33.5	1.4	
	4.7	0.4	1.0	20.8	13.9	0.5	22.7	38.3	49.6	0.4	4.7	0.4	1.0	15.5	1.1	11.8	4.2	35.0	1.5	
50	2.4	0.1	0.3	21.2	15.1	0.7	23.7	29.0	70.2	0.7	2.4	0.1	0.3	16.5	1.1	12.8	4.5	39.1	1.5	
	3.5	0.2	0.3	21.3	14.9	0.7	23.6	32.4	63.4	0.7	3.5	0.2	0.3	17.3	1.1	13.6	4.7	42.3	1.6	
	4.7	0.4	0.9	21.3	14.7	0.6	23.4	34.0	60.0	0.7	4.7	0.4	0.9	17.8	1.1	14.1	4.8	44.0	1.6	
60	2.4	0.1	0.3	20.7	15.1	0.9	23.6	24.1	80.1	1.1	2.4	0.1	0.3	18.6	1.1	14.9	5.0	47.3	1.7	
	3.5	0.1	0.3	21.1	15.1	0.8	23.7	27.3	73.5	1.1	3.5	0.1	0.3	19.5	1.1	15.8	5.3	51.0	1.7	
	4.7	0.3	0.8	21.2	15.1	0.7	23.7	29.0	70.1	1.0	4.7	0.3	0.8	20.0	1.1	16.3	5.4	53.1	1.8	
70	2.4	0.1	0.3	19.8	14.8	1.0	23.2	19.8	89.7	1.6	2.4	0.1	0.3	20.6	1.1	16.9	5.6	55.6	1.8	
	3.5	0.1	0.3	20.4	15.0	0.9	23.5	22.6	83.3	1.5	3.5	0.1	0.3	21.6	1.1	17.9	5.8	59.8	1.9	
	4.7	0.3	0.7	20.7	15.1	0.9	23.6	24.1	80.0	1.5	4.7	0.3	0.7	22.2	1.1	18.5	6.0	62.1	1.9	
80	2.4	0.1	0.3	18.6	14.4	1.2	22.6	16.1	99.2	2.2	2.4	0.1	0.3	22.6	1.1	18.9	6.1	63.9	2.0	
	3.5	0.1	0.3	19.4	14.7	1.1	23.0	18.4	93.0	2.1	3.5	0.1	0.3	23.7	1.1	20.0	6.4	68.7	2.1	
	4.7	0.3	0.7	19.8	14.8	1.0	23.2	19.7	89.9	2.0	4.7	0.3	0.7	24.3	1.1	20.5	6.5	71.3	2.1	
85	2.4	0.1	0.3	18.0	14.1	1.2	22.2	14.5	103.9	2.4	2.4	0.1	0.3	23.6	1.1	19.8	6.3	68.1	2.1	
	3.5	0.1	0.3	18.8	14.4	1.1	22.7	16.6	97.9	2.4	3.5	0.1	0.3	24.7	1.1	21.0	6.6	73.1	2.1	
	4.7	0.3	0.6	19.2	14.6	1.1	22.9	17.8	94.7	2.3	4.7	0.3	0.6	25.3	1.1	21.6	6.8	75.8	2.2	
90	2.4	0.1	0.3	17.2	13.8	1.3	21.8	13.0	108.5	2.9	2.4	0.1	0.3	24.5	1.1	20.8	6.6	72.3	2.2	
	3.5	0.1	0.3	18.1	14.2	1.2	22.3	14.9	102.6	2.8	3.5	0.1	0.3	25.7	1.1	21.9	6.9	77.6	2.3	
	4.7	0.3	0.6	18.6	14.3	1.2	22.5	16.0	99.6	2.7	4.7	0.3	0.6	26.3	1.1	22.5	7.0	80.4	2.3	
100	2.4	0.1	0.3	15.7	13.2	1.5	20.9	10.4	117.8	3.7	Operation Not Recommended									
	3.5	0.1	0.3	16.7	13.6	1.4	21.4	12.0	112.2	3.6										
	4.7	0.2	0.5	17.1	13.8	1.3	21.7	12.8	109.2	3.5										
110	2.4	0.1	0.3	14.2	12.6	1.7	20.0	8.3	127.0	4.6										
	3.5	0.1	0.3	15.1	12.9	1.6	20.5	9.5	121.6	4.4										
	4.7	0.2	0.4	15.6	13.1	1.5	20.8	10.2	118.8	4.3										
120	2.4	0.1	0.3	12.6	11.9	1.9	19.1	6.6	136.2	5.6										
	3.5	0.1	0.3	13.4	12.3	1.8	19.6	7.5	131.1	5.4										
	4.7	0.1	0.3	13.9	12.5	1.7	19.8	8.0	128.4	5.3										

- Interpolation is permissible; extrapolation is not.
- All entering air conditions are 80°F (26.6°C) DB and 67°F (19.4°C) WB in cooling, and 70°F (21°C) DB in heating.
- AHRI/ISO certified conditions are 80.6°F (27°C) DB and 66.2°F (19°C) WB in cooling and 68°F (20°C) DB in heating.
- Table does not reflect fan or pump power corrections for AHRI/ISO conditions.
- All performance is based upon the lower voltage of dual voltage rated units.
- Performance stated is at the rated power supply; performance may vary as the power supply varies from the rated.
- Operation below 40°F (10.0°C) EWT is based upon 20% methanol antifreeze solution.
- Operation below 60°F (15.5°C) EWT requires optional insulated water/refrigerant circuit.
- See performance correction tables for operating conditions other than those listed above.
- See Performance Data Selection Notes for operation in the shaded areas.
- Regular Cooling operation with an EWT of less than 50°F (10.0°C) is not recommended unless variable water flow is available.
- Regular Heating operation with an EWT of more than 90°F (32°C) is not recommended unless variable water flow is available.
- For quiet operation and long term reliability, it is recommended that systems be designed to avoid continuous operation in the outlined areas.
- Performance capacities shown in thousands of Btuh
- Hot Water Generator Capacity is based on 90°F entering water and 0.5 GPM/Ton.

Heat Controller works continually to improve its products. As a result, the design and specifications of each product at the time of order may be changed without notice and may not be as described herein. Please contact Heat Controller's Customer Service Department at 517-787-2100 for specific information on the current design and specifications. Statements and other information contained herein are not express warranties and do not form the basis of any bargain between the parties, but are merely Heat Controller's opinion or commendation of its products. The latest version of this document is available at www.heatcontroller.com. Engineered and assembled in the USA. © Heat Controller, Inc. All Rights Reserved 2024

Performance Data ME024 EC Blower Motor (Full Load)

Models:
ME
024-072

800 CFM Rated Airflow

EWT °F	WPD			COOLING - EAT 80/67 °F							WPD			HEATING - EAT 70°F						
	FLOW GPM	PSI	FT	TC	SC	kW	HR	EER	LWT	HWG Cap	FLOW GPM	PSI	FT	HC	kW	HE	COP	LWT	HWG Cap	
20	4.5	Operation Not Recommended										6.0	1.2	2.7	16.2	1.5	11.1	3.2	16.3	1.9
	6.0																			
30	3.0	0.1	0.3	27.3	17.7	1.0	30.5	28.3	50.4	1.6	3.0	0.1	0.3	17.9	1.5	12.8	3.5	21.5	2.0	
	4.5	0.5	1.2	26.4	16.7	0.9	29.4	29.6	43.1	1.4	4.5	0.5	1.2	18.7	1.5	13.6	3.7	24.0	2.2	
	6.0	1.0	2.3	25.8	16.1	0.9	28.8	30.0	39.6	1.3	6.0	1.0	2.3	19.2	1.5	14.0	3.7	25.3	2.5	
40	3.0	0.1	0.3	27.9	18.6	1.1	31.6	25.8	61.0	1.5	3.0	0.1	0.3	20.6	1.5	15.4	4.0	29.7	2.2	
	4.5	0.4	1.0	27.5	18.0	1.0	30.9	27.5	53.8	1.4	4.5	0.4	1.0	21.6	1.5	16.3	4.1	32.7	2.5	
	6.0	0.9	2.1	27.2	17.7	1.0	30.5	28.3	50.2	1.3	6.0	0.9	2.1	22.1	1.5	16.8	4.2	34.4	2.7	
50	3.0	0.1	0.3	27.8	18.9	1.2	32.0	23.0	71.3	1.7	3.0	0.1	0.3	23.2	1.5	18.0	4.4	38.0	2.5	
	4.5	0.4	0.8	27.9	18.7	1.1	31.7	25.0	64.1	1.5	4.5	0.4	0.8	24.3	1.6	19.0	4.6	41.6	2.7	
	6.0	0.8	1.9	27.9	18.6	1.1	31.5	25.9	60.5	1.4	6.0	0.8	1.9	24.9	1.6	19.6	4.6	43.5	3.0	
60	3.0	0.1	0.3	27.3	18.8	1.4	31.9	20.2	81.3	2.1	3.0	0.1	0.3	25.8	1.6	20.4	4.8	46.4	2.8	
	4.5	0.3	0.7	27.7	18.9	1.2	32.0	22.2	74.2	1.9	4.5	0.3	0.7	27.1	1.6	21.6	4.9	50.4	3.1	
	6.0	0.8	1.7	27.9	18.9	1.2	31.9	23.2	70.6	1.8	6.0	0.8	1.7	27.8	1.6	22.2	5.0	52.6	3.3	
70	3.0	0.1	0.3	26.3	18.4	1.5	31.5	17.4	91.0	2.7	3.0	0.1	0.3	28.4	1.6	22.9	5.1	54.8	3.1	
	4.5	0.3	0.6	27.0	18.7	1.4	31.8	19.4	84.1	2.4	4.5	0.3	0.6	29.8	1.7	24.2	5.3	59.3	3.5	
	6.0	0.7	1.6	27.3	18.8	1.3	31.9	20.4	80.6	2.2	6.0	0.7	1.6	30.6	1.7	24.9	5.4	61.7	3.8	
80	3.0	0.1	0.3	25.1	17.9	1.7	30.9	14.8	100.6	3.4	3.0	0.1	0.3	31.0	1.7	25.3	5.4	63.2	3.5	
	4.5	0.2	0.5	26.0	18.3	1.6	31.4	16.6	93.9	3.1	4.5	0.2	0.5	32.5	1.7	26.7	5.6	68.1	3.9	
	6.0	0.7	1.6	26.4	18.5	1.5	31.5	17.5	90.5	2.8	6.0	0.7	1.6	33.4	1.7	27.5	5.7	70.8	4.3	
85	3.0	0.1	0.3	24.4	17.6	1.8	30.6	13.6	105.4	3.5	3.0	0.1	0.3	32.3	1.7	26.5	5.6	67.4	3.7	
	4.5	0.2	0.5	25.4	18.0	1.7	31.0	15.3	98.8	3.3	4.5	0.2	0.5	33.9	1.7	28.0	5.7	72.6	4.1	
	6.0	0.7	1.5	25.8	18.2	1.6	31.3	16.2	95.4	3.2	6.0	0.7	1.5	34.8	1.8	28.8	5.8	75.4	4.4	
90	3.0	0.1	0.3	23.7	17.2	1.9	30.2	12.4	110.1	4.4	3.0	0.1	0.3	33.6	1.7	27.7	5.7	71.5	4.0	
	4.5	0.2	0.5	24.7	17.7	1.8	30.7	14.0	103.6	4.0	4.5	0.2	0.5	35.3	1.8	29.3	5.9	77.0	4.4	
	6.0	0.6	1.5	25.2	17.9	1.7	30.9	14.9	100.3	3.6	6.0	0.6	1.5	36.2	1.8	30.1	5.9	80.0	4.8	
100	3.0	0.1	0.3	22.1	16.6	2.2	29.5	10.3	119.6	5.4	Operation Not Recommended									
	4.5	0.2	0.4	23.2	17.0	2.0	30.0	11.7	113.3	5.0										
	6.0	0.6	1.4	23.7	17.2	1.9	30.2	12.4	110.1	4.1										
110	3.0	0.1	0.3	20.5	15.9	2.4	28.8	8.4	129.2	6.7										
	4.5	0.2	0.4	21.6	16.3	2.2	29.2	9.6	123.0	6.2										
	6.0	0.6	1.3	22.1	16.6	2.2	29.5	10.2	119.8	5.1										
120	3.0	0.1	0.3	18.9	15.4	2.8	28.3	6.9	138.8	8.2										
	4.5	0.1	0.3	19.9	15.7	2.5	28.6	7.8	132.7	7.5										
	6.0	0.5	1.1	20.4	15.9	2.4	28.8	8.4	129.6	6.2										

- Interpolation is permissible; extrapolation is not.
- All entering air conditions are 80°F (26.6°C) DB and 67°F (19.4°C) WB in cooling, and 70°F (21°C) DB in heating.
- AHRI/ISO certified conditions are 80.6°F (27°C) DB and 66.2°F (19°C) WB in cooling and 68°F (20°C) DB in heating.
- Table does not reflect fan or pump power corrections for AHRI/ISO conditions.
- All performance is based upon the lower voltage of dual voltage rated units.
- Performance stated is at the rated power supply; performance may vary as the power supply varies from the rated.
- Operation below 40°F (10.0°C) EWT is based upon 20% methanol antifreeze solution.
- Operation below 60°F (15.5°C) EWT requires optional insulated water/refrigerant circuit.
- See performance correction tables for operating conditions other than those listed above.
- See Performance Data Selection Notes for operation in the shaded areas.
- Regular Cooling operation with an EWT of less than 50°F (10.0°C) is not recommended unless variable water flow is available.
- Regular Heating operation with an EWT of more than 90°F (32°C) is not recommended unless variable water flow is available.
- For quiet operation and long term reliability, it is recommended that systems be designed to avoid continuous operation in the outlined areas.
- Performance capacities shown in thousands of Btuh
- Hot Water Generator Capacity is based on 90°F entering water and 0.5 GPM/Ton.

Heat Controller works continually to improve its products. As a result, the design and specifications of each product at the time of order may be changed without notice and may not be as described herein. Please contact Heat Controller's Customer Service Department at 517-787-2100 for specific information on the current design and specifications. Statements and other information contained herein are not express warranties and do not form the basis of any bargain between the parties, but are merely Heat Controller's opinion or commendation of its products. The latest version of this document is available at www.heatcontroller.com. Engineered and assembled in the USA. © Heat Controller, Inc. All Rights Reserved 2024

ME024 EC Blower Motor Modulating Flow (Part Load)

Models:
ME
024-072

700 CFM Rated Airflow

EWT °F	WPD			COOLING - EAT 80/67 °F							WPD			HEATING - EAT 70°F					
	FLOW GPM	PSI	FT	TC	SC	kW	HR	EER	LWT	HWG Cap	FLOW GPM	PSI	FT	HC	kW	HE	COP	LWT	HWG Cap
20	3.5	Operation Not Recommended																	
	4.7										4.7	0.7	1.5	10.7	1.1	7.0	2.9	17.0	1.2
30	1.6	0.1	0.2	22.0	15.3	0.6	24.0	36.8	60.0	0.2	2.4	0.1	0.3	12.3	1.1	8.5	3.3	22.7	1.3
	1.6	0.1	0.2	22.0	15.3	0.6	24.0	36.8	60.0	0.2	3.5	0.2	0.5	12.8	1.1	9.1	3.4	24.8	1.4
	1.6	0.1	0.2	22.0	15.3	0.6	24.0	36.8	60.0	0.2	4.7	0.5	1.2	13.1	1.1	9.4	3.5	26.0	1.4
40	2.3	0.1	0.2	21.3	14.7	0.6	23.4	34.1	60.0	0.2	2.4	0.1	0.3	14.4	1.1	10.7	3.9	30.9	1.4
	2.3	0.1	0.2	21.3	14.7	0.6	23.4	34.1	60.0	0.2	3.5	0.2	0.4	15.1	1.1	11.4	4.1	33.5	1.4
	2.3	0.1	0.2	21.3	14.7	0.6	23.4	34.1	60.0	0.2	4.7	0.4	1.0	15.5	1.1	11.8	4.2	35.0	1.5
50	2.4	0.1	0.3	21.2	15.1	0.7	23.7	29.0	70.2	0.7	2.4	0.1	0.3	16.5	1.1	12.8	4.5	39.1	1.5
	3.5	0.2	0.3	21.3	14.9	0.7	23.6	32.4	63.4	0.7	3.5	0.2	0.3	17.3	1.1	13.6	4.7	42.3	1.6
	4.7	0.4	0.9	21.3	14.7	0.6	23.4	34.0	60.0	0.7	4.7	0.4	0.9	17.8	1.1	14.1	4.8	44.0	1.6
60	2.4	0.1	0.3	20.7	15.1	0.9	23.6	24.1	80.1	1.1	2.4	0.1	0.3	18.6	1.1	14.9	5.0	47.3	1.7
	3.5	0.1	0.3	21.1	15.1	0.8	23.7	27.3	73.5	1.1	3.5	0.1	0.3	19.5	1.1	15.8	5.3	51.0	1.7
	4.7	0.3	0.8	21.2	15.1	0.7	23.7	29.0	70.1	1.0	4.7	0.3	0.8	20.0	1.1	16.3	5.4	53.1	1.8
70	2.4	0.1	0.3	19.8	14.8	1.0	23.2	19.8	89.7	1.6	2.4	0.1	0.3	20.6	1.1	16.9	5.6	55.6	1.8
	3.5	0.1	0.3	20.4	15.0	0.9	23.5	22.6	83.3	1.5	3.5	0.1	0.3	21.6	1.1	17.9	5.8	59.8	1.9
	4.7	0.3	0.7	20.7	15.1	0.9	23.6	24.1	80.0	1.5	4.7	0.3	0.7	22.2	1.1	18.5	6.0	62.1	1.9
80	2.4	0.1	0.3	18.6	14.4	1.2	22.6	16.1	99.2	2.2	2.4	0.1	0.3	22.6	1.1	18.9	6.1	63.9	2.0
	3.5	0.1	0.3	19.4	14.7	1.1	23.0	18.4	93.0	2.1	3.5	0.1	0.3	23.7	1.1	20.0	6.4	68.7	2.1
	4.7	0.3	0.7	19.8	14.8	1.0	23.2	19.7	89.9	2.0	4.7	0.3	0.7	24.3	1.1	20.5	6.5	71.3	2.1
85	2.4	0.1	0.3	18.0	14.1	1.2	22.2	14.5	103.9	2.4	2.4	0.1	0.3	23.6	1.1	19.8	6.3	68.1	2.1
	3.5	0.1	0.3	18.8	14.4	1.1	22.7	16.6	97.9	2.4	3.5	0.1	0.3	24.7	1.1	21.0	6.6	73.1	2.1
	4.7	0.3	0.6	19.2	14.6	1.1	22.9	17.8	94.7	2.3	4.7	0.3	0.6	25.3	1.1	21.6	6.8	75.8	2.2
90	2.4	0.1	0.3	17.2	13.8	1.3	21.8	13.0	108.5	2.9	2.4	0.1	0.3	24.5	1.1	20.8	6.6	72.3	2.2
	3.5	0.1	0.3	18.1	14.2	1.2	22.3	14.9	102.6	2.8	3.5	0.1	0.3	25.7	1.1	21.9	6.9	77.6	2.3
	4.7	0.3	0.6	18.6	14.3	1.2	22.5	16.0	99.6	2.7	4.7	0.3	0.6	26.3	1.1	22.5	7.0	80.4	2.3
100	2.4	0.1	0.3	15.7	13.2	1.5	20.9	10.4	117.8	3.7	1.4	0.1	0.2	24.0	1.1	20.3	6.5	70.0	2.2
	3.5	0.1	0.3	16.7	13.6	1.4	21.4	12.0	112.2	3.6	1.4	0.1	0.2	24.0	1.1	20.3	6.5	70.0	2.2
	4.7	0.2	0.5	17.1	13.8	1.3	21.7	12.8	109.2	3.5	1.4	0.1	0.2	24.0	1.1	20.3	6.5	70.0	2.2
110	2.4	0.1	0.3	14.2	12.6	1.7	20.0	8.3	127.0	4.6	1.0	0.1	0.2	24.0	1.1	20.3	6.5	70.0	2.2
	3.5	0.1	0.3	15.1	12.9	1.6	20.5	9.5	121.6	4.4	1.0	0.1	0.2	24.0	1.1	20.3	6.5	70.0	2.2
	4.7	0.2	0.4	15.6	13.1	1.5	20.8	10.2	118.8	4.3	1.0	0.1	0.2	24.0	1.1	20.3	6.5	70.0	2.2
120	2.4	0.1	0.3	12.6	11.9	1.9	19.1	6.6	136.2	5.6	0.8	0.1	0.2	24.0	1.1	20.3	6.5	70.0	2.2
	3.5	0.1	0.3	13.4	12.3	1.8	19.6	7.5	131.1	5.4	0.8	0.1	0.2	24.0	1.1	20.3	6.5	70.0	2.2
	4.7	0.1	0.3	13.9	12.5	1.7	19.8	8.0	128.4	5.3	0.8	0.1	0.2	24.0	1.1	20.3	6.5	70.0	2.2

- Interpolation is permissible; extrapolation is not.
- All entering air conditions are 80°F (26.6°C) DB and 67°F (19.4°C) WB in cooling, and 70°F (21°C) DB in heating.
- AHRI/ISO certified conditions are 80.6°F (27°C) DB and 66.2°F (19°C) WB in cooling and 68°F (20°C) DB in heating.
- Table does not reflect fan or pump power corrections for AHRI/ISO conditions.
- All performance is based upon the lower voltage of dual voltage rated units.
- Performance stated is at the rated power supply; performance may vary as the power supply varies from the rated.
- Operation below 40°F (10.0°C) EWT is based upon 20% methanol antifreeze solution.
- Operation below 60°F (15.5°C) EWT requires optional insulated water/refrigerant circuit.
- See performance correction tables for operating conditions other than those listed above.
- See Performance Data Selection Notes for operation in the shaded areas.
- Regular Cooling operation with an EWT of less than 50°F (10.0°C) is not recommended unless variable water flow is available.
- Regular Heating operation with an EWT of more than 90°F (32°C) is not recommended unless variable water flow is available.
- For quiet operation and long term reliability, it is recommended that systems be designed to avoid continuous operation in the outlined areas.
- Performance capacities shown in thousands of Btuh
- Hot Water Generator Capacity is based on 90°F entering water and 0.5 GPM/Ton.

Heat Controller works continually to improve its products. As a result, the design and specifications of each product at the time of order may be changed without notice and may not be as described herein. Please contact Heat Controller's Customer Service Department at 517-787-2100 for specific information on the current design and specifications. Statements and other information contained herein are not express warranties and do not form the basis of any bargain between the parties, but are merely Heat Controller's opinion or commendation of its products. The latest version of this document is available at www.heatcontroller.com. Engineered and assembled in the USA. © Heat Controller, Inc. All Rights Reserved 2024

ME024 EC Blower Motor Modulating Flow (Full Load)

Models:
ME
024-072

800 CFM Rated Airflow

EWT °F	WPD			COOLING - EAT 80/67 °F							WPD			HEATING - EAT 70°F						
	FLOW GPM	PSI	FT	TC	SC	kW	HR	EER	LWT	HWG Cap	FLOW GPM	PSI	FT	HC	kW	HE	COP	LWT	HWG Cap	
20	4.5	Operation Not Recommended																		
	6.0											6.0	1.2	2.7	16.2	1.5	11.1	3.2	16.3	1.9
30	2.1	0.1	0.2	28.5	19.1	1.1	32.1	27.0	60.0	1.4	3.0	0.1	0.3	17.9	1.5	12.8	3.5	21.5	2.0	
	2.1	0.1	0.2	28.5	19.1	1.1	32.1	27.0	60.0	1.4	4.5	0.5	1.2	18.7	1.5	13.6	3.7	24.0	2.2	
	2.1	0.1	0.2	28.5	19.1	1.1	32.1	27.0	60.0	1.4	6.0	1.0	2.3	19.2	1.5	14.0	3.7	25.3	2.5	
40	3.1	0.1	0.3	27.8	18.5	1.1	31.5	26.0	60.0	1.4	3.0	0.1	0.3	20.6	1.5	15.4	4.0	29.7	2.2	
	3.1	0.1	0.3	27.8	18.5	1.1	31.5	26.0	60.0	1.4	4.5	0.4	1.0	21.6	1.5	16.3	4.1	32.7	2.5	
	3.1	0.1	0.3	27.8	18.5	1.1	31.5	26.0	60.0	1.4	6.0	0.9	2.1	22.1	1.5	16.8	4.2	34.4	2.7	
50	3.0	0.1	0.3	27.8	18.9	1.2	32.0	23.0	71.3	1.7	3.0	0.1	0.3	23.2	1.5	18.0	4.4	38.0	2.5	
	4.5	0.4	0.8	27.9	18.7	1.1	31.7	25.0	64.1	1.6	4.5	0.4	0.8	24.3	1.6	19.0	4.6	41.6	2.7	
	6.0	0.8	1.9	27.9	18.6	1.1	31.5	25.9	60.5	1.4	6.0	0.8	1.9	24.9	1.6	19.6	4.6	43.5	3.0	
60	3.0	0.1	0.3	27.3	18.8	1.4	31.9	20.2	81.3	2.1	3.0	0.1	0.3	25.8	1.6	20.4	4.8	46.4	2.8	
	4.5	0.3	0.7	27.7	18.9	1.2	32.0	22.2	74.2	1.9	4.5	0.3	0.7	27.1	1.6	21.6	4.9	50.4	3.1	
	6.0	0.8	1.7	27.9	18.9	1.2	31.9	23.2	70.6	1.8	6.0	0.8	1.7	27.8	1.6	22.2	5.0	52.6	3.3	
70	3.0	0.1	0.3	26.3	18.4	1.5	31.5	17.4	91.0	2.7	3.0	0.1	0.3	28.4	1.6	22.9	5.1	54.8	3.1	
	4.5	0.3	0.6	27.0	18.7	1.4	31.8	19.4	84.1	2.4	4.5	0.3	0.6	29.8	1.7	24.2	5.3	59.3	3.5	
	6.0	0.7	1.6	27.3	18.8	1.3	31.9	20.4	80.6	2.2	6.0	0.7	1.6	30.6	1.7	24.9	5.4	61.7	3.8	
80	3.0	0.1	0.3	25.1	17.9	1.7	30.9	14.8	100.6	3.4	3.0	0.1	0.3	31.0	1.7	25.3	5.4	63.2	3.5	
	4.5	0.2	0.5	26.0	18.3	1.6	31.4	16.6	93.9	3.1	4.5	0.2	0.5	32.5	1.7	26.7	5.6	68.1	3.9	
	6.0	0.7	1.6	26.4	18.5	1.5	31.5	17.5	90.5	2.8	6.0	0.7	1.6	33.4	1.7	27.5	5.7	70.8	4.3	
85	3.0	0.1	0.3	24.4	17.6	1.8	30.6	13.6	105.4	3.5	3.0	0.1	0.3	32.3	1.7	26.5	5.6	67.4	3.7	
	4.5	0.2	0.5	25.4	18.0	1.7	31.0	15.3	98.8	3.3	4.5	0.2	0.5	33.9	1.7	28.0	5.7	72.6	4.1	
	6.0	0.7	1.5	25.8	18.2	1.6	31.3	16.2	95.4	3.2	6.0	0.7	1.5	34.8	1.8	28.8	5.8	75.4	4.4	
90	3.0	0.1	0.3	23.7	17.2	1.9	30.2	12.4	110.1	4.4	2.7	0.1	0.2	33.1	1.7	27.2	5.6	70.0	4.4	
	4.5	0.2	0.5	24.7	17.7	1.8	30.7	14.0	103.6	4.0	2.7	0.1	0.2	33.1	1.7	27.2	5.6	70.0	4.4	
	6.0	0.6	1.5	25.2	17.9	1.7	30.9	14.9	100.3	3.6	2.7	0.1	0.2	33.1	1.7	27.2	5.6	70.0	4.4	
100	3.0	0.1	0.3	22.1	16.6	2.2	29.5	10.3	119.6	5.4	1.8	0.1	0.2	33.1	1.7	27.2	5.6	70.0	4.4	
	4.5	0.2	0.4	23.2	17.0	2.0	30.0	11.7	113.3	5.0	1.8	0.1	0.2	33.1	1.7	27.2	5.6	70.0	4.4	
	6.0	0.6	1.4	23.7	17.2	1.9	30.2	12.4	110.1	4.1	1.8	0.1	0.2	33.1	1.7	27.2	5.6	70.0	4.4	
110	3.0	0.1	0.3	20.5	15.9	2.4	28.8	8.4	129.2	6.7	1.4	0.1	0.2	33.1	1.7	27.2	5.6	70.0	4.4	
	4.5	0.2	0.4	21.6	16.3	2.2	29.2	9.6	123.0	6.2	1.4	0.1	0.2	33.1	1.7	27.2	5.6	70.0	4.4	
	6.0	0.6	1.3	22.1	16.6	2.2	29.5	10.2	119.8	5.1	1.4	0.1	0.2	33.1	1.7	27.2	5.6	70.0	4.4	
120	3.0	0.1	0.3	18.9	15.4	2.8	28.3	6.9	138.8	8.2	1.1	0.1	0.2	33.1	1.7	27.2	5.6	70.0	4.4	
	4.5	0.1	0.3	19.9	15.7	2.5	28.6	7.8	132.7	7.5	1.1	0.1	0.2	33.1	1.7	27.2	5.6	70.0	4.4	
	6.0	0.5	1.1	20.4	15.9	2.4	28.8	8.4	129.6	6.2	1.1	0.1	0.2	33.1	1.7	27.2	5.6	70.0	4.4	

- Interpolation is permissible; extrapolation is not.
- All entering air conditions are 80°F (26.6°C) DB and 67°F (19.4°C) WB in cooling, and 70°F (21°C) DB in heating.
- AHRI/ISO certified conditions are 80.6°F (27°C) DB and 66.2°F (19°C) WB in cooling and 68°F (20°C) DB in heating.
- Table does not reflect fan or pump power corrections for AHRI/ISO conditions.
- All performance is based upon the lower voltage of dual voltage rated units.
- Performance stated is at the rated power supply; performance may vary as the power supply varies from the rated.
- Operation below 40°F (10.0°C) EWT is based upon 20% methanol antifreeze solution.
- Operation below 60°F (15.5°C) EWT requires optional insulated water/refrigerant circuit.
- See performance correction tables for operating conditions other than those listed above.
- See Performance Data Selection Notes for operation in the shaded areas.
- Regular Cooling operation with an EWT of less than 50°F (10.0°C) is not recommended unless variable water flow is available.
- Regular Heating operation with an EWT of more than 90°F (32°C) is not recommended unless variable water flow is available.
- For quiet operation and long term reliability, it is recommended that systems be designed to avoid continuous operation in the outlined areas.
- Performance capacities shown in thousands of Btuh
- Hot Water Generator Capacity is based on 90°F entering water and 0.5 GPM/Ton.

Heat Controller works continually to improve its products. As a result, the design and specifications of each product at the time of order may be changed without notice and may not be as described herein. Please contact Heat Controller's Customer Service Department at 517-787-2100 for specific information on the current design and specifications. Statements and other information contained herein are not express warranties and do not form the basis of any bargain between the parties, but are merely Heat Controller's opinion or commendation of its products. The latest version of this document is available at www.heatcontroller.com. Engineered and assembled in the USA. © Heat Controller, Inc. All Rights Reserved 2024

Performance Data ME036 EC Blower Motor (Part Load)

Models:
ME
024-072

1,100 CFM Rated Airflow

EWT °F	WPD			Cooling - EAT 80/67°F							WPD			Heating - EAT 70°F						
	FLOW GPM	PSI	FT	TC	SC	kW	HR	EER	LWT	HWG Cap	FLOW GPM	PSI	FT	HC	kW	HE	COP	LWT	HWG Cap	
20	5.0	Operation Not Recommended										6.7	2.2	5.0	16.7	1.5	11.7	3.3	16.5	1.6
	6.7																			
30	3.4	0.6	1.4	30.5	19.5	0.8	33.2	37.7	49.8	1.1	3.4	0.6	1.4	18.9	1.5	13.8	3.7	21.7	1.7	
	5.0	1.2	2.7	28.5	17.8	0.8	31.1	37.7	42.4	1.1	5.0	1.2	2.7	19.9	1.5	14.8	3.9	24.1	1.7	
	6.7	2.0	4.5	27.3	16.9	0.7	29.9	36.9	38.9	1.1	6.7	2.0	4.5	20.4	1.5	15.3	4.0	25.4	1.8	
40	3.4	0.5	1.2	31.8	20.9	0.9	35.0	34.7	60.9	1.4	3.4	0.5	1.2	22.1	1.5	17.0	4.3	29.9	1.8	
	5.0	1.1	2.5	31.1	20.1	0.8	34.0	37.0	53.5	1.4	5.0	1.1	2.5	23.3	1.5	18.1	4.5	32.8	1.8	
	6.7	1.8	4.1	30.5	19.5	0.8	33.2	37.7	49.9	1.3	6.7	1.8	4.1	23.9	1.5	18.7	4.6	34.4	1.9	
50	3.4	0.5	1.1	31.8	21.4	1.1	35.4	30.3	71.2	1.3	3.4	0.5	1.1	25.2	1.5	20.0	4.8	38.1	1.9	
	5.0	1.0	2.3	32.0	21.2	1.0	35.2	33.5	64.0	1.3	5.0	1.0	2.3	26.5	1.6	21.2	5.0	41.6	1.9	
	6.7	1.6	3.8	31.8	20.9	0.9	34.9	34.9	60.4	1.2	6.7	1.6	3.8	27.2	1.6	21.9	5.1	43.5	2.0	
60	3.4	0.5	1.1	30.9	21.3	1.2	35.1	25.6	80.9	1.4	3.4	0.5	1.1	28.2	1.6	22.9	5.3	46.3	2.0	
	5.0	0.9	2.1	31.7	21.5	1.1	35.4	28.9	74.1	1.4	5.0	0.9	2.1	29.6	1.6	24.3	5.5	50.4	2.1	
	6.7	1.5	3.6	31.9	21.4	1.0	35.4	30.6	70.6	1.3	6.7	1.5	3.6	30.4	1.6	25.0	5.6	52.5	2.2	
70	3.4	0.5	1.0	29.5	20.8	1.4	34.2	21.3	90.4	1.8	3.4	0.5	1.0	31.1	1.6	25.7	5.7	54.6	2.3	
	5.0	0.9	2.1	30.5	21.2	1.3	34.8	24.3	83.9	1.7	5.0	0.9	2.1	32.7	1.6	27.2	6.0	59.2	2.3	
	6.7	1.5	3.4	31.0	21.3	1.2	35.1	25.9	80.5	1.7	6.7	1.5	3.4	33.6	1.6	28.1	6.1	61.6	2.4	
80	3.4	0.4	1.0	27.7	20.1	1.6	33.1	17.5	99.8	2.4	3.4	0.4	1.0	34.0	1.6	28.5	6.2	63.0	2.5	
	5.0	0.9	2.0	28.9	20.6	1.4	33.9	20.0	93.5	2.3	5.0	0.9	2.0	35.7	1.6	30.2	6.4	68.0	2.6	
	6.7	1.4	3.3	29.5	20.8	1.4	34.2	21.4	90.2	2.3	6.7	1.4	3.3	36.7	1.6	31.1	6.5	70.7	2.7	
85	3.4	0.4	1.0	26.8	19.7	1.7	32.5	15.9	104.4	2.9	3.4	0.4	1.0	35.5	1.6	29.9	6.4	67.2	2.6	
	5.0	0.9	2.0	28.0	20.2	1.5	33.3	18.1	98.2	2.8	5.0	0.9	2.0	37.3	1.6	31.6	6.6	72.4	2.7	
	6.7	1.4	3.3	28.6	20.5	1.5	33.7	19.4	95.1	2.6	6.7	1.4	3.3	38.2	1.7	32.6	6.8	75.3	2.8	
90	3.4	0.4	1.0	25.8	19.2	1.8	31.9	14.4	109.1	3.3	3.4	0.4	1.0	36.9	1.6	31.3	6.6	71.3	2.8	
	5.0	0.9	2.0	27.0	19.8	1.7	32.7	16.4	103.0	3.2	5.0	0.9	2.0	38.8	1.7	33.1	6.8	76.8	2.9	
	6.7	1.4	3.2	27.7	20.1	1.6	33.1	17.5	99.9	3.1	6.7	1.4	3.2	39.8	1.7	34.1	7.0	79.8	3.0	
100	3.4	0.4	1.0	24.0	18.5	2.0	30.9	11.8	118.5	4.4	Operation Not Recommended									
	5.0	0.8	1.9	25.1	19.0	1.9	31.5	13.3	112.5	4.3										
	6.7	1.4	3.2	25.7	19.2	1.8	31.9	14.2	109.5	4.1										
110	3.4	0.4	1.0	22.4	18.0	2.3	30.3	9.7	128.1	5.7										
	5.0	0.8	1.9	23.3	18.3	2.1	30.6	10.9	122.2	5.6										
	6.7	1.3	3.1	23.8	18.5	2.1	30.9	11.6	119.2	5.4										
120	3.4	0.4	1.0	21.4	18.1	2.6	30.3	8.2	138.1	7.3										
	5.0	0.8	1.8	22.0	18.0	2.4	30.2	9.1	132.0	7.1										
	6.7	1.3	3.0	22.3	18.0	2.3	30.3	9.6	129.0	6.9										

- Interpolation is permissible; extrapolation is not.
- All entering air conditions are 80°F (26.6°C) DB and 67°F (19.4°C) WB in cooling, and 70°F (21°C) DB in heating.
- AHRI/ISO certified conditions are 80.6°F (27°C) DB and 66.2°F (19°C) WB in cooling and 68°F (20°C) DB in heating.
- Table does not reflect fan or pump power corrections for AHRI/ISO conditions.
- All performance is based upon the lower voltage of dual voltage rated units.
- Performance stated is at the rated power supply; performance may vary as the power supply varies from the rated.
- Operation below 40°F (10.0°C) EWT is based upon 20% methanol antifreeze solution.
- Operation below 60°F (15.5°C) EWT requires optional insulated water/refrigerant circuit.
- See performance correction tables for operating conditions other than those listed above.
- See Performance Data Selection Notes for operation in the shaded areas.
- Regular Cooling operation with an EWT of less than 50°F (10.0°C) is not recommended unless variable water flow is available.
- Regular Heating operation with an EWT of more than 90°F (32°C) is not recommended unless variable water flow is available.
- For quiet operation and long term reliability, it is recommended that systems be designed to avoid continuous operation in the outlined areas.
- Performance capacities shown in thousands of Btuh
- Hot Water Generator Capacity is based on 90°F entering water and 0.5 GPM/Ton.

Heat Controller works continually to improve its products. As a result, the design and specifications of each product at the time of order may be changed without notice and may not be as described herein. Please contact Heat Controller's Customer Service Department at 517-787-2100 for specific information on the current design and specifications. Statements and other information contained herein are not express warranties and do not form the basis of any bargain between the parties, but are merely Heat Controller's opinion or commendation of its products. The latest version of this document is available at www.heatcontroller.com. Engineered and assembled in the USA. © Heat Controller, Inc. All Rights Reserved 2024

Performance Data ME036 EC Blower Motor (Full Load)

Models:
ME
024-072

1,200 CFM Rated Airflow

EWT °F	WPD			Cooling - EAT 80/67°F							WPD			Heating - EAT 70°F						
	FLOW GPM	PSI	FT	TC	SC	kW	HR	EER	LWT	HWG Cap	FLOW GPM	PSI	FT	HC	kW	HE	COP	LWT	HWG Cap	
20	6.8	Operation Not Recommended										9.0	3.7	8.5	23.9	1.9	17.3	3.6	16.2	2.0
	9.0																			
30	4.5	1.0	2.3	40.1	24.7	1.4	45.0	28.3	50.0	1.1	4.5	1.0	2.3	26.7	2.0	19.9	3.9	21.2	2.5	
	6.8	2.0	4.7	37.3	22.5	1.3	41.8	28.2	42.4	1.0	6.8	2.0	4.7	28.1	2.0	21.2	4.1	23.7	2.7	
	9.0	3.2	7.5	35.6	21.3	1.3	39.9	27.9	38.9	0.9	9.0	3.2	7.5	28.8	2.0	21.9	4.1	25.1	3.0	
40	4.5	0.9	2.1	42.3	26.7	1.6	47.7	26.8	61.2	1.3	4.5	0.9	2.1	31.1	2.1	24.0	4.4	29.4	3.0	
	6.8	1.8	4.2	41.1	25.5	1.5	46.1	27.9	53.7	1.1	6.8	1.8	4.2	32.7	2.1	25.5	4.5	32.5	3.3	
	9.0	2.9	6.8	40.1	24.7	1.4	45.0	28.3	50.0	1.0	9.0	2.9	6.8	33.5	2.1	26.3	4.6	34.2	3.6	
50	4.5	0.8	1.9	42.5	27.3	1.7	48.5	24.4	71.6	1.6	4.5	0.8	1.9	35.3	2.2	27.9	4.8	37.6	3.5	
	6.8	1.6	3.8	42.5	27.0	1.6	48.1	26.1	64.2	1.5	6.8	1.6	3.8	37.1	2.2	29.6	4.9	41.2	3.8	
	9.0	2.7	6.2	42.2	26.6	1.6	47.6	26.9	60.6	1.4	9.0	2.7	6.2	38.1	2.2	30.5	5.0	43.2	4.2	
60	4.5	0.8	1.8	41.6	27.2	1.9	48.2	21.6	81.4	2.2	4.5	0.8	1.8	39.4	2.3	31.7	5.1	45.9	4.0	
	6.8	1.5	3.5	42.4	27.4	1.8	48.5	23.6	74.4	2.0	6.8	1.5	3.5	41.4	2.3	33.5	5.2	50.1	4.4	
	9.0	2.5	5.9	42.6	27.3	1.7	48.5	24.6	70.8	1.8	9.0	2.5	5.9	42.5	2.3	34.5	5.3	52.3	4.8	
70	4.5	0.7	1.7	39.9	26.5	2.1	47.1	18.8	90.9	3.0	4.5	0.7	1.7	43.5	2.4	35.4	5.4	54.3	4.5	
	6.8	1.5	3.4	41.2	27.0	2.0	47.9	20.8	84.2	2.7	6.8	1.5	3.4	45.7	2.4	37.4	5.5	58.9	5.0	
	9.0	2.4	5.6	41.7	27.2	1.9	48.2	21.8	80.7	2.5	9.0	2.4	5.6	46.8	2.5	38.4	5.6	61.5	5.4	
80	4.5	0.7	1.7	37.7	25.5	2.3	45.7	16.1	100.3	3.9	4.5	0.7	1.7	47.4	2.5	38.9	5.6	62.7	5.0	
	6.8	1.4	3.3	39.2	26.2	2.2	46.7	17.9	93.8	3.6	6.8	1.4	3.3	49.8	2.6	41.1	5.7	67.8	5.5	
	9.0	2.4	5.5	40.0	26.6	2.1	47.2	18.9	90.5	3.3	9.0	2.4	5.5	51.1	2.6	42.2	5.8	70.6	6.0	
85	4.5	0.7	1.7	36.5	24.9	2.5	44.9	14.9	105.0	4.4	4.5	0.7	1.7	49.4	2.5	40.7	5.7	66.9	5.3	
	6.8	1.4	3.3	38.1	25.7	2.3	46.0	16.6	98.6	4.1	6.8	1.4	3.3	51.9	2.6	42.9	5.8	72.3	5.8	
	9.0	2.4	5.4	38.9	26.1	2.2	46.5	17.5	95.3	3.8	9.0	2.4	5.4	53.2	2.7	44.1	5.9	75.2	6.3	
90	4.5	0.7	1.7	35.4	24.3	2.6	44.2	13.7	109.6	5.1	4.5	0.7	1.7	51.3	2.6	42.5	5.8	71.1	5.6	
	6.8	1.4	3.3	36.9	25.1	2.4	45.2	15.3	103.4	4.6	6.8	1.4	3.3	53.9	2.7	44.8	5.9	76.7	6.1	
	9.0	2.3	5.4	37.8	25.5	2.3	45.7	16.2	100.2	4.2	9.0	2.3	5.4	55.3	2.7	46.0	5.9	79.8	6.7	
100	4.5	0.7	1.6	33.1	23.2	2.9	42.9	11.5	119.1	6.4	Operation Not Recommended									
	6.8	1.4	3.2	34.5	23.9	2.7	43.7	12.9	112.9	5.9										
	9.0	2.3	5.3	35.3	24.3	2.6	44.2	13.6	109.8	5.3										
110	4.5	0.7	1.6	31.2	22.3	3.2	42.0	9.8	128.7	7.9										
	6.8	1.4	3.2	32.3	22.8	3.0	42.5	10.8	122.6	7.3										
	9.0	2.2	5.1	33.0	23.1	2.9	42.8	11.4	119.5	6.6										
120	4.5	0.7	1.5	29.9	22.0	3.6	42.1	8.4	138.7	9.7										
	6.8	1.3	3.0	30.6	22.1	3.3	41.9	9.2	132.4	8.9										
	9.0	2.1	4.9	31.1	22.3	3.2	42.0	9.7	129.3	8.1										

- Interpolation is permissible; extrapolation is not.
- All entering air conditions are 80°F (26.6°C) DB and 67°F (19.4°C) WB in cooling, and 70°F (21°C) DB in heating.
- AHRI/ISO certified conditions are 80.6°F (27°C) DB and 66.2°F (19°C) WB in cooling and 68°F (20°C) DB in heating.
- Table does not reflect fan or pump power corrections for AHRI/ISO conditions.
- All performance is based upon the lower voltage of dual voltage rated units.
- Performance stated is at the rated power supply; performance may vary as the power supply varies from the rated.
- Operation below 40°F (10.0°C) EWT is based upon 20% methanol antifreeze solution.
- Operation below 60°F (15.5°C) EWT requires optional insulated water/refrigerant circuit.
- See performance correction tables for operating conditions other than those listed above.
- See Performance Data Selection Notes for operation in the shaded areas.
- Regular Cooling operation with an EWT of less than 50°F (10.0°C) is not recommended unless variable water flow is available.
- Regular Heating operation with an EWT of more than 90°F (32°C) is not recommended unless variable water flow is available.
- For quiet operation and long term reliability, it is recommended that systems be designed to avoid continuous operation in the outlined areas.
- Performance capacities shown in thousands of Btuh
- Hot Water Generator Capacity is based on 90°F entering water and 0.5 GPM/Ton.

Heat Controller works continually to improve its products. As a result, the design and specifications of each product at the time of order may be changed without notice and may not be as described herein. Please contact Heat Controller's Customer Service Department at 517-787-2100 for specific information on the current design and specifications. Statements and other information contained herein are not express warranties and do not form the basis of any bargain between the parties, but are merely Heat Controller's opinion or commendation of its products. The latest version of this document is available at www.heatcontroller.com. Engineered and assembled in the USA. © Heat Controller, Inc. All Rights Reserved 2024

Performance Data ME036 EC Blower Motor Modulating Flow (Part Load)

Models:
ME
024-072

1100 CFM Rated Airflow

EWT °F	WPD			COOLING - EAT 80/67 °F							WPD			HEATING - EAT 70°F					
	FLOW GPM	PSI	FT	TC	SC	kW	HR	EER	LWT	HWG Cap	FLOW GPM	PSI	FT	HC	kW	HE	COP	LWT	HWG Cap
20	5.0	Operation Not Recommended																	
	6.7										6.7	2.2	5.0	16.7	1.5	11.7	3.3	16.5	1.6
30	3.4	0.2	0.4	33.4	21.9	0.9	36.3	38.3	60.0	1.1	3.4	0.6	1.4	18.9	1.5	13.8	3.7	21.7	1.7
	5.0	0.2	0.4	33.4	21.9	0.9	36.3	38.3	60.0	1.1	5.0	1.2	2.7	19.9	1.5	14.8	3.9	24.1	1.7
	6.7	0.2	0.4	33.4	21.9	0.9	36.3	38.3	60.0	1.1	6.7	2.0	4.5	20.4	1.5	15.3	4.0	25.4	1.8
40	3.4	0.6	1.3	31.8	20.8	0.9	34.9	35.0	60.0	1.1	3.4	0.5	1.2	22.1	1.5	17.0	4.3	29.9	1.8
	5.0	0.6	1.3	31.8	20.8	0.9	34.9	35.0	60.0	1.1	5.0	1.1	2.5	23.3	1.5	18.1	4.5	32.8	1.8
	6.7	0.6	1.3	31.8	20.8	0.9	34.9	35.0	60.0	1.1	6.7	1.8	4.1	23.9	1.5	18.7	4.6	34.4	1.9
50	3.4	0.5	1.1	31.8	21.4	1.1	35.4	30.3	71.2	1.3	3.4	0.5	1.1	25.2	1.5	20.0	4.8	38.1	1.9
	5.0	1.0	2.3	32.0	21.2	1.0	35.2	33.5	64.0	1.3	5.0	1.0	2.3	26.5	1.6	21.2	5.0	41.6	1.9
	6.7	1.6	3.8	31.8	20.9	0.9	34.9	34.9	60.4	1.2	6.7	1.6	3.8	27.2	1.6	21.9	5.1	43.5	2.0
60	3.4	0.5	1.1	30.9	21.3	1.2	35.1	25.6	80.9	1.4	3.4	0.5	1.1	28.2	1.6	22.9	5.3	46.3	2.0
	5.0	0.9	2.1	31.7	21.5	1.1	35.4	28.9	74.1	1.4	5.0	0.9	2.1	29.6	1.6	24.3	5.5	50.4	2.1
	6.7	1.5	3.6	31.9	21.4	1.0	35.4	30.6	70.6	1.3	6.7	1.5	3.6	30.4	1.6	25.0	5.6	52.5	2.2
70	3.4	0.5	1.0	29.5	20.8	1.4	34.2	21.3	90.4	1.8	3.4	0.5	1.0	31.1	1.6	25.7	5.7	54.6	2.3
	5.0	0.9	2.1	30.5	21.2	1.3	34.8	24.3	83.9	1.7	5.0	0.9	2.1	32.7	1.6	27.2	6.0	59.2	2.3
	6.7	1.5	3.4	31.0	21.3	1.2	35.1	25.9	80.5	1.7	6.7	1.5	3.4	33.6	1.6	28.1	6.1	61.6	2.4
80	3.4	0.4	1.0	27.7	20.1	1.6	33.1	17.5	99.8	2.4	3.4	0.4	1.0	34.0	1.6	28.5	6.2	63.0	2.5
	5.0	0.9	2.0	28.9	20.6	1.4	33.9	20.0	93.5	2.3	5.0	0.9	2.0	35.7	1.6	30.2	6.4	68.0	2.6
	6.7	1.4	3.3	29.5	20.8	1.4	34.2	21.4	90.2	2.3	6.7	1.4	3.3	36.7	1.6	31.1	6.5	70.7	2.7
85	3.4	0.4	1.0	26.8	19.7	1.7	32.5	15.9	104.4	2.9	3.4	0.4	1.0	35.5	1.6	29.9	6.4	67.2	2.6
	5.0	0.9	2.0	28.0	20.2	1.5	33.3	18.1	98.2	2.8	5.0	0.9	2.0	37.3	1.6	31.6	6.6	72.4	2.7
	6.7	1.4	3.3	28.6	20.5	1.5	33.7	19.4	95.1	2.6	6.7	1.4	3.3	38.2	1.7	32.6	6.8	75.3	2.8
90	3.4	0.4	1.0	25.8	19.2	1.8	31.9	14.4	109.1	3.3	3.4	0.4	1.0	36.9	1.6	31.3	6.6	71.3	2.8
	5.0	0.9	2.0	27.0	19.8	1.7	32.7	16.4	103.0	3.2	5.0	0.9	2.0	38.8	1.7	33.1	6.8	76.8	2.9
	6.7	1.4	3.2	27.7	20.1	1.6	33.1	17.5	99.9	3.1	6.7	1.4	3.2	39.8	1.7	34.1	7.0	79.8	3.0
100	3.4	0.4	1.0	24.0	18.5	2.0	30.9	11.8	118.5	4.4	2.1	0.1	0.2	36.4	1.6	30.8	6.5	70.0	2.8
	5.0	0.8	1.9	25.1	19.0	1.9	31.5	13.3	112.5	4.3	2.1	0.1	0.2	36.4	1.6	30.8	6.5	70.0	2.8
	6.7	1.4	3.2	25.7	19.2	1.8	31.9	14.2	109.5	4.1	2.1	0.1	0.2	36.4	1.6	30.8	6.5	70.0	2.8
110	3.4	0.4	1.0	22.4	18.0	2.3	30.3	9.7	128.1	5.7	1.5	0.1	0.2	36.4	1.6	30.8	6.5	70.0	2.8
	5.0	0.8	1.9	23.3	18.3	2.1	30.6	10.9	122.2	5.6	1.5	0.1	0.2	36.4	1.6	30.8	6.5	70.0	2.8
	6.7	1.3	3.1	23.8	18.5	2.1	30.9	11.6	119.2	5.4	1.5	0.1	0.2	36.4	1.6	30.8	6.5	70.0	2.8
120	3.4	0.4	1.0	21.4	18.1	2.6	30.3	8.2	138.1	7.3	1.2	0.1	0.2	36.4	1.6	30.8	6.5	70.0	2.8
	5.0	0.8	1.8	22.0	18.0	2.4	30.2	9.1	132.0	7.1	1.2	0.1	0.2	36.4	1.6	30.8	6.5	70.0	2.8
	6.7	1.3	3.0	22.3	18.0	2.3	30.3	9.6	129.0	6.9	1.2	0.1	0.2	36.4	1.6	30.8	6.5	70.0	2.8

- Interpolation is permissible; extrapolation is not.
- All entering air conditions are 80°F (26.6°C) DB and 67°F (19.4°C) WB in cooling, and 70°F (21°C) DB in heating.
- AHRI/ISO certified conditions are 80.6°F (27°C) DB and 66.2°F (19°C) WB in cooling and 68°F (20°C) DB in heating.
- Table does not reflect fan or pump power corrections for AHRI/ISO conditions.
- All performance is based upon the lower voltage of dual voltage rated units.
- Performance stated is at the rated power supply; performance may vary as the power supply varies from the rated.
- Operation below 40°F (10.0°C) EWT is based upon 20% methanol antifreeze solution.
- Operation below 60°F (15.5°C) EWT requires optional insulated water/refrigerant circuit.
- See performance correction tables for operating conditions other than those listed above.
- See Performance Data Selection Notes for operation in the shaded areas.
- Regular Cooling operation with an EWT of less than 50°F (10.0°C) is not recommended unless variable water flow is available.
- Regular Heating operation with an EWT of more than 90°F (32°C) is not recommended unless variable water flow is available.
- For quiet operation and long term reliability, it is recommended that systems be designed to avoid continuous operation in the outlined areas.
- Performance capacities shown in thousands of Btuh
- Hot Water Generator Capacity is based on 90°F entering water and 0.5 GPM/Ton.

Heat Controller works continually to improve its products. As a result, the design and specifications of each product at the time of order may be changed without notice and may not be as described herein. Please contact Heat Controller's Customer Service Department at 517-787-2100 for specific information on the current design and specifications. Statements and other information contained herein are not express warranties and do not form the basis of any bargain between the parties, but are merely Heat Controller's opinion or commendation of its products. The latest version of this document is available at www.heatcontroller.com. Engineered and assembled in the USA. © Heat Controller, Inc. All Rights Reserved 2024

ME036 EC Blower Motor Modulating Flow (Full Load)

Models:
ME
024-072

1200 CFM Rated Airflow

EWT °F	WPD			COOLING - EAT 80/67 °F							WPD			HEATING - EAT 70°F					
	FLOW GPM	PSI	FT	TC	SC	kW	HR	EER	LWT	HWG Cap	FLOW GPM	PSI	FT	HC	kW	HE	COP	LWT	HWG Cap
20	6.8	Operation Not Recommended																	
	9.0										9.0	3.7	8.5	23.9	1.9	17.3	3.6	16.2	2.0
30	3.3	0.4	0.9	44.2	27.8	1.5	49.5	28.5	60.0	1.1	4.5	1.0	2.3	26.7	2.0	19.9	3.9	21.2	2.5
	3.3	0.4	0.9	44.2	27.8	1.5	49.5	28.5	60.0	1.1	6.8	2.0	4.7	28.1	2.0	21.2	4.1	23.7	2.7
	3.3	0.4	0.9	44.2	27.8	1.5	49.5	28.5	60.0	1.1	9.0	3.2	7.5	28.8	2.0	21.9	4.1	25.1	3.0
40	4.7	1.0	2.2	42.1	26.5	1.6	47.4	27.0	60.0	1.1	4.5	0.9	2.1	31.1	2.1	24.0	4.4	29.4	3.0
	4.7	1.0	2.2	42.1	26.5	1.6	47.4	27.0	60.0	1.1	6.8	1.8	4.2	32.7	2.1	25.5	4.5	32.5	3.3
	4.7	1.0	2.2	42.1	26.5	1.6	47.4	27.0	60.0	1.1	9.0	2.9	6.8	33.5	2.1	26.3	4.6	34.2	3.6
50	4.5	0.8	1.9	42.5	27.3	1.7	48.5	24.4	71.6	1.6	4.5	0.8	1.9	35.3	2.2	27.9	4.8	37.6	3.5
	6.8	1.6	3.8	42.5	27.0	1.6	48.1	26.1	64.2	1.5	6.8	1.6	3.8	37.1	2.2	29.6	4.9	41.2	3.8
	9.0	2.7	6.2	42.2	26.6	1.6	47.6	26.9	60.6	1.4	9.0	2.7	6.2	38.1	2.2	30.5	5.0	43.2	4.2
60	4.5	0.8	1.8	41.6	27.2	1.9	48.2	21.6	81.4	2.2	4.5	0.8	1.8	39.4	2.3	31.7	5.1	45.9	4.0
	6.8	1.5	3.5	42.4	27.4	1.8	48.5	23.6	74.4	2.0	6.8	1.5	3.5	41.4	2.3	33.5	5.2	50.1	4.4
	9.0	2.5	5.9	42.6	27.3	1.7	48.5	24.6	70.8	1.8	9.0	2.5	5.9	42.5	2.3	34.5	5.3	52.3	4.8
70	4.5	0.7	1.7	39.9	26.5	2.1	47.1	18.8	90.9	3.0	4.5	0.7	1.7	43.5	2.4	35.4	5.4	54.3	4.5
	6.8	1.5	3.4	41.2	27.0	2.0	47.9	20.8	84.2	2.7	6.8	1.5	3.4	45.7	2.4	37.4	5.5	58.9	5.0
	9.0	2.4	5.6	41.7	27.2	1.9	48.2	21.8	80.7	2.5	9.0	2.4	5.6	46.8	2.5	38.4	5.6	61.5	5.4
80	4.5	0.7	1.7	37.7	25.5	2.3	45.7	16.1	100.3	3.9	4.5	0.7	1.7	47.4	2.5	38.9	5.6	62.7	5.0
	6.8	1.4	3.3	39.2	26.2	2.2	46.7	17.9	93.8	3.6	6.8	1.4	3.3	49.8	2.6	41.1	5.7	67.8	5.5
	9.0	2.4	5.5	40.0	26.6	2.1	47.2	18.9	90.5	3.3	9.0	2.4	5.5	51.1	2.6	42.2	5.8	70.6	6.0
85	4.5	0.7	1.7	36.5	24.9	2.5	44.9	14.9	105.0	4.4	4.5	0.7	1.7	49.4	2.5	40.7	5.7	66.9	5.3
	6.8	1.4	3.3	38.1	25.7	2.3	46.0	16.6	98.6	4.1	6.8	1.4	3.3	51.9	2.6	42.9	5.8	72.3	5.8
	9.0	2.4	5.4	38.9	26.1	2.2	46.5	17.5	95.3	3.8	9.0	2.4	5.4	53.2	2.7	44.1	5.9	75.2	6.3
90	4.5	0.7	1.7	35.4	24.3	2.6	44.2	13.7	109.6	5.1	4.2	0.1	0.2	50.8	2.6	42.0	5.8	70.0	6.3
	6.8	1.4	3.3	36.9	25.1	2.4	45.2	15.3	103.4	4.6	4.2	0.1	0.2	50.8	2.6	42.0	5.8	70.0	6.3
	9.0	2.3	5.4	37.8	25.5	2.3	45.7	16.2	100.2	4.2	4.2	0.1	0.2	50.8	2.6	42.0	5.8	70.0	6.3
100	4.5	0.7	1.6	33.1	23.2	2.9	42.9	11.5	119.1	6.4	2.8	0.1	0.2	50.8	2.6	42.0	5.8	70.0	6.3
	6.8	1.4	3.2	34.5	23.9	2.7	43.7	12.9	112.9	5.9	2.8	0.1	0.2	50.8	2.6	42.0	5.8	70.0	6.3
	9.0	2.3	5.3	35.3	24.3	2.6	44.2	13.6	109.8	5.3	2.8	0.1	0.2	50.8	2.6	42.0	5.8	70.0	6.3
110	4.5	0.7	1.6	31.2	22.3	3.2	42.0	9.8	128.7	7.9	2.1	0.1	0.2	50.8	2.6	42.0	5.8	70.0	6.3
	6.8	1.4	3.2	32.3	22.8	3.0	42.5	10.8	122.6	7.3	2.1	0.1	0.2	50.8	2.6	42.0	5.8	70.0	6.3
	9.0	2.2	5.1	33.0	23.1	2.9	42.8	11.4	119.5	6.6	2.1	0.1	0.2	50.8	2.6	42.0	5.8	70.0	6.3
120	4.5	0.7	1.5	29.9	22.0	3.6	42.1	8.4	138.7	9.7	1.7	0.1	0.2	50.8	2.6	42.0	5.8	70.0	6.3
	6.8	1.3	3.0	30.6	22.1	3.3	41.9	9.2	132.4	8.9	1.7	0.1	0.2	50.8	2.6	42.0	5.8	70.0	6.3
	9.0	2.1	4.9	31.1	22.3	3.2	42.0	9.7	129.3	8.1	1.7	0.1	0.2	50.8	2.6	42.0	5.8	70.0	6.3

- Interpolation is permissible; extrapolation is not.
- All entering air conditions are 80°F (26.6°C) DB and 67°F (19.4°C) WB in cooling, and 70°F (21°C) DB in heating.
- AHRI/ISO certified conditions are 80.6°F (27°C) DB and 66.2°F (19°C) WB in cooling and 68°F (20°C) DB in heating.
- Table does not reflect fan or pump power corrections for AHRI/ISO conditions.
- All performance is based upon the lower voltage of dual voltage rated units.
- Performance stated is at the rated power supply; performance may vary as the power supply varies from the rated.
- Operation below 40°F (10.0°C) EWT is based upon 20% methanol antifreeze solution.
- Operation below 60°F (15.5°C) EWT requires optional insulated water/refrigerant circuit.
- See performance correction tables for operating conditions other than those listed above.
- See Performance Data Selection Notes for operation in the shaded areas.
- Regular Cooling operation with an EWT of less than 50°F (10.0°C) is not recommended unless variable water flow is available.
- Regular Heating operation with an EWT of more than 90°F (32°C) is not recommended unless variable water flow is available.
- For quiet operation and long term reliability, it is recommended that systems be designed to avoid continuous operation in the outlined areas.
- Performance capacities shown in thousands of Btuh
- Hot Water Generator Capacity is based on 90°F entering water and 0.5 GPM/Ton.

Heat Controller works continually to improve its products. As a result, the design and specifications of each product at the time of order may be changed without notice and may not be as described herein. Please contact Heat Controller's Customer Service Department at 517-787-2100 for specific information on the current design and specifications. Statements and other information contained herein are not express warranties and do not form the basis of any bargain between the parties, but are merely Heat Controller's opinion or commendation of its products. The latest version of this document is available at www.heatcontroller.com. Engineered and assembled in the USA. © Heat Controller, Inc. All Rights Reserved 2024

Performance Data ME048 EC Blower Motor (Part Load)

Models:
ME
024-072

1,500 CFM Rated Airflow

EWT °F	WPD			Cooling - EAT 80/67°F							WPD			Heating - EAT 70°F						
	FLOW GPM	PSI	FT	TC	SC	kW	HR	EER	LWT	HWG Cap	FLOW GPM	PSI	FT	HC	kW	HE	COP	LWT	HWG Cap	
20	6.9	Operation Not Recommended										9.2	2.1	4.9	23.1	2.2	15.7	3.1	16.6	2.4
	9.2																			
30	4.6	0.7	1.6	40.2	26.6	1.1	43.9	36.2	49.1	1.3	4.6	0.7	1.6	25.4	2.2	18.1	3.5	22.1	2.6	
	6.9	1.3	2.9	38.4	24.3	1.0	41.9	37.0	42.1	1.2	6.9	1.3	2.9	26.4	2.2	19.1	3.6	24.5	2.7	
	9.2	2.0	4.6	37.3	23.0	1.0	40.7	36.8	38.9	1.2	9.2	2.0	4.6	27.0	2.2	19.6	3.7	25.7	2.8	
40	4.6	0.6	1.5	41.5	28.9	1.3	45.8	32.8	59.9	1.3	4.6	0.6	1.5	29.2	2.2	21.9	4.0	30.5	2.9	
	6.9	1.2	2.7	40.8	27.6	1.2	44.8	35.2	53.0	1.2	6.9	1.2	2.7	30.6	2.2	23.2	4.1	33.3	3.0	
	9.2	1.9	4.3	40.2	26.7	1.1	44.1	36.1	49.6	1.2	9.2	1.9	4.3	31.3	2.2	23.9	4.2	34.8	3.0	
50	4.6	0.6	1.4	41.5	29.8	1.5	46.4	28.5	70.2	1.5	4.6	0.6	1.4	33.3	2.2	25.9	4.5	38.8	3.1	
	6.9	1.1	2.6	41.6	29.3	1.3	46.2	31.4	63.4	1.5	6.9	1.1	2.6	34.9	2.2	27.5	4.7	42.0	3.2	
	9.2	1.8	4.1	41.5	28.9	1.3	45.8	32.8	60.0	1.5	9.2	1.8	4.1	35.9	2.2	28.4	4.8	43.8	3.3	
60	4.6	0.6	1.4	40.4	29.8	1.7	46.1	24.0	80.0	2.0	4.6	0.6	1.4	37.5	2.2	30.0	5.0	46.9	3.4	
	6.9	1.1	2.5	41.2	29.9	1.5	46.4	27.0	73.5	1.9	6.9	1.1	2.5	39.5	2.2	32.0	5.3	50.7	3.5	
	9.2	1.7	3.9	41.5	29.8	1.5	46.4	28.5	70.1	1.8	9.2	1.7	3.9	40.6	2.2	33.0	5.4	52.8	3.7	
70	4.6	0.6	1.3	38.5	29.0	1.9	45.1	20.0	89.6	2.5	4.6	0.6	1.3	41.8	2.2	34.2	5.5	55.1	3.8	
	6.9	1.1	2.4	39.8	29.6	1.8	45.8	22.6	83.3	2.5	6.9	1.1	2.4	44.0	2.2	36.5	5.8	59.4	3.9	
	9.2	1.7	3.9	40.4	29.8	1.7	46.1	24.0	80.0	2.4	9.2	1.7	3.9	45.3	2.2	37.7	6.0	61.8	4.0	
80	4.6	0.6	1.3	36.1	27.8	2.2	43.6	16.4	99.0	3.3	4.6	0.6	1.3	46.0	2.2	38.4	6.1	63.3	4.2	
	6.9	1.0	2.4	37.7	28.6	2.0	44.6	18.6	92.9	3.2	6.9	1.0	2.4	48.5	2.2	40.9	6.4	68.2	4.3	
	9.2	1.7	3.8	38.5	29.0	1.9	45.1	19.9	89.8	3.1	9.2	1.7	3.8	49.9	2.2	42.2	6.5	70.8	4.4	
85	4.6	0.6	1.3	34.8	27.2	2.3	42.8	14.8	103.6	4.0	4.6	0.6	1.3	48.1	2.2	40.5	6.3	67.4	4.3	
	6.9	1.0	2.4	36.5	28.0	2.2	43.8	16.8	97.7	3.8	6.9	1.0	2.4	50.7	2.2	43.0	6.6	72.5	4.4	
	9.2	1.6	3.8	37.3	28.4	2.1	44.3	18.0	94.6	3.5	9.2	1.6	3.8	52.1	2.3	44.4	6.8	75.3	4.6	
90	4.6	0.6	1.3	33.3	26.4	2.5	41.9	13.3	108.2	4.2	4.6	0.6	1.3	50.2	2.2	42.5	6.6	71.5	4.6	
	6.9	1.0	2.4	35.1	27.3	2.3	43.0	15.2	102.5	4.1	6.9	1.0	2.4	52.8	2.3	45.1	6.9	76.9	4.7	
	9.2	1.6	3.8	36.0	27.8	2.2	43.5	16.2	99.5	4.0	9.2	1.6	3.8	54.2	2.3	46.5	7.0	79.9	4.8	
100	4.6	0.6	1.4	30.4	25.0	2.8	40.0	10.8	117.4	5.3	Operation Not Recommended									
	6.9	1.0	2.4	32.2	25.8	2.6	41.1	12.2	111.9	5.2										
	9.2	1.6	3.7	33.1	26.3	2.5	41.7	13.1	109.1	5.0										
110	4.6	0.6	1.3	27.3	23.5	3.2	38.1	8.6	126.6	6.6										
	6.9	1.0	2.4	29.0	24.3	3.0	39.2	9.8	121.3	6.4										
	9.2	1.6	3.7	29.9	24.8	2.9	39.7	10.4	118.6	6.2										
120	4.6	0.6	1.3	24.3	22.2	3.5	36.3	6.9	135.8	8.0										
	6.9	1.0	2.3	25.9	22.9	3.3	37.3	7.8	130.8	7.8										
	9.2	1.6	3.6	26.7	23.3	3.2	37.8	8.3	128.2	7.5										

- Interpolation is permissible; extrapolation is not.
- All entering air conditions are 80°F (26.6°C) DB and 67°F (19.4°C) WB in cooling, and 70°F (21°C) DB in heating.
- AHRI/ISO certified conditions are 80.6°F (27°C) DB and 66.2°F (19°C) WB in cooling and 68°F (20°C) DB in heating.
- Table does not reflect fan or pump power corrections for AHRI/ISO conditions.
- All performance is based upon the lower voltage of dual voltage rated units.
- Performance stated is at the rated power supply; performance may vary as the power supply varies from the rated.
- Operation below 40°F (10.0°C) EWT is based upon 20% methanol antifreeze solution.
- Operation below 60°F (15.5°C) EWT requires optional insulated water/refrigerant circuit.
- See performance correction tables for operating conditions other than those listed above.
- See Performance Data Selection Notes for operation in the shaded areas.
- Regular Cooling operation with an EWT of less than 50°F (10.0°C) is not recommended unless variable water flow is available.
- Regular Heating operation with an EWT of more than 90°F (32°C) is not recommended unless variable water flow is available.
- For quiet operation and long term reliability, it is recommended that systems be designed to avoid continuous operation in the outlined areas.
- Performance capacities shown in thousands of Btuh
- Hot Water Generator Capacity is based on 90°F entering water and 0.5 GPM/Ton.

Heat Controller works continually to improve its products. As a result, the design and specifications of each product at the time of order may be changed without notice and may not be as described herein. Please contact Heat Controller's Customer Service Department at 517-787-2100 for specific information on the current design and specifications. Statements and other information contained herein are not express warranties and do not form the basis of any bargain between the parties, but are merely Heat Controller's opinion or commendation of its products. The latest version of this document is available at www.heatcontroller.com. Engineered and assembled in the USA. © Heat Controller, Inc. All Rights Reserved 2024

Performance Data ME048 EC Blower Motor (Full Load)

Models:
ME
024-072

1,600 CFM Rated Airflow

EWT °F	WPD			Cooling - EAT 80/67°F							WPD			Heating - EAT 70°F						
	FLOW GPM	PSI	FT	TC	SC	kW	HR	EER	LWT	HWG Cap	FLOW GPM	PSI	FT	HC	kW	HE	COP	LWT	HWG Cap	
20	9.0																			
	12.0										12.0	3.4	7.8	34.0	3.0	23.9	3.4	16.0	3.2	
30	6.0	1.0	2.4	53.7	34.0	2.0	60.6	26.4	50.2	1.2	6.0	1.0	2.4	36.5	3.0	26.3	3.6	21.2	3.6	
	9.0	1.9	4.5	51.0	31.5	1.9	57.5	26.8	42.8	1.1	9.0	1.9	4.5	37.9	3.0	27.6	3.7	23.9	3.9	
	12.0	3.1	7.2	49.3	30.1	1.8	55.6	26.8	39.3	1.0	12.0	3.1	7.2	38.7	3.0	28.4	3.8	25.3	4.3	
40	6.0	0.9	2.2	55.7	36.4	2.2	63.3	24.8	61.1	1.7	6.0	0.9	2.2	41.3	3.1	30.9	4.0	29.7	4.0	
	9.0	1.8	4.2	54.6	34.9	2.1	61.7	26.0	53.7	1.5	9.0	1.8	4.2	43.2	3.1	32.6	4.1	32.7	4.3	
	12.0	2.9	6.7	53.7	34.0	2.0	60.6	26.4	50.1	1.4	12.0	2.9	6.7	44.2	3.1	33.6	4.2	34.4	4.5	
50	6.0	0.9	2.1	55.7	37.2	2.5	64.2	22.6	71.4	2.3	6.0	0.9	2.1	46.6	3.2	35.9	4.3	38.0	4.4	
	9.0	1.7	3.9	55.9	36.7	2.3	63.7	24.2	64.2	2.1	9.0	1.7	3.9	49.0	3.2	38.1	4.5	41.5	4.8	
	12.0	2.8	6.4	55.6	36.3	2.2	63.3	24.9	60.5	1.9	12.0	2.8	6.4	50.3	3.2	39.3	4.6	43.5	5.0	
60	6.0	0.9	2.0	54.5	37.1	2.7	63.7	20.1	81.2	3.1	6.0	0.9	2.0	52.3	3.3	41.1	4.7	46.3	4.8	
	9.0	1.6	3.8	55.5	37.3	2.5	64.1	21.9	74.3	2.8	9.0	1.6	3.8	55.1	3.3	43.7	4.8	50.3	5.3	
	12.0	2.7	6.2	55.8	37.2	2.4	64.1	22.8	70.7	2.6	12.0	2.7	6.2	56.6	3.4	45.1	4.9	52.5	5.7	
70	6.0	0.9	2.0	52.3	36.2	3.0	62.4	17.6	90.8	4.0	6.0	0.9	2.0	58.1	3.4	46.4	5.0	54.5	5.3	
	9.0	1.6	3.7	53.9	36.9	2.8	63.4	19.4	84.1	3.6	9.0	1.6	3.7	61.2	3.5	49.3	5.1	59.0	5.9	
	12.0	2.6	6.1	54.6	37.1	2.7	63.8	20.3	80.6	3.3	12.0	2.6	6.1	62.9	3.5	50.9	5.2	61.5	6.4	
80	6.0	0.8	2.0	49.4	34.8	3.3	60.6	15.1	100.2	5.0	6.0	0.8	2.0	63.8	3.5	51.6	5.3	62.8	5.9	
	9.0	1.6	3.7	51.4	35.8	3.1	61.9	16.8	93.8	4.6	9.0	1.6	3.7	67.1	3.6	54.7	5.4	67.8	6.5	
	12.0	2.6	6.0	52.4	36.3	3.0	62.5	17.7	90.4	4.2	12.0	2.6	6.0	68.8	3.7	56.3	5.5	70.6	7.1	
85	6.0	0.8	2.0	47.9	34.0	3.4	59.6	13.9	104.9	5.6	6.0	0.8	2.0	66.5	3.6	54.2	5.4	66.9	6.2	
	9.0	1.6	3.7	50.0	35.1	3.2	61.0	15.5	98.5	4.9	9.0	1.6	3.7	69.8	3.7	57.2	5.5	72.3	6.8	
	12.0	2.6	5.9	51.0	35.6	3.1	61.6	16.4	95.3	4.7	12.0	2.6	5.9	71.6	3.7	58.8	5.6	75.2	7.4	
90	6.0	0.8	2.0	46.3	33.2	3.6	58.6	12.8	109.5	6.2	6.0	0.8	2.0	69.1	3.7	56.6	5.5	71.1	6.5	
	9.0	1.6	3.7	48.4	34.3	3.4	60.0	14.3	103.3	5.7	9.0	1.6	3.7	72.4	3.8	59.6	5.6	76.8	7.1	
	12.0	2.6	5.9	49.5	34.9	3.3	60.6	15.1	100.1	5.1	12.0	2.6	5.9	74.1	3.8	61.1	5.7	79.8	7.8	
100	6.0	0.8	2.0	43.1	31.4	4.0	56.7	10.8	118.9	7.5										
	9.0	1.6	3.6	45.2	32.5	3.7	57.9	12.0	112.9	6.8										
	12.0	2.5	5.9	46.2	33.1	3.6	58.6	12.8	109.8	6.2										
110	6.0	0.8	1.9	40.0	29.7	4.4	55.2	9.0	128.4	8.9										
	9.0	1.6	3.6	41.9	30.7	4.2	56.1	10.1	122.5	8.2										
	12.0	2.5	5.8	42.9	31.3	4.0	56.6	10.7	119.4	7.4										
120	6.0	0.8	1.9	37.3	28.4	5.0	54.2	7.5	138.1	10.5										
	9.0	1.5	3.5	38.9	29.1	4.6	54.7	8.4	132.2	9.6										
	12.0	2.5	5.7	39.7	29.6	4.5	55.1	8.9	129.2	8.7										

Operation Not Recommended

- Interpolation is permissible; extrapolation is not.
- All entering air conditions are 80°F (26.6°C) DB and 67°F (19.4°C) WB in cooling, and 70°F (21°C) DB in heating.
- AHRI/ISO certified conditions are 80.6°F (27°C) DB and 66.2°F (19°C) WB in cooling and 68°F (20°C) DB in heating.
- Table does not reflect fan or pump power corrections for AHRI/ISO conditions.
- All performance is based upon the lower voltage of dual voltage rated units.
- Performance stated is at the rated power supply; performance may vary as the power supply varies from the rated.
- Operation below 40°F (10.0°C) EWT is based upon 20% methanol antifreeze solution.
- Operation below 60°F (15.5°C) EWT requires optional insulated water/refrigerant circuit.
- See performance correction tables for operating conditions other than those listed above.
- See Performance Data Selection Notes for operation in the shaded areas.
- Regular Cooling operation with an EWT of less than 50°F (10.0°C) is not recommended unless variable water flow is available.
- Regular Heating operation with an EWT of more than 90°F (32°C) is not recommended unless variable water flow is available.
- For quiet operation and long term reliability, it is recommended that systems be designed to avoid continuous operation in the outlined areas.
- Performance capacities shown in thousands of Btuh
- Hot Water Generator Capacity is based on 90°F entering water and 0.5 GPM/Ton.

Heat Controller works continually to improve its products. As a result, the design and specifications of each product at the time of order may be changed without notice and may not be as described herein. Please contact Heat Controller's Customer Service Department at 517-787-2100 for specific information on the current design and specifications. Statements and other information contained herein are not express warranties and do not form the basis of any bargain between the parties, but are merely Heat Controller's opinion or commendation of its products. The latest version of this document is available at www.heatcontroller.com. Engineered and assembled in the USA. © Heat Controller, Inc. All Rights Reserved 2024

Performance Data ME048 EC Blower Motor Modulating Flow (Part Load)

Models:
ME
024-072

1500 CFM Rated Airflow

EWT °F	WPD			COOLING - EAT 80/67 °F							WPD			HEATING - EAT 70°F						
	FLOW GPM	PSI	FT	TC	SC	kW	HR	EER	LWT	HWG Cap	FLOW GPM	PSI	FT	HC	kW	HE	COP	LWT	HWG Cap	
20	6.9	Operation Not Recommended																		
	9.2											9.2	2.1	4.9	23.1	2.2	15.7	3.1	16.6	2.4
30	4.6	0.3	0.6	43.2	30.4	1.2	47.4	35.5	60.0	1.3	4.6	0.7	1.6	25.4	2.2	18.1	3.5	22.1	2.6	
	6.9	0.3	0.6	43.2	30.4	1.2	47.4	35.5	60.0	1.3	6.9	1.3	2.9	26.4	2.2	19.1	3.6	24.5	2.7	
	9.2	0.3	0.6	43.2	30.4	1.2	47.4	35.5	60.0	1.3	9.2	2.0	4.6	27.0	2.2	19.6	3.7	25.7	2.8	
40	4.6	0.6	1.4	41.6	29.0	1.3	45.9	32.8	60.0	1.3	4.6	0.6	1.5	29.2	2.2	21.9	4.0	30.5	2.9	
	6.9	0.6	1.4	41.6	29.0	1.3	45.9	32.8	60.0	1.3	6.9	1.2	2.7	30.6	2.2	23.2	4.1	33.3	3.0	
	9.2	0.6	1.4	41.6	29.0	1.3	45.9	32.8	60.0	1.3	9.2	1.9	4.3	31.3	2.2	23.9	4.2	34.8	3.0	
50	4.6	0.6	1.4	41.5	29.8	1.5	46.4	28.5	70.2	1.5	4.6	0.6	1.4	33.3	2.2	25.9	4.5	38.8	3.1	
	6.9	1.1	2.6	41.6	29.3	1.3	46.2	31.4	63.4	1.5	6.9	1.1	2.6	34.9	2.2	27.5	4.7	42.0	3.2	
	9.2	1.8	4.1	41.5	28.9	1.3	45.8	32.8	60.0	1.4	9.2	1.8	4.1	35.9	2.2	28.4	4.8	43.8	3.3	
60	4.6	0.6	1.4	40.4	29.8	1.7	46.1	24.0	80.0	2.0	4.6	0.6	1.4	37.5	2.2	30.0	5.0	46.9	3.4	
	6.9	1.1	2.5	41.2	29.9	1.5	46.4	27.0	73.5	1.9	6.9	1.1	2.5	39.5	2.2	32.0	5.3	50.7	3.5	
	9.2	1.7	3.9	41.5	29.8	1.5	46.4	28.5	70.1	1.8	9.2	1.7	3.9	40.6	2.2	33.0	5.4	52.8	3.7	
70	4.6	0.6	1.3	38.5	29.0	1.9	45.1	20.0	89.6	2.5	4.6	0.6	1.3	41.8	2.2	34.2	5.5	55.1	3.8	
	6.9	1.1	2.4	39.8	29.6	1.8	45.8	22.6	83.3	2.5	6.9	1.1	2.4	44.0	2.2	36.5	5.8	59.4	3.9	
	9.2	1.7	3.9	40.4	29.8	1.7	46.1	24.0	80.0	2.4	9.2	1.7	3.9	45.3	2.2	37.7	6.0	61.8	4.0	
80	4.6	0.6	1.3	36.1	27.8	2.2	43.6	16.4	99.0	3.3	4.6	0.6	1.3	46.0	2.2	38.4	6.1	63.3	4.2	
	6.9	1.0	2.4	37.7	28.6	2.0	44.6	18.6	92.9	3.2	6.9	1.0	2.4	48.5	2.2	40.9	6.4	68.2	4.3	
	9.2	1.7	3.8	38.5	29.0	1.9	45.1	19.9	89.8	3.1	9.2	1.7	3.8	49.9	2.2	42.2	6.5	70.8	4.4	
85	4.6	0.6	1.3	34.8	27.2	2.3	42.8	14.8	103.6	4.0	4.6	0.6	1.3	48.1	2.2	40.5	6.3	67.4	4.3	
	6.9	1.0	2.4	36.5	28.0	2.2	43.8	16.8	97.7	3.8	6.9	1.0	2.4	50.7	2.2	43.0	6.6	72.5	4.4	
	9.2	1.6	3.8	37.3	28.4	2.1	44.3	18.0	94.6	3.5	9.2	1.6	3.8	52.1	2.3	44.4	6.8	75.3	4.6	
90	4.6	0.6	1.3	33.3	26.4	2.5	41.9	13.3	108.2	4.2	4.6	0.6	1.3	50.2	2.2	42.5	6.6	71.5	4.6	
	6.9	1.0	2.4	35.1	27.3	2.3	43.0	15.2	102.5	4.1	6.9	1.0	2.4	52.8	2.3	45.1	6.9	76.9	4.7	
	9.2	1.6	3.8	36.0	27.8	2.2	43.5	16.2	99.5	4.0	9.2	1.6	3.8	54.2	2.3	46.5	7.0	79.9	4.8	
100	4.6	0.6	1.4	30.4	25.0	2.8	40.0	10.8	117.4	5.3	2.8	0.1	0.2	49.5	2.2	41.8	6.5	70.0	4.6	
	6.9	1.0	2.4	32.2	25.8	2.6	41.1	12.2	111.9	5.2	2.8	0.1	0.2	49.5	2.2	41.8	6.5	70.0	4.6	
	9.2	1.6	3.7	33.1	26.3	2.5	41.7	13.1	109.1	5.0	2.8	0.1	0.2	49.5	2.2	41.8	6.5	70.0	4.6	
110	4.6	0.6	1.3	27.3	23.5	3.2	38.1	8.6	126.6	6.6	2.1	0.1	0.2	49.5	2.2	41.8	6.5	70.0	4.6	
	6.9	1.0	2.4	29.0	24.3	3.0	39.2	9.8	121.3	6.4	2.1	0.1	0.2	49.5	2.2	41.8	6.5	70.0	4.6	
	9.2	1.6	3.7	29.9	24.8	2.9	39.7	10.4	118.6	6.2	2.1	0.1	0.2	49.5	2.2	41.8	6.5	70.0	4.6	
120	4.6	0.6	1.3	24.3	22.2	3.5	36.3	6.9	135.8	8.0	1.7	0.1	0.2	49.5	2.2	41.8	6.5	70.0	4.6	
	6.9	1.0	2.3	25.9	22.9	3.3	37.3	7.8	130.8	7.8	1.7	0.1	0.2	49.5	2.2	41.8	6.5	70.0	4.6	
	9.2	1.6	3.6	26.7	23.3	3.2	37.8	8.3	128.2	7.5	1.7	0.1	0.2	49.5	2.2	41.8	6.5	70.0	4.6	

- Interpolation is permissible; extrapolation is not.
- All entering air conditions are 80°F (26.6°C) DB and 67°F (19.4°C) WB in cooling, and 70°F (21°C) DB in heating.
- AHRI/ISO certified conditions are 80.6°F (27°C) DB and 66.2°F (19°C) WB in cooling and 68°F (20°C) DB in heating.
- Table does not reflect fan or pump power corrections for AHRI/ISO conditions.
- All performance is based upon the lower voltage of dual voltage rated units.
- Performance stated is at the rated power supply; performance may vary as the power supply varies from the rated.
- Operation below 40°F (10.0°C) EWT is based upon 20% methanol antifreeze solution.
- Operation below 60°F (15.5°C) EWT requires optional insulated water/refrigerant circuit.
- See performance correction tables for operating conditions other than those listed above.
- See Performance Data Selection Notes for operation in the shaded areas.
- Regular Cooling operation with an EWT of less than 50°F (10.0°C) is not recommended unless variable water flow is available.
- Regular Heating operation with an EWT of more than 90°F (32°C) is not recommended unless variable water flow is available.
- For quiet operation and long term reliability, it is recommended that systems be designed to avoid continuous operation in the outlined areas.
- Performance capacities shown in thousands of Btuh
- Hot Water Generator Capacity is based on 90°F entering water and 0.5 GPM/Ton.

Heat Controller works continually to improve its products. As a result, the design and specifications of each product at the time of order may be changed without notice and may not be as described herein. Please contact Heat Controller's Customer Service Department at 517-787-2100 for specific information on the current design and specifications. Statements and other information contained herein are not express warranties and do not form the basis of any bargain between the parties, but are merely Heat Controller's opinion or commendation of its products. The latest version of this document is available at www.heatcontroller.com. Engineered and assembled in the USA. © Heat Controller, Inc. All Rights Reserved 2024

ME048 EC Blower Motor Modulating Flow (Full Load)

Models:
ME
024-072

1600 CFM Rated Airflow

EWT °F	WPD			COOLING - EAT 80/67 °F							WPD			HEATING - EAT 70°F					
	FLOW GPM	PSI	FT	TC	SC	kW	HR	EER	LWT	HWG Cap	FLOW GPM	PSI	FT	HC	kW	HE	COP	LWT	HWG Cap
20	9.0	Operation Not Recommended																	
	12.0	12.0	3.4	7.8	34.0	3.0	23.9	3.4	16.0	3.2									
30	4.3	0.4	0.9	57.7	37.5	2.2	65.2	26.1	60.0	1.2	6.0	1.0	2.4	36.5	3.0	26.3	3.6	21.2	3.6
	4.3	0.4	0.9	57.7	37.5	2.2	65.2	26.1	60.0	1.2	9.0	1.9	4.5	37.9	3.0	27.6	3.7	23.9	3.9
	4.3	0.4	0.9	57.7	37.5	2.2	65.2	26.1	60.0	1.2	12.0	3.1	7.2	38.7	3.0	28.4	3.8	25.3	4.3
40	6.3	1.0	2.3	55.5	36.2	2.2	63.1	25.0	60.0	1.2	6.0	0.9	2.2	41.3	3.1	30.9	4.0	29.7	4.0
	6.3	1.0	2.3	55.5	36.2	2.2	63.1	25.0	60.0	1.2	9.0	1.8	4.2	43.2	3.1	32.6	4.1	32.7	4.3
	6.3	1.0	2.3	55.5	36.2	2.2	63.1	25.0	60.0	1.2	12.0	2.9	6.7	44.2	3.1	33.6	4.2	34.4	4.5
50	6.0	0.9	2.1	55.7	37.2	2.5	64.2	22.6	71.4	2.3	6.0	0.9	2.1	46.6	3.2	35.9	4.3	38.0	4.4
	9.0	1.7	3.9	55.9	36.7	2.3	63.7	24.2	64.2	2.1	9.0	1.7	3.9	49.0	3.2	38.1	4.5	41.5	4.8
	12.0	2.8	6.4	55.6	36.3	2.2	63.3	24.9	60.5	1.9	12.0	2.8	6.4	50.3	3.2	39.3	4.6	43.5	5.0
60	6.0	0.9	2.0	54.5	37.1	2.7	63.7	20.1	81.2	3.1	6.0	0.9	2.0	52.3	3.3	41.1	4.7	46.3	4.8
	9.0	1.6	3.8	55.5	37.3	2.5	64.1	21.9	74.3	2.8	9.0	1.6	3.8	55.1	3.3	43.7	4.8	50.3	5.3
	12.0	2.7	6.2	55.8	37.2	2.4	64.1	22.8	70.7	2.6	12.0	2.7	6.2	56.6	3.4	45.1	4.9	52.5	5.7
70	6.0	0.9	2.0	52.3	36.2	3.0	62.4	17.6	90.8	4.0	6.0	0.9	2.0	58.1	3.4	46.4	5.0	54.5	5.3
	9.0	1.6	3.7	53.9	36.9	2.8	63.4	19.4	84.1	3.6	9.0	1.6	3.7	61.2	3.5	49.3	5.1	59.0	5.9
	12.0	2.6	6.1	54.6	37.1	2.7	63.8	20.3	80.6	3.3	12.0	2.6	6.1	62.9	3.5	50.9	5.2	61.5	6.4
80	6.0	0.8	2.0	49.4	34.8	3.3	60.6	15.1	100.2	5.0	6.0	0.8	2.0	63.8	3.5	51.6	5.3	62.8	5.9
	9.0	1.6	3.7	51.4	35.8	3.1	61.9	16.8	93.8	4.6	9.0	1.6	3.7	67.1	3.6	54.7	5.4	67.8	6.5
	12.0	2.6	6.0	52.4	36.3	3.0	62.5	17.7	90.4	4.2	12.0	2.6	6.0	68.8	3.7	56.3	5.5	70.6	7.1
85	6.0	0.8	2.0	47.9	34.0	3.4	59.6	13.9	104.9	5.6	6.0	0.8	2.0	66.5	3.6	54.2	5.4	66.9	6.2
	9.0	1.6	3.7	50.0	35.1	3.2	61.0	15.5	98.5	4.9	9.0	1.6	3.7	69.8	3.7	57.2	5.5	72.3	6.8
	12.0	2.6	5.9	51.0	35.6	3.1	61.6	16.4	95.3	4.7	12.0	2.6	5.9	71.6	3.7	58.8	5.6	75.2	7.4
90	6.0	0.8	2.0	46.3	33.2	3.6	58.6	12.8	109.5	6.2	5.6	0.1	0.2	68.5	3.7	56.0	5.5	70.0	7.4
	9.0	1.6	3.7	48.4	34.3	3.4	60.0	14.3	103.3	5.7	5.6	0.1	0.2	68.5	3.7	56.0	5.5	70.0	7.4
	12.0	2.6	5.9	49.5	34.9	3.3	60.6	15.1	100.1	5.1	5.6	0.1	0.2	68.5	3.7	56.0	5.5	70.0	7.4
100	6.0	0.8	2.0	43.1	31.4	4.0	56.7	10.8	118.9	7.5	3.7	0.1	0.2	68.5	3.7	56.0	5.5	70.0	7.4
	9.0	1.6	3.6	45.2	32.5	3.7	57.9	12.0	112.9	6.8	3.7	0.1	0.2	68.5	3.7	56.0	5.5	70.0	7.4
	12.0	2.5	5.9	46.2	33.1	3.6	58.6	12.8	109.8	6.2	3.7	0.1	0.2	68.5	3.7	56.0	5.5	70.0	7.4
110	6.0	0.8	1.9	40.0	29.7	4.4	55.2	9.0	128.4	8.9	2.8	0.1	0.2	68.5	3.7	56.0	5.5	70.0	7.4
	9.0	1.6	3.6	41.9	30.7	4.2	56.1	10.1	122.5	8.2	2.8	0.1	0.2	68.5	3.7	56.0	5.5	70.0	7.4
	12.0	2.5	5.8	42.9	31.3	4.0	56.6	10.7	119.4	7.4	2.8	0.1	0.2	68.5	3.7	56.0	5.5	70.0	7.4
120	6.0	0.8	1.9	37.3	28.4	5.0	54.2	7.5	138.1	10.5	2.2	0.1	0.2	68.5	3.7	56.0	5.5	70.0	7.4
	9.0	1.5	3.5	38.9	29.1	4.6	54.7	8.4	132.2	9.6	2.2	0.1	0.2	68.5	3.7	56.0	5.5	70.0	7.4
	12.0	2.5	5.7	39.7	29.6	4.5	55.1	8.9	129.2	8.7	2.2	0.1	0.2	68.5	3.7	56.0	5.5	70.0	7.4

- Interpolation is permissible; extrapolation is not.
- All entering air conditions are 80°F (26.6°C) DB and 67°F (19.4°C) WB in cooling, and 70°F (21°C) DB in heating.
- AHRI/ISO certified conditions are 80.6°F (27°C) DB and 66.2°F (19°C) WB in cooling and 68°F (20°C) DB in heating.
- Table does not reflect fan or pump power corrections for AHRI/ISO conditions.
- All performance is based upon the lower voltage of dual voltage rated units.
- Performance stated is at the rated power supply; performance may vary as the power supply varies from the rated.
- Operation below 40°F (10.0°C) EWT is based upon 20% methanol antifreeze solution.
- Operation below 60°F (15.5°C) EWT requires optional insulated water/refrigerant circuit.
- See performance correction tables for operating conditions other than those listed above.
- See Performance Data Selection Notes for operation in the shaded areas.
- Regular Cooling operation with an EWT of less than 50°F (10.0°C) is not recommended unless variable water flow is available.
- Regular Heating operation with an EWT of more than 90°F (32°C) is not recommended unless variable water flow is available.
- For quiet operation and long term reliability, it is recommended that systems be designed to avoid continuous operation in the outlined areas.
- Performance capacities shown in thousands of Btuh
- Hot Water Generator Capacity is based on 90°F entering water and 0.5 GPM/Ton.

Heat Controller works continually to improve its products. As a result, the design and specifications of each product at the time of order may be changed without notice and may not be as described herein. Please contact Heat Controller's Customer Service Department at 517-787-2100 for specific information on the current design and specifications. Statements and other information contained herein are not express warranties and do not form the basis of any bargain between the parties, but are merely Heat Controller's opinion or commendation of its products. The latest version of this document is available at www.heatcontroller.com. Engineered and assembled in the USA. © Heat Controller, Inc. All Rights Reserved 2024

Performance Data ME060 EC Blower Motor (Part Load)

Models:
ME
024-072

1,700 CFM Rated Airflow

EWT °F	WPD			Cooling - EAT 80/67°F							WPD			Heating - EAT 70°F						
	FLOW GPM	PSI	FT	TC	SC	kW	HR	EER	LWT	HWG Cap	FLOW GPM	PSI	FT	HC	kW	HE	COP	LWT	HWG Cap	
20	8.0	Operation Not Recommended										10.5	3.6	8.3	24.3	2.5	15.8	2.9	17.0	3.0
	10.5																			
30	5.3	1.2	2.8	48.9	35.9	1.4	53.9	33.8	50.5	1.4	5.3	1.2	2.8	26.7	2.5	18.2	3.1	23.1	3.0	
	8.0	2.2	5.1	46.3	33.4	1.3	50.9	34.3	42.8	1.3	8.0	2.2	5.1	27.6	2.5	19.1	3.2	25.2	3.1	
	10.5	3.1	7.2	44.6	32.1	1.3	49.0	34.0	39.3	1.3	10.5	3.1	7.2	28.1	2.5	19.5	3.3	26.3	3.1	
40	5.3	0.9	2.2	50.4	38.1	1.6	55.9	31.0	61.3	1.5	5.3	0.9	2.2	30.6	2.5	22.0	3.5	31.6	3.1	
	8.0	1.9	4.3	49.6	36.7	1.5	54.7	33.2	53.8	1.4	8.0	1.9	4.3	31.9	2.5	23.2	3.7	34.2	3.2	
	10.5	2.7	6.3	48.8	35.8	1.4	53.8	33.9	50.2	1.4	10.5	2.7	6.3	32.5	2.5	23.9	3.8	35.5	3.3	
50	5.3	0.8	1.8	49.9	39.0	1.8	56.2	27.1	71.4	1.5	5.3	0.8	1.8	34.9	2.6	26.2	4.0	40.0	3.3	
	8.0	1.6	3.7	50.4	38.5	1.7	56.2	30.0	64.1	1.5	8.0	1.6	3.7	36.5	2.6	27.8	4.2	43.0	3.4	
	10.5	2.4	5.6	50.4	38.0	1.6	55.9	31.2	60.6	1.5	10.5	2.4	5.6	37.4	2.6	28.6	4.3	44.5	3.5	
60	5.3	0.6	1.5	48.1	39.1	2.1	55.3	23.1	81.1	2.3	5.3	0.6	1.5	39.5	2.6	30.7	4.5	48.3	3.5	
	8.0	1.4	3.3	49.5	39.1	1.9	56.0	26.0	74.1	2.1	8.0	1.4	3.3	41.5	2.6	32.7	4.7	51.8	3.7	
	10.5	2.2	5.1	50.0	39.0	1.8	56.2	27.4	70.7	2.0	10.5	2.2	5.1	42.5	2.6	33.7	4.8	53.6	3.8	
70	5.3	0.6	1.3	45.7	38.5	2.4	53.7	19.4	90.5	3.0	5.3	0.6	1.3	44.2	2.6	35.4	5.0	56.5	3.9	
	8.0	1.3	3.1	47.5	39.0	2.2	54.9	22.0	83.8	2.9	8.0	1.3	3.1	46.6	2.6	37.7	5.3	60.5	4.0	
	10.5	2.0	4.7	48.3	39.1	2.1	55.3	23.3	80.5	2.8	10.5	2.0	4.7	47.8	2.6	39.0	5.4	62.6	4.1	
80	5.3	0.6	1.3	42.9	37.5	2.7	52.0	16.1	99.8	3.9	5.3	0.6	1.3	49.1	2.6	40.2	5.5	64.7	4.2	
	8.0	1.2	2.9	44.8	38.2	2.5	53.2	18.3	93.4	3.7	8.0	1.2	2.9	51.8	2.6	42.9	5.8	69.2	4.4	
	10.5	1.9	4.4	45.8	38.5	2.4	53.8	19.4	90.2	3.6	10.5	1.9	4.4	53.3	2.6	44.4	6.0	71.6	4.5	
85	5.3	0.5	1.3	41.5	36.9	2.8	51.2	14.6	104.5	4.6	5.3	0.5	1.3	51.6	2.6	42.7	5.8	68.7	4.4	
	8.0	1.2	2.8	43.4	37.7	2.6	52.3	16.6	98.2	4.3	8.0	1.2	2.8	54.5	2.6	45.6	6.1	73.5	4.5	
	10.5	1.8	4.3	44.3	38.1	2.5	52.9	17.7	95.1	4.1	10.5	1.8	4.3	56.0	2.6	47.1	6.3	76.0	4.7	
90	5.3	0.5	1.3	40.1	36.3	3.0	50.4	13.3	109.2	5.0	5.3	0.5	1.3	54.0	2.6	45.1	6.1	72.8	4.7	
	8.0	1.2	2.8	41.9	37.1	2.8	51.4	15.1	102.9	4.9	8.0	1.2	2.8	57.1	2.6	48.2	6.4	77.9	4.8	
	10.5	1.8	4.2	42.9	37.5	2.7	52.0	16.0	99.9	4.7	10.5	1.8	4.2	58.7	2.6	49.7	6.6	80.5	5.0	
100	5.3	0.5	1.3	37.7	35.3	3.4	49.3	11.1	118.8	6.3	Operation Not Recommended									
	8.0	1.2	2.7	39.2	35.9	3.1	49.9	12.5	112.6	6.1										
	10.5	1.8	4.1	40.0	36.3	3.0	50.3	13.2	109.6	6.0										
110	5.3	0.5	1.2	36.2	34.7	3.8	49.3	9.4	128.8	7.9										
	8.0	1.2	2.7	37.0	35.0	3.6	49.2	10.4	122.4	7.6										
	10.5	1.7	4.0	37.6	35.2	3.4	49.3	11.0	119.4	7.4										
120	5.3	0.5	1.2	36.1	35.4	4.3	50.9	8.3	139.4	9.6										
	8.0	1.1	2.6	35.9	34.8	4.0	49.6	9.0	132.5	9.4										
	10.5	1.7	4.0	36.1	34.7	3.9	49.3	9.3	129.4	9.1										

- Interpolation is permissible; extrapolation is not.
- All entering air conditions are 80°F (26.6°C) DB and 67°F (19.4°C) WB in cooling, and 70°F (21°C) DB in heating.
- AHRI/ISO certified conditions are 80.6°F (27°C) DB and 66.2°F (19°C) WB in cooling and 68°F (20°C) DB in heating.
- Table does not reflect fan or pump power corrections for AHRI/ISO conditions.
- All performance is based upon the lower voltage of dual voltage rated units.
- Performance stated is at the rated power supply; performance may vary as the power supply varies from the rated.
- Operation below 40°F (10.0°C) EWT is based upon 20% methanol antifreeze solution.
- Operation below 60°F (15.5°C) EWT requires optional insulated water/refrigerant circuit.
- See performance correction tables for operating conditions other than those listed above.
- See Performance Data Selection Notes for operation in the shaded areas.
- Regular Cooling operation with an EWT of less than 50°F (10.0°C) is not recommended unless variable water flow is available.
- Regular Heating operation with an EWT of more than 90°F (32°C) is not recommended unless variable water flow is available.
- For quiet operation and long term reliability, it is recommended that systems be designed to avoid continuous operation in the outlined areas.
- Performance capacities shown in thousands of Btuh
- Hot Water Generator Capacity is based on 90°F entering water and 0.5 GPM/Ton.

Heat Controller works continually to improve its products. As a result, the design and specifications of each product at the time of order may be changed without notice and may not be as described herein. Please contact Heat Controller's Customer Service Department at 517-787-2100 for specific information on the current design and specifications. Statements and other information contained herein are not express warranties and do not form the basis of any bargain between the parties, but are merely Heat Controller's opinion or commendation of its products. The latest version of this document is available at www.heatcontroller.com. Engineered and assembled in the USA. © Heat Controller, Inc. All Rights Reserved 2024

Performance Data ME060 EC Blower Motor (Full Load)

Models:
ME
024-072

1,900 CFM Rated Airflow

EWT °F	WPD			Cooling - EAT 80/67°F							WPD			Heating - EAT 70°F						
	FLOW GPM	PSI	FT	TC	SC	kW	HR	EER	LWT	HWG Cap	FLOW GPM	PSI	FT	HC	kW	HE	COP	LWT	HWG Cap	
20	11.3	Operation Not Recommended										15.0	6.5	15.0	38.9	3.4	27.1	3.3	16.4	3.9
	15.0																			
30	7.5	2.0	4.6	62.5	43.9	2.4	70.7	26.0	48.8	2.4	7.5	2.0	4.6	42.4	3.5	30.4	3.5	21.9	4.2	
	11.3	3.8	8.8	56.8	39.9	2.2	64.2	26.0	41.4	2.4	11.3	3.8	8.8	44.0	3.5	31.9	3.6	24.3	4.3	
	15.0	5.6	13.0	53.5	37.8	2.1	60.6	25.7	38.1	2.3	15.0	5.6	13.0	44.8	3.5	32.7	3.7	25.6	4.3	
40	7.5	1.6	3.7	67.6	47.7	2.7	76.9	24.8	60.5	2.5	7.5	1.6	3.7	48.1	3.6	35.8	3.9	30.5	4.5	
	11.3	3.3	7.6	64.8	45.5	2.5	73.4	25.7	53.1	2.5	11.3	3.3	7.6	50.1	3.6	37.7	4.0	33.3	4.5	
	15.0	4.9	11.4	62.9	44.1	2.4	71.1	26.0	49.5	2.4	15.0	4.9	11.4	51.2	3.7	38.7	4.1	34.8	4.5	
50	7.5	1.3	3.1	68.9	49.2	3.0	79.3	22.8	71.1	2.6	7.5	1.3	3.1	54.1	3.7	41.5	4.3	38.9	4.9	
	11.3	2.9	6.6	68.4	48.3	2.8	78.0	24.2	63.9	2.6	11.3	2.9	6.6	56.5	3.8	43.7	4.4	42.2	5.0	
	15.0	4.4	10.2	67.6	47.6	2.7	76.8	24.8	60.2	2.7	15.0	4.4	10.2	57.8	3.8	44.9	4.5	44.0	5.1	
60	7.5	1.2	2.7	67.9	49.3	3.3	79.2	20.5	81.1	3.8	7.5	1.2	2.7	60.3	3.8	47.3	4.6	47.4	5.4	
	11.3	2.6	6.0	68.8	49.4	3.1	79.4	22.2	74.1	3.6	11.3	2.6	6.0	63.1	3.9	49.9	4.8	51.1	5.6	
	15.0	4.0	9.3	68.9	49.2	3.0	79.2	22.9	70.6	3.4	15.0	4.0	9.3	64.6	3.9	51.3	4.8	53.2	5.8	
70	7.5	1.1	2.5	65.4	48.5	3.6	77.7	18.0	90.7	4.6	7.5	1.1	2.5	66.6	4.0	53.2	4.9	55.8	5.9	
	11.3	2.4	5.6	67.3	49.1	3.4	78.9	19.8	84.0	4.5	11.3	2.4	5.6	69.8	4.0	56.1	5.1	60.0	6.4	
	15.0	3.7	8.6	68.0	49.3	3.3	79.3	20.6	80.6	4.2	15.0	3.7	8.6	71.5	4.1	57.7	5.2	62.3	6.8	
80	7.5	1.0	2.4	61.9	47.0	4.0	75.4	15.6	100.1	5.6	7.5	1.0	2.4	73.0	4.1	59.0	5.2	64.3	6.4	
	11.3	2.3	5.3	64.3	48.1	3.7	77.0	17.3	93.7	5.5	11.3	2.3	5.3	76.4	4.2	62.2	5.4	68.9	7.1	
	15.0	3.5	8.2	65.5	48.5	3.6	77.8	18.1	90.4	5.0	15.0	3.5	8.2	78.3	4.2	63.9	5.4	71.5	7.6	
85	7.5	1.0	2.4	60.0	46.1	4.2	74.2	14.4	104.8	6.3	7.5	1.0	2.4	76.1	4.2	61.9	5.4	68.5	6.8	
	11.3	2.3	5.2	62.5	47.3	3.9	75.9	16.0	98.5	6.0	11.3	2.3	5.2	79.7	4.3	65.2	5.5	73.4	7.4	
	15.0	3.5	8.0	63.8	47.8	3.8	76.7	16.9	95.2	5.5	15.0	3.5	8.0	81.6	4.3	66.9	5.6	76.1	8.0	
90	7.5	1.0	2.4	58.0	45.2	4.4	72.9	13.3	109.4	7.4	7.5	1.0	2.4	79.2	4.2	64.7	5.5	72.7	7.0	
	11.3	2.2	5.2	60.6	46.4	4.1	74.6	14.8	103.3	6.6	11.3	2.2	5.2	82.9	4.3	68.1	5.6	77.9	7.7	
	15.0	3.4	7.9	61.9	47.0	4.0	75.4	15.6	100.1	6.1	15.0	3.4	7.9	84.9	4.4	69.9	5.7	80.7	8.4	
100	7.5	1.0	2.4	54.1	43.4	4.8	70.6	11.2	118.8	8.9	Operation Not Recommended									
	11.3	2.2	5.1	56.6	44.5	4.5	72.0	12.5	112.8	8.2										
	15.0	3.3	7.7	57.9	45.2	4.4	72.8	13.2	109.7	7.4										
110	7.5	1.0	2.3	50.6	41.8	5.4	69.0	9.4	128.4	10.7										
	11.3	2.1	4.9	52.7	42.7	5.0	69.8	10.5	122.4	9.8										
	15.0	3.3	7.6	53.9	43.3	4.9	70.4	11.1	119.4	8.9										
120	7.5	0.9	2.1	48.1	41.0	6.1	68.8	7.9	138.3	12.4										
	11.3	2.1	4.8	49.5	41.4	5.6	68.7	8.8	132.2	11.2										
	15.0	3.2	7.5	50.4	41.7	5.4	68.9	9.3	129.2	10.6										

- Interpolation is permissible; extrapolation is not.
- All entering air conditions are 80°F (26.6°C) DB and 67°F (19.4°C) WB in cooling, and 70°F (21°C) DB in heating.
- AHRI/ISO certified conditions are 80.6°F (27°C) DB and 66.2°F (19°C) WB in cooling and 68°F (20°C) DB in heating.
- Table does not reflect fan or pump power corrections for AHRI/ISO conditions.
- All performance is based upon the lower voltage of dual voltage rated units.
- Performance stated is at the rated power supply; performance may vary as the power supply varies from the rated.
- Operation below 40°F (10.0°C) EWT is based upon 20% methanol antifreeze solution.
- Operation below 60°F (15.5°C) EWT requires optional insulated water/refrigerant circuit.
- See performance correction tables for operating conditions other than those listed above.
- See Performance Data Selection Notes for operation in the shaded areas.
- Regular Cooling operation with an EWT of less than 50°F (10.0°C) is not recommended unless variable water flow is available.
- Regular Heating operation with an EWT of more than 90°F (32°C) is not recommended unless variable water flow is available.
- For quiet operation and long term reliability, it is recommended that systems be designed to avoid continuous operation in the outlined areas.
- Performance capacities shown in thousands of Btuh
- Hot Water Generator Capacity is based on 90°F entering water and 0.5 GPM/Ton.

Heat Controller works continually to improve its products. As a result, the design and specifications of each product at the time of order may be changed without notice and may not be as described herein. Please contact Heat Controller's Customer Service Department at 517-787-2100 for specific information on the current design and specifications. Statements and other information contained herein are not express warranties and do not form the basis of any bargain between the parties, but are merely Heat Controller's opinion or commendation of its products. The latest version of this document is available at www.heatcontroller.com. Engineered and assembled in the USA. © Heat Controller, Inc. All Rights Reserved 2024

ME060 EC Blower Motor Modulating Flow (Part Load)

Models:
ME
024-072

1700 CFM Rated Airflow

EWT °F	WPD			COOLING - EAT 80/67 °F							WPD			HEATING - EAT 70°F					
	FLOW GPM	PSI	FT	TC	SC	kW	HR	EER	LWT	HWG Cap	FLOW GPM	PSI	FT	HC	kW	HE	COP	LWT	HWG Cap
20	8.0	Operation Not Recommended																	
	10.5	10.5	3.6	8.3	24.3	2.5	15.8	2.9	17.0	3.0									
30	5.3	0.7	1.5	48.9	35.9	1.4	53.9	33.8	50.5	1.3	5.3	1.2	2.8	26.7	2.5	18.2	3.1	23.1	3.0
	8.0	0.7	1.5	46.3	33.4	1.3	50.9	34.3	42.8	1.3	8.0	2.2	5.1	27.6	2.5	19.1	3.2	25.2	3.1
	10.5	0.7	1.5	44.6	32.1	1.3	49.0	34.0	39.3	1.3	10.5	3.1	7.2	28.1	2.5	19.5	3.3	26.3	3.1
40	5.3	1.0	2.4	50.4	38.1	1.6	55.9	31.0	61.3	1.3	5.3	0.9	2.2	30.6	2.5	22.0	3.5	31.6	3.1
	8.0	1.0	2.4	49.6	36.7	1.5	54.7	33.2	53.8	1.3	8.0	1.9	4.3	31.9	2.5	23.2	3.7	34.2	3.2
	10.5	1.0	2.4	48.8	35.8	1.4	53.8	33.9	50.2	1.3	10.5	2.7	6.3	32.5	2.5	23.9	3.8	35.5	3.3
50	5.3	0.8	1.8	49.9	39.0	1.8	56.2	27.1	71.4	1.8	5.3	0.8	1.8	34.9	2.6	26.2	4.0	40.0	3.3
	8.0	1.6	3.7	50.4	38.5	1.7	56.2	30.0	64.1	1.8	8.0	1.6	3.7	36.5	2.6	27.8	4.2	43.0	3.4
	10.5	2.4	5.6	50.4	38.0	1.6	55.9	31.2	60.6	1.7	10.5	2.4	5.6	37.4	2.6	28.6	4.3	44.5	3.5
60	5.3	0.6	1.5	48.1	39.1	2.1	55.3	23.1	81.1	2.3	5.3	0.6	1.5	39.5	2.6	30.7	4.5	48.3	3.5
	8.0	1.4	3.3	49.5	39.1	1.9	56.0	26.0	74.1	2.1	8.0	1.4	3.3	41.5	2.6	32.7	4.7	51.8	3.7
	10.5	2.2	5.1	50.0	39.0	1.8	56.2	27.4	70.7	2.0	10.5	2.2	5.1	42.5	2.6	33.7	4.8	53.6	3.8
70	5.3	0.6	1.3	45.7	38.5	2.4	53.7	19.4	90.5	3.0	5.3	0.6	1.3	44.2	2.6	35.4	5.0	56.5	3.9
	8.0	1.3	3.1	47.5	39.0	2.2	54.9	22.0	83.8	2.9	8.0	1.3	3.1	46.6	2.6	37.7	5.3	60.5	4.0
	10.5	2.0	4.7	48.3	39.1	2.1	55.3	23.3	80.5	2.8	10.5	2.0	4.7	47.8	2.6	39.0	5.4	62.6	4.1
80	5.3	0.6	1.3	42.9	37.5	2.7	52.0	16.1	99.8	3.9	5.3	0.6	1.3	49.1	2.6	40.2	5.5	64.7	4.2
	8.0	1.2	2.9	44.8	38.2	2.5	53.2	18.3	93.4	3.7	8.0	1.2	2.9	51.8	2.6	42.9	5.8	69.2	4.4
	10.5	1.9	4.4	45.8	38.5	2.4	53.8	19.4	90.2	3.6	10.5	1.9	4.4	53.3	2.6	44.4	6.0	71.6	4.5
85	5.3	0.5	1.3	41.5	36.9	2.8	51.2	14.6	104.5	4.6	5.3	0.5	1.3	51.6	2.6	42.7	5.8	68.7	4.4
	8.0	1.2	2.8	43.4	37.7	2.6	52.3	16.6	98.2	4.3	8.0	1.2	2.8	54.5	2.6	45.6	6.1	73.5	4.5
	10.5	1.8	4.3	44.3	38.1	2.5	52.9	17.7	95.1	4.1	10.5	1.8	4.3	56.0	2.6	47.1	6.3	76.0	4.7
90	5.3	0.5	1.3	40.1	36.3	3.0	50.4	13.3	109.2	5.0	5.3	0.5	1.3	54.0	2.6	45.1	6.1	72.8	4.7
	8.0	1.2	2.8	41.9	37.1	2.8	51.4	15.1	102.9	4.9	8.0	1.2	2.8	57.1	2.6	48.2	6.4	77.9	4.8
	10.5	1.8	4.2	42.9	37.5	2.7	52.0	16.0	99.9	4.7	10.5	1.8	4.2	58.7	2.6	49.7	6.6	80.5	5.0
100	5.3	0.5	1.3	37.7	35.3	3.4	49.3	11.1	118.8	6.3	2.9	0.1	0.2	52.3	2.6	43.4	5.9	70.0	4.7
	8.0	1.2	2.7	39.2	35.9	3.1	49.9	12.5	112.6	6.1	2.9	0.1	0.2	52.3	2.6	43.4	5.9	70.0	4.7
	10.5	1.8	4.1	40.0	36.3	3.0	50.3	13.2	109.6	6.0	2.9	0.1	0.2	52.3	2.6	43.4	5.9	70.0	4.7
110	5.3	0.5	1.2	36.2	34.7	3.8	49.3	9.4	128.8	7.9	2.2	0.1	0.2	52.3	2.6	43.4	5.9	70.0	4.7
	8.0	1.2	2.7	37.0	35.0	3.6	49.2	10.4	122.4	7.6	2.2	0.1	0.2	52.3	2.6	43.4	5.9	70.0	4.7
	10.5	1.7	4.0	37.6	35.2	3.4	49.3	11.0	119.4	7.4	2.2	0.1	0.2	52.3	2.6	43.4	5.9	70.0	4.7
120	5.3	0.5	1.2	36.1	35.4	4.3	50.9	8.3	139.4	9.6	1.7	0.1	0.2	52.3	2.6	43.4	5.9	70.0	4.7
	8.0	1.1	2.6	35.9	34.8	4.0	49.6	9.0	132.5	9.4	1.7	0.1	0.2	52.3	2.6	43.4	5.9	70.0	4.7
	10.5	1.7	4.0	36.1	34.7	3.9	49.3	9.3	129.4	9.1	1.7	0.1	0.2	52.3	2.6	43.4	5.9	70.0	4.7

- Interpolation is permissible; extrapolation is not.
- All entering air conditions are 80°F (26.6°C) DB and 67°F (19.4°C) WB in cooling, and 70°F (21°C) DB in heating.
- AHRI/ISO certified conditions are 80.6°F (27°C) DB and 66.2°F (19°C) WB in cooling and 68°F (20°C) DB in heating.
- Table does not reflect fan or pump power corrections for AHRI/ISO conditions.
- All performance is based upon the lower voltage of dual voltage rated units.
- Performance stated is at the rated power supply; performance may vary as the power supply varies from the rated.
- Operation below 40°F (10.0°C) EWT is based upon 20% methanol antifreeze solution.
- Operation below 60°F (15.5°C) EWT requires optional insulated water/refrigerant circuit.
- See performance correction tables for operating conditions other than those listed above.
- See Performance Data Selection Notes for operation in the shaded areas.
- Regular Cooling operation with an EWT of less than 50°F (10.0°C) is not recommended unless variable water flow is available.
- Regular Heating operation with an EWT of more than 90°F (32°C) is not recommended unless variable water flow is available.
- For quiet operation and long term reliability, it is recommended that systems be designed to avoid continuous operation in the outlined areas.
- Performance capacities shown in thousands of Btuh
- Hot Water Generator Capacity is based on 90°F entering water and 0.5 GPM/Ton.

Heat Controller works continually to improve its products. As a result, the design and specifications of each product at the time of order may be changed without notice and may not be as described herein. Please contact Heat Controller's Customer Service Department at 517-787-2100 for specific information on the current design and specifications. Statements and other information contained herein are not express warranties and do not form the basis of any bargain between the parties, but are merely Heat Controller's opinion or commendation of its products. The latest version of this document is available at www.heatcontroller.com. Engineered and assembled in the USA. © Heat Controller, Inc. All Rights Reserved 2024

ME060 EC Blower Motor Modulating Flow (Full Load)

Models:
ME
024-072

1900 CFM Rated Airflow

EWT °F	WPD			COOLING - EAT 80/67 °F							WPD			HEATING - EAT 70°F						
	FLOW GPM	PSI	FT	TC	SC	kW	HR	EER	LWT	HWG Cap	FLOW GPM	PSI	FT	HC	kW	HE	COP	LWT	HWG Cap	
20	11.3	Operation Not Recommended										15.0	6.5	15.0	38.9	3.4	27.1	3.3	16.4	3.9
	15.0																			
30	5.4	1.0	2.3	71.7	50.2	2.7	81.1	26.2	60.0	2.4	7.5	2.0	4.6	42.4	3.5	30.4	3.5	21.9	4.2	
	5.4	1.0	2.3	71.7	50.2	2.7	81.1	26.2	60.0	2.4	11.3	3.8	8.8	44.0	3.5	31.9	3.6	24.3	4.3	
	5.4	1.0	2.3	71.7	50.2	2.7	81.1	26.2	60.0	2.4	15.0	5.6	13.0	44.8	3.5	32.7	3.7	25.6	4.3	
40	7.7	1.7	3.9	67.5	47.6	2.7	76.8	24.9	60.0	2.4	7.5	1.6	3.7	48.1	3.6	35.8	3.9	30.5	4.5	
	7.7	1.7	3.9	67.5	47.6	2.7	76.8	24.9	60.0	2.4	11.3	3.3	7.6	50.1	3.6	37.7	4.0	33.3	4.5	
	7.7	1.7	3.9	67.5	47.6	2.7	76.8	24.9	60.0	2.4	15.0	4.9	11.4	51.2	3.7	38.7	4.1	34.8	4.5	
50	7.5	1.3	3.1	68.9	49.2	3.0	79.3	22.8	71.1	3.6	7.5	1.3	3.1	54.1	3.7	41.5	4.3	38.9	4.9	
	11.3	2.9	6.6	68.4	48.3	2.8	78.0	24.2	63.9	3.3	11.3	2.9	6.6	56.5	3.8	43.7	4.4	42.2	5.0	
	15.0	4.4	10.2	67.6	47.6	2.7	76.8	24.8	60.2	3.0	15.0	4.4	10.2	57.8	3.8	44.9	4.5	44.0	5.1	
60	7.5	1.2	2.7	67.9	49.3	3.3	79.2	20.5	81.1	3.8	7.5	1.2	2.7	60.3	3.8	47.3	4.6	47.4	5.4	
	11.3	2.6	6.0	68.8	49.4	3.1	79.4	22.2	74.1	3.6	11.3	2.6	6.0	63.1	3.9	49.9	4.8	51.1	5.6	
	15.0	4.0	9.3	68.9	49.2	3.0	79.2	22.9	70.6	3.4	15.0	4.0	9.3	64.6	3.9	51.3	4.8	53.2	5.8	
70	7.5	1.1	2.5	65.4	48.5	3.6	77.7	18.0	90.7	4.6	7.5	1.1	2.5	66.6	4.0	53.2	4.9	55.8	5.9	
	11.3	2.4	5.6	67.3	49.1	3.4	78.9	19.8	84.0	4.5	11.3	2.4	5.6	69.8	4.0	56.1	5.1	60.0	6.4	
	15.0	3.7	8.6	68.0	49.3	3.3	79.3	20.6	80.6	4.2	15.0	3.7	8.6	71.5	4.1	57.7	5.2	62.3	6.8	
80	7.5	1.0	2.4	61.9	47.0	4.0	75.4	15.6	100.1	5.6	7.5	1.0	2.4	73.0	4.1	59.0	5.2	64.3	6.4	
	11.3	2.3	5.3	64.3	48.1	3.7	77.0	17.3	93.7	5.5	11.3	2.3	5.3	76.4	4.2	62.2	5.4	68.9	7.1	
	15.0	3.5	8.2	65.5	48.5	3.6	77.8	18.1	90.4	5.0	15.0	3.5	8.2	78.3	4.2	63.9	5.4	71.5	7.6	
85	7.5	1.0	2.4	60.0	46.1	4.2	74.2	14.4	104.8	6.3	7.5	1.0	2.4	76.1	4.2	61.9	5.4	68.5	6.8	
	11.3	2.3	5.2	62.5	47.3	3.9	75.9	16.0	98.5	6.0	11.3	2.3	5.2	79.7	4.3	65.2	5.5	73.4	7.4	
	15.0	3.5	8.0	63.8	47.8	3.8	76.7	16.9	95.2	5.5	15.0	3.5	8.0	81.6	4.3	66.9	5.6	76.1	8.0	
90	7.5	1.0	2.4	58.0	45.2	4.4	72.9	13.3	109.4	7.4	6.3	0.1	0.2	77.2	4.2	63.0	5.4	70.0	8.0	
	11.3	2.2	5.2	60.6	46.4	4.1	74.6	14.8	103.3	6.6	6.3	0.1	0.2	77.2	4.2	63.0	5.4	70.0	8.0	
	15.0	3.4	7.9	61.9	47.0	4.0	75.4	15.6	100.1	6.1	6.3	0.1	0.2	77.2	4.2	63.0	5.4	70.0	8.0	
100	7.5	1.0	2.4	54.1	43.4	4.8	70.6	11.2	118.8	8.9	1.8	0.1	0.2	33.1	1.7	27.2	5.6	70.0	8.0	
	11.3	2.2	5.1	56.6	44.5	4.5	72.0	12.5	112.8	8.2	1.8	0.1	0.2	33.1	1.7	27.2	5.6	70.0	8.0	
	15.0	3.3	7.7	57.9	45.2	4.4	72.8	13.2	109.7	7.4	1.8	0.1	0.2	33.1	1.7	27.2	5.6	70.0	8.0	
110	7.5	1.0	2.3	50.6	41.8	5.4	69.0	9.4	128.4	10.7	1.4	0.1	0.2	33.1	1.7	27.2	5.6	70.0	8.0	
	11.3	2.1	4.9	52.7	42.7	5.0	69.8	10.5	122.4	9.8	1.4	0.1	0.2	33.1	1.7	27.2	5.6	70.0	8.0	
	15.0	3.3	7.6	53.9	43.3	4.9	70.4	11.1	119.4	8.9	1.4	0.1	0.2	33.1	1.7	27.2	5.6	70.0	8.0	
120	7.5	0.9	2.1	48.1	41.0	6.1	68.8	7.9	138.3	12.4	1.1	0.1	0.2	33.1	1.7	27.2	5.6	70.0	8.0	
	11.3	2.1	4.8	49.5	41.4	5.6	68.7	8.8	132.2	11.2	1.1	0.1	0.2	33.1	1.7	27.2	5.6	70.0	8.0	
	15.0	3.2	7.5	50.4	41.7	5.4	68.9	9.3	129.2	10.6	1.1	0.1	0.2	33.1	1.7	27.2	5.6	70.0	8.0	

- Interpolation is permissible; extrapolation is not.
- All entering air conditions are 80°F (26.6°C) DB and 67°F (19.4°C) WB in cooling, and 70°F (21°C) DB in heating.
- AHRI/ISO certified conditions are 80.6°F (27°C) DB and 66.2°F (19°C) WB in cooling and 68°F (20°C) DB in heating.
- Table does not reflect fan or pump power corrections for AHRI/ISO conditions.
- All performance is based upon the lower voltage of dual voltage rated units.
- Performance stated is at the rated power supply; performance may vary as the power supply varies from the rated.
- Operation below 40°F (10.0°C) EWT is based upon 20% methanol antifreeze solution.
- Operation below 60°F (15.5°C) EWT requires optional insulated water/refrigerant circuit.
- See performance correction tables for operating conditions other than those listed above.
- See Performance Data Selection Notes for operation in the shaded areas.
- Regular Cooling operation with an EWT of less than 50°F (10.0°C) is not recommended unless variable water flow is available.
- Regular Heating operation with an EWT of more than 90°F (32°C) is not recommended unless variable water flow is available.
- For quiet operation and long term reliability, it is recommended that systems be designed to avoid continuous operation in the outlined areas.
- Performance capacities shown in thousands of Btuh
- Hot Water Generator Capacity is based on 90°F entering water and 0.5 GPM/Ton.

Heat Controller works continually to improve its products. As a result, the design and specifications of each product at the time of order may be changed without notice and may not be as described herein. Please contact Heat Controller's Customer Service Department at 517-787-2100 for specific information on the current design and specifications. Statements and other information contained herein are not express warranties and do not form the basis of any bargain between the parties, but are merely Heat Controller's opinion or commendation of its products. The latest version of this document is available at www.heatcontroller.com. Engineered and assembled in the USA. © Heat Controller, Inc. All Rights Reserved 2024

Performance Data ME072 EC Blower Motor (Part Load)

Models:
ME
024-072

1,700 CFM Rated Airflow

EWT °F	WPD			Cooling - EAT 80/67°F							WPD			Heating - EAT 70°F						
	FLOW GPM	PSI	FT	TC	SC	kW	HR	EER	LWT	HWG Cap	FLOW GPM	PSI	FT	HC	kW	HE	COP	LWT	HWG Cap	
20	10.3	Operation Not Recommended										13.7	5.1	11.9	32.8	3.3	21.7	2.9	16.8	3.9
	13.7																			
30	6.9	1.6	3.7	60.0	42.8	1.8	66.3	32.4	49.2	1.9	6.9	1.6	3.7	36.4	3.3	25.1	3.2	22.7	4.2	
	10.3	3.1	7.2	57.9	40.6	1.7	63.8	33.1	42.4	1.8	10.3	3.1	7.2	37.7	3.3	26.3	3.3	24.9	4.3	
	13.7	4.6	10.7	56.5	39.2	1.7	62.3	33.0	39.1	1.7	13.7	4.6	10.7	38.3	3.4	26.9	3.4	26.1	4.4	
40	6.9	1.4	3.2	61.6	44.8	2.1	68.7	29.8	59.9	2.2	6.9	1.4	3.2	41.1	3.4	29.6	3.6	31.4	4.5	
	10.3	2.8	6.5	60.8	43.7	1.9	67.4	31.7	53.1	2.1	10.3	2.8	6.5	42.4	3.4	30.9	3.7	34.0	4.6	
	13.7	4.2	9.8	60.1	42.9	1.9	66.5	32.4	49.7	2.0	13.7	4.2	9.8	43.1	3.4	31.5	3.7	35.4	4.8	
50	6.9	1.3	2.9	61.4	45.5	2.4	69.4	26.1	70.1	2.7	6.9	1.3	2.9	45.4	3.4	33.9	3.9	40.2	4.9	
	10.3	2.6	6.0	61.7	45.2	2.2	69.1	28.6	63.4	2.6	10.3	2.6	6.0	46.8	3.4	35.3	4.1	43.1	5.1	
	13.7	3.9	9.0	61.6	44.9	2.1	68.7	29.7	60.0	2.5	13.7	3.9	9.0	47.6	3.4	36.1	4.1	44.7	5.2	
60	6.9	1.2	2.7	59.9	45.1	2.7	69.0	22.3	80.0	3.3	6.9	1.2	2.7	49.8	3.4	38.3	4.3	48.9	5.4	
	10.3	2.4	5.6	61.0	45.4	2.5	69.4	24.8	73.5	3.2	10.3	2.4	5.6	51.6	3.4	40.1	4.5	52.2	5.6	
	13.7	3.7	8.5	61.4	45.5	2.4	69.4	26.1	70.1	3.1	13.7	3.7	8.5	52.6	3.4	41.1	4.6	54.0	5.7	
70	6.9	1.1	2.5	57.4	44.0	3.1	67.9	18.7	89.7	4.1	6.9	1.1	2.5	54.7	3.4	43.1	4.7	57.5	6.0	
	10.3	2.3	5.3	59.1	44.8	2.8	68.7	21.0	83.3	4.0	10.3	2.3	5.3	57.2	3.4	45.5	4.9	61.2	6.2	
	13.7	3.5	8.1	59.9	45.1	2.7	69.0	22.3	80.1	3.9	13.7	3.5	8.1	58.6	3.4	46.9	5.0	63.2	6.4	
80	6.9	1.0	2.4	54.4	42.5	3.5	66.3	15.6	99.2	5.1	6.9	1.0	2.4	60.7	3.5	48.8	5.1	65.8	6.7	
	10.3	2.2	5.1	56.4	43.5	3.2	67.4	17.6	93.1	5.0	10.3	2.2	5.1	64.1	3.5	52.0	5.3	69.9	6.9	
	13.7	3.3	7.7	57.4	44.0	3.1	67.9	18.7	89.9	4.8	13.7	3.3	7.7	66.1	3.6	53.9	5.4	72.1	7.1	
85	6.9	1.0	2.3	52.7	41.7	3.7	65.4	14.1	104.0	6.0	6.9	1.0	2.3	64.1	3.5	52.0	5.3	69.9	7.0	
	10.3	2.1	5.0	54.8	42.7	3.4	66.5	16.0	97.9	5.7	10.3	2.1	5.0	68.2	3.6	55.8	5.5	74.2	7.3	
	13.7	3.3	7.6	55.8	43.2	3.3	67.1	17.0	94.8	5.5	13.7	3.3	7.6	70.6	3.7	58.0	5.6	76.5	7.4	
90	6.9	1.0	2.3	50.9	40.8	4.0	64.5	12.8	108.7	6.3	6.9	1.0	2.3	67.9	3.6	55.5	5.5	73.9	7.4	
	10.3	2.1	4.8	53.1	41.9	3.7	65.6	14.5	102.7	6.1	10.3	2.1	4.8	72.7	3.7	59.9	5.7	78.4	7.6	
	13.7	3.2	7.4	54.2	42.4	3.5	66.2	15.4	99.7	5.9	13.7	3.2	7.4	75.6	3.8	62.5	5.8	80.9	7.8	
100	6.9	0.9	2.1	47.3	39.2	4.5	62.7	10.5	118.2	7.6	Operation Not Recommended									
	10.3	2.0	4.6	49.5	40.2	4.2	63.7	11.9	112.4	7.4										
	13.7	3.1	7.1	50.7	40.7	4.0	64.3	12.6	109.4	7.1										
110	6.9	0.8	2.0	43.8	37.7	5.1	61.1	8.7	127.7	9.1										
	10.3	1.9	4.4	45.9	38.5	4.7	62.0	9.7	122.0	8.9										
	13.7	2.9	6.8	47.0	39.0	4.5	62.5	10.3	119.1	8.6										
120	6.9	0.7	1.7	40.7	36.7	5.7	60.1	7.2	137.4	10.8										
	10.3	1.7	4.0	42.5	37.2	5.3	60.6	8.0	131.8	10.5										
	13.7	2.7	6.3	43.4	37.5	5.1	61.0	8.5	128.9	10.2										

- Interpolation is permissible; extrapolation is not.
- All entering air conditions are 80°F (26.6°C) DB and 67°F (19.4°C) WB in cooling, and 70°F (21°C) DB in heating.
- AHRI/ISO certified conditions are 80.6°F (27°C) DB and 66.2°F (19°C) WB in cooling and 68°F (20°C) DB in heating.
- Table does not reflect fan or pump power corrections for AHRI/ISO conditions.
- All performance is based upon the lower voltage of dual voltage rated units.
- Performance stated is at the rated power supply; performance may vary as the power supply varies from the rated.
- Operation below 40°F (10.0°C) EWT is based upon 20% methanol antifreeze solution.
- Operation below 60°F (15.5°C) EWT requires optional insulated water/refrigerant circuit.
- See performance correction tables for operating conditions other than those listed above.
- See Performance Data Selection Notes for operation in the shaded areas.
- Regular Cooling operation with an EWT of less than 50°F (10.0°C) is not recommended unless variable water flow is available.
- Regular Heating operation with an EWT of more than 90°F (32°C) is not recommended unless variable water flow is available.
- For quiet operation and long term reliability, it is recommended that systems be designed to avoid continuous operation in the outlined areas.
- Performance capacities shown in thousands of Btuh
- Hot Water Generator Capacity is based on 90°F entering water and 0.5 GPM/Ton.

Heat Controller works continually to improve its products. As a result, the design and specifications of each product at the time of order may be changed without notice and may not be as described herein. Please contact Heat Controller's Customer Service Department at 517-787-2100 for specific information on the current design and specifications. Statements and other information contained herein are not express warranties and do not form the basis of any bargain between the parties, but are merely Heat Controller's opinion or commendation of its products. The latest version of this document is available at www.heatcontroller.com. Engineered and assembled in the USA. © Heat Controller, Inc. All Rights Reserved 2024

Performance Data ME072 EC Blower Motor (Full Load)

Models:
ME
024-072

1,900 CFM Rated Airflow

EWT °F	WPD			Cooling - EAT 80/67°F							WPD			Heating - EAT 70°F						
	FLOW GPM	PSI	FT	TC	SC	kW	HR	EER	LWT	HWG Cap	FLOW GPM	PSI	FT	HC	kW	HE	COP	LWT	HWG Cap	
20	12.8	Operation Not Recommended										17.0	7.6	17.7	47.9	4.2	33.5	3.3	16.1	4.2
	17.0																			
30	8.5	2.2	5.0	78.5	53.4	3.1	89.0	25.4	50.2	2.5	8.5	2.2	5.0	50.2	4.4	35.3	3.4	21.7	4.3	
	12.8	4.5	10.4	76.1	51.4	2.9	85.9	26.5	42.9	2.4	12.8	4.5	10.4	51.5	4.4	36.3	3.4	24.3	4.3	
	17.0	6.8	15.7	74.5	50.1	2.8	84.0	26.8	39.4	2.4	17.0	6.8	15.7	52.2	4.5	36.9	3.4	25.7	4.3	
40	8.5	1.9	4.3	79.9	54.9	3.4	91.4	23.5	61.1	2.5	8.5	1.9	4.3	55.0	4.6	39.2	3.5	30.8	4.5	
	12.8	4.0	9.3	79.1	54.0	3.2	89.9	24.9	53.7	2.5	12.8	4.0	9.3	56.7	4.7	40.7	3.5	33.6	4.5	
	17.0	6.1	14.2	78.3	53.3	3.1	88.8	25.5	50.1	2.4	17.0	6.1	14.2	57.6	4.7	41.5	3.6	35.1	4.6	
50	8.5	1.7	3.8	79.4	55.2	3.7	92.1	21.3	71.4	3.1	8.5	1.7	3.8	60.5	4.8	44.0	3.7	39.6	5.0	
	12.8	3.6	8.4	79.9	55.1	3.5	91.8	23.0	64.1	3.0	12.8	3.6	8.4	62.7	4.9	45.9	3.7	42.8	5.1	
	17.0	5.6	13.0	79.8	54.9	3.4	91.3	23.7	60.5	3.0	17.0	5.6	13.0	63.9	5.0	47.0	3.8	44.5	5.1	
60	8.5	1.5	3.4	77.6	54.5	4.1	91.6	19.0	81.2	4.6	8.5	1.5	3.4	66.8	5.1	49.5	3.9	48.4	5.8	
	12.8	3.4	7.8	79.0	55.1	3.8	92.1	20.7	74.2	4.4	12.8	3.4	7.8	69.5	5.2	51.8	3.9	51.9	6.5	
	17.0	5.2	12.1	79.5	55.2	3.7	92.1	21.5	70.7	4.2	17.0	5.2	12.1	70.9	5.2	53.2	4.0	53.7	7.1	
70	8.5	1.4	3.2	74.8	53.2	4.5	90.2	16.6	90.5	5.8	8.5	1.4	3.2	73.5	5.3	55.4	4.1	57.0	6.5	
	12.8	3.2	7.3	76.9	54.2	4.2	91.2	18.3	84.0	5.2	12.8	3.2	7.3	76.7	5.4	58.3	4.2	60.9	7.3	
	17.0	4.9	11.4	77.8	54.6	4.1	91.6	19.2	80.6	5.0	17.0	4.9	11.4	78.4	5.4	59.8	4.2	63.0	7.9	
80	8.5	1.3	3.0	71.3	51.4	5.0	88.3	14.3	99.6	7.2	8.5	1.3	3.0	80.5	5.5	61.7	4.3	65.5	7.1	
	12.8	3.0	7.0	73.8	52.7	4.6	89.7	15.9	93.5	6.7	12.8	3.0	7.0	84.2	5.6	65.0	4.4	69.8	7.9	
	17.0	4.7	10.9	75.0	53.3	4.5	90.3	16.7	90.3	6.3	17.0	4.7	10.9	86.2	5.7	66.8	4.4	72.1	8.7	
85	8.5	1.3	3.0	69.4	50.5	5.3	87.3	13.2	103.9	8.2	8.5	1.3	3.0	84.1	5.6	65.0	4.4	69.7	7.7	
	12.8	3.0	6.8	72.0	51.8	4.9	88.7	14.7	98.2	7.4	12.8	3.0	6.8	88.0	5.7	68.5	4.5	74.3	8.1	
	17.0	4.6	10.7	73.3	52.4	4.7	89.4	15.5	95.0	6.9	17.0	4.6	10.7	90.1	5.8	70.4	4.6	76.7	8.8	
90	8.5	1.3	2.9	67.4	49.5	5.6	86.3	12.1	108.2	9.1	8.5	1.3	2.9	87.7	5.7	68.2	4.5	73.9	8.1	
	12.8	2.9	6.7	70.1	50.8	5.2	87.7	13.6	102.7	8.3	12.8	2.9	6.7	91.8	5.8	71.9	4.6	78.7	8.5	
	17.0	4.5	10.5	71.5	51.5	5.0	88.4	14.4	99.8	7.4	17.0	4.5	10.5	94.1	5.9	73.9	4.7	81.3	8.9	
100	8.5	1.2	2.8	63.2	47.6	6.2	84.5	10.2	116.6	10.6	Operation Not Recommended									
	12.8	2.8	6.5	66.0	48.9	5.8	85.7	11.5	111.7	9.9										
	17.0	4.4	10.2	67.4	49.5	5.5	86.4	12.2	109.0	9.0										
110	8.5	1.2	2.7	59.2	45.8	7.0	83.0	8.5	124.7	12.3										
	12.8	2.7	6.3	61.8	46.9	6.5	83.9	9.6	120.5	11.7										
	17.0	4.3	9.9	63.2	47.6	6.2	84.4	10.2	118.1	10.6										
120	8.5	1.1	2.6	55.4	44.4	7.9	82.4	7.0	132.5	14.1										
	12.8	2.6	6.1	57.8	45.2	7.3	82.7	7.9	129.0	13.6										
	17.0	4.1	9.6	59.1	45.8	7.0	83.0	8.4	127.0	12.4										

- Interpolation is permissible; extrapolation is not.
- All entering air conditions are 80°F (26.6°C) DB and 67°F (19.4°C) WB in cooling, and 70°F (21°C) DB in heating.
- AHRI/ISO certified conditions are 80.6°F (27°C) DB and 66.2°F (19°C) WB in cooling and 68°F (20°C) DB in heating.
- Table does not reflect fan or pump power corrections for AHRI/ISO conditions.
- All performance is based upon the lower voltage of dual voltage rated units.
- Performance stated is at the rated power supply; performance may vary as the power supply varies from the rated.
- Operation below 40°F (10.0°C) EWT is based upon 20% methanol antifreeze solution.
- Operation below 60°F (15.5°C) EWT requires optional insulated water/refrigerant circuit.
- See performance correction tables for operating conditions other than those listed above.
- See Performance Data Selection Notes for operation in the shaded areas.
- Regular Cooling operation with an EWT of less than 50°F (10.0°C) is not recommended unless variable water flow is available.
- Regular Heating operation with an EWT of more than 90°F (32°C) is not recommended unless variable water flow is available.
- For quiet operation and long term reliability, it is recommended that systems be designed to avoid continuous operation in the outlined areas.
- Performance capacities shown in thousands of Btuh
- Hot Water Generator Capacity is based on 90°F entering water and 0.5 GPM/Ton.

Heat Controller works continually to improve its products. As a result, the design and specifications of each product at the time of order may be changed without notice and may not be as described herein. Please contact Heat Controller's Customer Service Department at 517-787-2100 for specific information on the current design and specifications. Statements and other information contained herein are not express warranties and do not form the basis of any bargain between the parties, but are merely Heat Controller's opinion or commendation of its products. The latest version of this document is available at www.heatcontroller.com. Engineered and assembled in the USA. © Heat Controller, Inc. All Rights Reserved 2024

Performance Data ME072 EC Blower Motor Modulating Flow (Part Load)

Models:
ME
024-072

1700 CFM Rated Airflow

EWT °F	WPD			COOLING - EAT 80/67 °F							WPD			HEATING - EAT 70°F					
	FLOW GPM	PSI	FT	TC	SC	kW	HR	EER	LWT	HWG Cap	FLOW GPM	PSI	FT	HC	kW	HE	COP	LWT	HWG Cap
20	10.3	Operation Not Recommended																	
	13.7	13.7	5.1	11.9	32.8	3.3	21.7	2.9	16.8	3.9									
30	6.9	0.6	1.4	63.8	46.5	2.0	70.6	31.9	60.0	1.9	6.9	1.6	3.7	36.4	3.3	25.1	3.2	22.7	4.2
	10.3	0.6	1.4	63.8	46.5	2.0	70.6	31.9	60.0	1.9	10.3	3.1	7.2	37.7	3.3	26.3	3.3	24.9	4.3
	13.7	0.6	1.4	63.8	46.5	2.0	70.6	31.9	60.0	1.9	13.7	4.6	10.7	38.3	3.4	26.9	3.4	26.1	4.4
40	6.9	1.4	3.2	61.6	44.9	2.1	68.7	29.8	60.0	1.9	6.9	1.4	3.2	41.1	3.4	29.6	3.6	31.4	4.5
	10.3	1.4	3.2	61.6	44.9	2.1	68.7	29.8	60.0	1.9	10.3	2.8	6.5	42.4	3.4	30.9	3.7	34.0	4.6
	13.7	1.4	3.2	61.6	44.9	2.1	68.7	29.8	60.0	1.9	13.7	4.2	9.8	43.1	3.4	31.5	3.7	35.4	4.8
50	6.9	1.3	2.9	61.4	45.5	2.4	69.4	26.1	70.1	2.7	6.9	1.3	2.9	45.4	3.4	33.9	3.9	40.2	4.9
	10.3	2.6	6.0	61.7	45.2	2.2	69.1	28.6	63.4	2.6	10.3	2.6	6.0	46.8	3.4	35.3	4.1	43.1	5.1
	13.7	3.9	9.0	61.6	44.9	2.1	68.7	29.7	60.0	2.5	13.7	3.9	9.0	47.6	3.4	36.1	4.1	44.7	5.2
60	6.9	1.2	2.7	59.9	45.1	2.7	69.0	22.3	80.0	3.3	6.9	1.2	2.7	49.8	3.4	38.3	4.3	48.9	5.4
	10.3	2.4	5.6	61.0	45.4	2.5	69.4	24.8	73.5	3.2	10.3	2.4	5.6	51.6	3.4	40.1	4.5	52.2	5.6
	13.7	3.7	8.5	61.4	45.5	2.4	69.4	26.1	70.1	3.1	13.7	3.7	8.5	52.6	3.4	41.1	4.6	54.0	5.7
70	6.9	1.1	2.5	57.4	44.0	3.1	67.9	18.7	89.7	4.1	6.9	1.1	2.5	54.7	3.4	43.1	4.7	57.5	6.0
	10.3	2.3	5.3	59.1	44.8	2.8	68.7	21.0	83.3	4.0	10.3	2.3	5.3	57.2	3.4	45.5	4.9	61.2	6.2
	13.7	3.5	8.1	59.9	45.1	2.7	69.0	22.3	80.1	3.9	13.7	3.5	8.1	58.6	3.4	46.9	5.0	63.2	6.4
80	6.9	1.0	2.4	54.4	42.5	3.5	66.3	15.6	99.2	5.1	6.9	1.0	2.4	60.7	3.5	48.8	5.1	65.8	6.7
	10.3	2.2	5.1	56.4	43.5	3.2	67.4	17.6	93.1	5.0	10.3	2.2	5.1	64.1	3.5	52.0	5.3	69.9	6.9
	13.7	3.3	7.7	57.4	44.0	3.1	67.9	18.7	89.9	4.8	13.7	3.3	7.7	66.1	3.6	53.9	5.4	72.1	7.1
85	6.9	1.0	2.3	52.7	41.7	3.7	65.4	14.1	104.0	6.0	6.9	1.0	2.3	64.1	3.5	52.0	5.3	69.9	7.0
	10.3	2.1	5.0	54.8	42.7	3.4	66.5	16.0	97.9	5.7	10.3	2.1	5.0	68.2	3.6	55.8	5.5	74.2	7.3
	13.7	3.3	7.6	55.8	43.2	3.3	67.1	17.0	94.8	5.5	13.7	3.3	7.6	70.6	3.7	58.0	5.6	76.5	7.4
90	6.9	1.0	2.3	50.9	40.8	4.0	64.5	12.8	108.7	6.3	6.9	1.0	2.3	67.9	3.6	55.5	5.5	73.9	7.4
	10.3	2.1	4.8	53.1	41.9	3.7	65.6	14.5	102.7	6.1	10.3	2.1	4.8	72.7	3.7	59.9	5.7	78.4	7.6
	13.7	3.2	7.4	54.2	42.4	3.5	66.2	15.4	99.7	5.9	13.7	3.2	7.4	75.6	3.8	62.5	5.8	80.9	7.8
100	6.9	0.9	2.1	47.3	39.2	4.5	62.7	10.5	118.2	7.6	3.4	0.1	0.2	63.5	3.5	51.6	5.3	70.0	7.4
	10.3	2.0	4.6	49.5	40.2	4.2	63.7	11.9	112.4	7.4	3.4	0.1	0.2	63.5	3.5	51.6	5.3	70.0	7.4
	13.7	3.1	7.1	50.7	40.7	4.0	64.3	12.6	109.4	7.1	3.4	0.1	0.2	63.5	3.5	51.6	5.3	70.0	7.4
110	6.9	0.8	2.0	43.8	37.7	5.1	61.1	8.7	127.7	9.1	2.6	0.1	0.2	63.5	3.5	51.6	5.3	70.0	7.4
	10.3	1.9	4.4	45.9	38.5	4.7	62.0	9.7	122.0	8.9	2.6	0.1	0.2	63.5	3.5	51.6	5.3	70.0	7.4
	13.7	2.9	6.8	47.0	39.0	4.5	62.5	10.3	119.1	8.6	2.6	0.1	0.2	63.5	3.5	51.6	5.3	70.0	7.4
120	6.9	0.7	1.7	40.7	36.7	5.7	60.1	7.2	137.4	10.8	2.1	0.1	0.2	63.5	3.5	51.6	5.3	70.0	7.4
	10.3	1.7	4.0	42.5	37.2	5.3	60.6	8.0	131.8	10.5	2.1	0.1	0.2	63.5	3.5	51.6	5.3	70.0	7.4
	13.7	2.7	6.3	43.4	37.5	5.1	61.0	8.5	128.9	10.2	2.1	0.1	0.2	63.5	3.5	51.6	5.3	70.0	7.4

- Interpolation is permissible; extrapolation is not.
- All entering air conditions are 80°F (26.6°C) DB and 67°F (19.4°C) WB in cooling, and 70°F (21°C) DB in heating.
- AHRI/ISO certified conditions are 80.6°F (27°C) DB and 66.2°F (19°C) WB in cooling and 68°F (20°C) DB in heating.
- Table does not reflect fan or pump power corrections for AHRI/ISO conditions.
- All performance is based upon the lower voltage of dual voltage rated units.
- Performance stated is at the rated power supply; performance may vary as the power supply varies from the rated.
- Operation below 40°F (10.0°C) EWT is based upon 20% methanol antifreeze solution.
- Operation below 60°F (15.5°C) EWT requires optional insulated water/refrigerant circuit.
- See performance correction tables for operating conditions other than those listed above.
- See Performance Data Selection Notes for operation in the shaded areas.
- Regular Cooling operation with an EWT of less than 50°F (10.0°C) is not recommended unless variable water flow is available.
- Regular Heating operation with an EWT of more than 90°F (32°C) is not recommended unless variable water flow is available.
- For quiet operation and long term reliability, it is recommended that systems be designed to avoid continuous operation in the outlined areas.
- Performance capacities shown in thousands of Btuh
- Hot Water Generator Capacity is based on 90°F entering water and 0.5 GPM/Ton.

Heat Controller works continually to improve its products. As a result, the design and specifications of each product at the time of order may be changed without notice and may not be as described herein. Please contact Heat Controller's Customer Service Department at 517-787-2100 for specific information on the current design and specifications. Statements and other information contained herein are not express warranties and do not form the basis of any bargain between the parties, but are merely Heat Controller's opinion or commendation of its products. The latest version of this document is available at www.heatcontroller.com. Engineered and assembled in the USA. © Heat Controller, Inc. All Rights Reserved 2024

Performance Data ME072 EC Blower Motor Modulating Flow (Full Load)

Models:
ME
024-072

1900 CFM Rated Airflow

EWT °F	WPD			COOLING - EAT 80/67 °F							WPD			HEATING - EAT 70°F						
	FLOW GPM	PSI	FT	TC	SC	kW	HR	EER	LWT	HWG Cap	FLOW GPM	PSI	FT	HC	kW	HE	COP	LWT	HWG Cap	
20	12.8	Operation Not Recommended																		
	17.0	17.0	7.6	17.7	47.9	4.2	33.5	3.3	16.1	4.2										
30	6.1	0.9	2.0	79.7	56.4	3.4	91.3	23.3	60.0	2.4	8.5	2.2	5.0	50.2	4.4	35.3	3.4	21.7	4.3	
	6.1	0.9	2.0	79.7	56.4	3.4	91.3	23.3	60.0	2.4	12.8	4.5	10.4	51.5	4.4	36.3	3.4	24.3	4.3	
	6.1	0.9	2.0	79.7	56.4	3.4	91.3	23.3	60.0	2.4	17.0	6.8	15.7	52.2	4.5	36.9	3.4	25.7	4.3	
40	8.9	2.1	4.8	77.8	54.8	3.4	89.3	23.1	60.0	2.4	8.5	1.9	4.3	55.0	4.6	39.2	3.5	30.8	4.5	
	8.9	2.1	4.8	77.8	54.8	3.4	89.3	23.1	60.0	2.4	12.8	4.0	9.3	56.7	4.7	40.7	3.5	33.6	4.5	
	8.9	2.1	4.8	77.8	54.8	3.4	89.3	23.1	60.0	2.4	17.0	6.1	14.2	57.6	4.7	41.5	3.6	35.1	4.6	
50	8.5	1.7	3.8	79.4	55.2	3.7	92.1	21.3	71.4	4.2	8.5	1.7	3.8	60.5	4.8	44.0	3.7	39.6	5.0	
	12.8	3.6	8.4	79.9	55.1	3.5	91.8	23.0	64.1	3.8	12.8	3.6	8.4	62.7	4.9	45.9	3.7	42.8	5.1	
	17.0	5.6	13.0	79.8	54.9	3.4	91.3	23.7	60.5	3.5	17.0	5.6	13.0	63.9	5.0	47.0	3.8	44.5	5.1	
60	8.5	1.5	3.4	77.6	54.5	4.1	91.6	19.0	81.2	4.6	8.5	1.5	3.4	66.8	5.1	49.5	3.9	48.4	5.8	
	12.8	3.4	7.8	79.0	55.1	3.8	92.1	20.7	74.2	4.4	12.8	3.4	7.8	69.5	5.2	51.8	3.9	51.9	6.5	
	17.0	5.2	12.1	79.5	55.2	3.7	92.1	21.5	70.7	4.2	17.0	5.2	12.1	70.9	5.2	53.2	4.0	53.7	7.1	
70	8.5	1.4	3.2	74.8	53.2	4.5	90.2	16.6	90.5	5.8	8.5	1.4	3.2	73.5	5.3	55.4	4.1	57.0	6.5	
	12.8	3.2	7.3	76.9	54.2	4.2	91.2	18.3	84.0	5.2	12.8	3.2	7.3	76.7	5.4	58.3	4.2	60.9	7.3	
	17.0	4.9	11.4	77.8	54.6	4.1	91.6	19.2	80.6	5.0	17.0	4.9	11.4	78.4	5.4	59.8	4.2	63.0	7.9	
80	8.5	1.3	3.0	71.3	51.4	5.0	88.3	14.3	99.6	7.2	8.5	1.3	3.0	80.5	5.5	61.7	4.3	65.5	7.1	
	12.8	3.0	7.0	73.8	52.7	4.6	89.7	15.9	93.5	6.7	12.8	3.0	7.0	84.2	5.6	65.0	4.4	69.8	7.9	
	17.0	4.7	10.9	75.0	53.3	4.5	90.3	16.7	90.3	6.3	17.0	4.7	10.9	86.2	5.7	66.8	4.4	72.1	8.7	
85	8.5	1.3	3.0	69.4	50.5	5.3	87.3	13.2	103.9	8.2	8.5	1.3	3.0	84.1	5.6	65.0	4.4	69.7	7.7	
	12.8	3.0	6.8	72.0	51.8	4.9	88.7	14.7	98.2	7.4	12.8	3.0	6.8	88.0	5.7	68.5	4.5	74.3	8.1	
	17.0	4.6	10.7	73.3	52.4	4.7	89.4	15.5	95.0	6.9	17.0	4.6	10.7	90.1	5.8	70.4	4.6	76.7	8.8	
90	8.5	1.3	2.9	67.4	49.5	5.6	86.3	12.1	108.2	9.1	6.5	0.1	0.2	84.4	5.6	65.2	4.4	70.0	8.8	
	12.8	2.9	6.7	70.1	50.8	5.2	87.7	13.6	102.7	8.3	6.5	0.1	0.2	84.4	5.6	65.2	4.4	70.0	8.8	
	17.0	4.5	10.5	71.5	51.5	5.0	88.4	14.4	99.8	7.4	6.5	0.1	0.2	84.4	5.6	65.2	4.4	70.0	8.8	
100	8.5	1.2	2.8	63.2	47.6	6.2	84.5	10.2	116.6	10.6	4.3	0.1	0.2	84.4	5.6	65.2	4.4	70.0	8.8	
	12.8	2.8	6.5	66.0	48.9	5.8	85.7	11.5	111.7	9.9	4.3	0.1	0.2	84.4	5.6	65.2	4.4	70.0	8.8	
	17.0	4.4	10.2	67.4	49.5	5.5	86.4	12.2	109.0	9.0	4.3	0.1	0.2	84.4	5.6	65.2	4.4	70.0	8.8	
110	8.5	1.2	2.7	59.2	45.8	7.0	83.0	8.5	124.7	12.3	3.3	0.1	0.2	84.4	5.6	65.2	4.4	70.0	8.8	
	12.8	2.7	6.3	61.8	46.9	6.5	83.9	9.6	120.5	11.7	3.3	0.1	0.2	84.4	5.6	65.2	4.4	70.0	8.8	
	17.0	4.3	9.9	63.2	47.6	6.2	84.4	10.2	118.1	10.6	3.3	0.1	0.2	84.4	5.6	65.2	4.4	70.0	8.8	
120	8.5	1.1	2.6	55.4	44.4	7.9	82.4	7.0	132.5	14.1	2.6	0.1	0.2	84.4	5.6	65.2	4.4	70.0	8.8	
	12.8	2.6	6.1	57.8	45.2	7.3	82.7	7.9	129.0	13.6	2.6	0.1	0.2	84.4	5.6	65.2	4.4	70.0	8.8	
	17.0	4.1	9.6	59.1	45.8	7.0	83.0	8.4	127.0	12.4	2.6	0.1	0.2	84.4	5.6	65.2	4.4	70.0	8.8	

- Interpolation is permissible; extrapolation is not.
- All entering air conditions are 80°F (26.6°C) DB and 67°F (19.4°C) WB in cooling, and 70°F (21°C) DB in heating.
- AHRI/ISO certified conditions are 80.6°F (27°C) DB and 66.2°F (19°C) WB in cooling and 68°F (20°C) DB in heating.
- Table does not reflect fan or pump power corrections for AHRI/ISO conditions.
- All performance is based upon the lower voltage of dual voltage rated units.
- Performance stated is at the rated power supply; performance may vary as the power supply varies from the rated.
- Operation below 40°F (10.0°C) EWT is based upon 20% methanol antifreeze solution.
- Operation below 60°F (15.5°C) EWT requires optional insulated water/refrigerant circuit.
- See performance correction tables for operating conditions other than those listed above.
- See Performance Data Selection Notes for operation in the shaded areas.
- Regular Cooling operation with an EWT of less than 50°F (10.0°C) is not recommended unless variable water flow is available.
- Regular Heating operation with an EWT of more than 90°F (32°C) is not recommended unless variable water flow is available.
- For quiet operation and long term reliability, it is recommended that systems be designed to avoid continuous operation in the outlined areas.
- Performance capacities shown in thousands of Btuh
- Hot Water Generator Capacity is based on 90°F entering water and 0.5 GPM/Ton.

Heat Controller works continually to improve its products. As a result, the design and specifications of each product at the time of order may be changed without notice and may not be as described herein. Please contact Heat Controller's Customer Service Department at 517-787-2100 for specific information on the current design and specifications. Statements and other information contained herein are not express warranties and do not form the basis of any bargain between the parties, but are merely Heat Controller's opinion or commendation of its products. The latest version of this document is available at www.heatcontroller.com. Engineered and assembled in the USA. © Heat Controller, Inc. All Rights Reserved 2024

CV EC MOTOR ADVANTAGE

A major benefit of the CV EC motor over other blower motor types is its ability to adjust airflow directly at the unit with the Wireless Service Tool. Airflow levels can be adjusted in increments of 25 CFM from the unit's minimum and maximum CFM range (see the **CV EC motor configuration** table for details).

Blower Performance: CV EC Blower Motor Standard Unit

Model	Max ESP (in wg)	Range	Cooling Mode		Dehumid Mode		Heating Mode		Fan Only Mode	Aux Emergency Mode
			Stage 2	Stage 1	Stage 2	Stage 1	Stage 2	Stage 1		
ME024	1.0	Minimum	600	450	600	350	600	450	300	700
		Default	800	700	650	550	800	700	350	850
		Maximum	1,000	800	1,000	650	1,000	800	850	1,000
ME036	0.9	Minimum	900	600	900	475	900	600	450	1,350
		Default	1,200	1,000	975	800	1,200	1000	525	1,350
		Maximum	1,500	1,200	1,500	975	1,500	1200	1,250	1,500
ME048	1.0	Minimum	1,200	900	1,200	725	1,200	900	600	1,350
		Default	1,600	1,500	1,275	1,200	1,600	1,500	700	1,500
		Maximum	2,000	1,700	2,000	1,350	2,000	1,700	1,700	2,000
ME060	0.7	Minimum	1,500	1,200	1,500	950	1,500	1,200	750	1,500
		Default	1,900	1,700	1,525	1,350	1,900	1,700	875	1,875
		Maximum	2,100	1,900	2,100	1,525	2,500	1,900	2,100	2,300
ME072	0.7	Minimum	1,800	1,200	1,500	950	1,800	1,200	750	1,800
		Default	1,900	1,700	1,525	1,350	1,900	1,700	875	2,000
		Maximum	2,100	1,900	2,100	1,525	2,100	1,900	2,100	2,300

- Blower performance data is based on the lowest nameplate voltage setting.
- Blower performance is based on a wet coil with clean 1-inch filter.
- Blower performance is based on operating conditions of 80°F DB and 67°F WB.
- Airflow is controller within ±5% up to max ESP shown with wet coil and standard 1" fiberglass air filter.
- Cells in grey - option not available

Units with External Pump Only

Model	Voltage Code	Rated Voltage	Voltage Min/Max	Compressor				Fan Motor FLA	Pump	Total Unit FLA	Min Circ Amp	Fuse HACR
				MCC	RLA	LRA	Qty		External			
ME024	G.J.	208/230-1-60	187/252	16.0	10.3	62.0	1	4.2	4	18.5	21.1	30
ME036	G.J.	208/230-1-60	187/252	22.7	14.6	76.0	1	4.2	4	22.8	26.5	40
ME048	G.J.	208/230-1-60	187/252	28.6	18.3	138.0	1	7.5	4	29.8	34.4	50
ME060	J.	208/230-1-60	187/252	34.8	22.3	149.0	1	7.5	4	33.8	39.4	60
ME072	J.	208/230-1-60	187/252	43.7	28.0	166.0	1	7.5	4	39.5	46.5	70

Units with External Pump and HWG (no Internal Flow Controller)

Model	Voltage Code	Rated Voltage	Voltage Min/Max	Compressor				Fan Motor FLA	Pump		Total Unit FLA	Min Circ Amp	Fuse HACR
				MCC	RLA	LRA	Qty		External	HWG FLA			
ME024	G.J.	208/230-1-60	187/252	16.0	10.3	62.0	1	4.2	4	0.28	18.8	21.4	30
ME036	G.J.	208/230-1-60	187/252	22.7	14.6	76.0	1	4.2	4	0.28	23.1	26.7	40
ME048	G.J.	208/230-1-60	187/252	28.6	18.3	138.0	1	7.5	4	0.28	30.1	34.7	50
ME060	J.	208/230-1-60	187/252	34.8	22.3	149.0	1	7.5	4	0.28	34.1	39.7	60
ME072	J.	208/230-1-60	187/252	43.7	28.0	166.0	1	7.5	4	0.28	39.8	46.8	70

Units with Internal Flow Controller and HWG with Pump - Standard Head Variable Pump

Model	Voltage Code	Rated Voltage	Voltage Min/Max	Compressor				Fan Motor FLA	Pump		Total Unit FLA	Min Circ Amp	Fuse HACR
				MCC	RLA	LRA	Qty		Motor FLA	HWG FLA			
ME024	G.J.	208/230-1-60	187/252	16.0	10.3	62.0	1	4.2	0.64	0.28	15.4	18.0	25
ME036	G.J.	208/230-1-60	187/252	22.7	14.6	76.0	1	4.2	0.64	0.28	19.7	23.4	35
ME048	G.J.	208/230-1-60	187/252	28.6	18.3	138.0	1	7.5	0.64	0.28	26.7	31.3	45
ME060	J.	208/230-1-60	187/252	34.8	22.3	149.0	1	7.5	0.64	0.28	30.7	36.3	50
ME072	J.	208/230-1-60	187/252	43.7	28.0	166.0	1	7.5	0.64	0.28	36.4	43.4	70

Units with Internal Flow Controller with Pump - Standard Head Variable Pump

Model	Voltage Code	Rated Voltage	Voltage Min/Max	Compressor				Fan Motor FLA	Pump	Total Unit FLA	Min Circ Amp	Fuse HACR
				MCC	RLA	LRA	Qty		Motor FLA			
ME024	G.J.	208/230-1-60	187/252	16.0	10.3	62.0	1	4.2	0.64	15.1	17.7	25
ME036	G.J.	208/230-1-60	187/252	22.7	14.6	76.0	1	4.2	0.64	19.4	23.1	35
ME048	G.J.	208/230-1-60	187/252	28.6	18.3	138.0	1	7.5	0.64	26.4	31.0	45
ME060	J.	208/230-1-60	187/252	34.8	22.3	149.0	1	7.5	0.64	30.4	36.0	50
ME072	J.	208/230-1-60	187/252	43.7	28.0	166.0	1	7.5	0.64	36.1	43.1	70

Heat Controller works continually to improve its products. As a result, the design and specifications of each product at the time of order may be changed without notice and may not be as described herein. Please contact Heat Controller's Customer Service Department at 517-787-2100 for specific information on the current design and specifications. Statements and other information contained herein are not express warranties and do not form the basis of any bargain between the parties, but are merely Heat Controller's opinion or commendation of its products. The latest version of this document is available at www.heatcontroller.com. Engineered and assembled in the USA. © Heat Controller, Inc. All Rights Reserved 2024

Units with Internal Flow Controller and HWG with Pump - High Head Variable Pump

Model	Voltage Code	Rated Voltage	Voltage Min/Max	Compressor				Fan Motor FLA	Pump		Total Unit FLA	Min Circ Amp	Fuse HACR
				MCC	RLA	LRA	Qty		Motor FLA	HWG FLA			
ME024	G.J.	208/230-1-60	187/252	16.0	10.3	62.0	1	4.2	1.44	0.28	16.2	18.8	25
ME036	G.J.	208/230-1-60	187/252	22.7	14.6	76.0	1	4.2	1.44	0.28	20.5	24.2	35
ME048	G.J.	208/230-1-60	187/252	28.6	18.3	138.0	1	7.5	1.44	0.28	27.5	32.1	50
ME060	J.	208/230-1-60	187/252	34.8	22.3	149.0	1	7.5	1.44	0.28	31.5	37.1	50
ME072	J.	208/230-1-60	187/252	43.7	28.0	166.0	1	7.5	1.44	0.28	37.2	44.2	70

Units with Internal Flow Controller with Pump - High Head Variable Pump

Model	Voltage Code	Rated Voltage	Voltage Min/Max	Compressor				Fan Motor FLA	Pump	Total Unit FLA	Min Circ Amp	Fuse HACR
				MCC	RLA	LRA	Qty		Motor FLA			
ME024	G.J.	208/230-1-60	187/252	16.0	10.3	62.0	1	4.2	1.44	15.9	18.5	25
ME036	G.J.	208/230-1-60	187/252	22.7	14.6	76.0	1	4.2	1.44	20.2	23.9	35
ME048	G.J.	208/230-1-60	187/252	28.6	18.3	138.0	1	7.5	1.44	27.2	31.8	50
ME060	J.	208/230-1-60	187/252	34.8	22.3	149.0	1	7.5	1.44	31.2	36.8	50
ME072	J.	208/230-1-60	187/252	43.7	28.0	166.0	1	7.5	1.44	36.9	43.9	70

High Head and Standard Variable Pump Performance

Models:
ME
024-072

Standard Head Variable Pump Performance

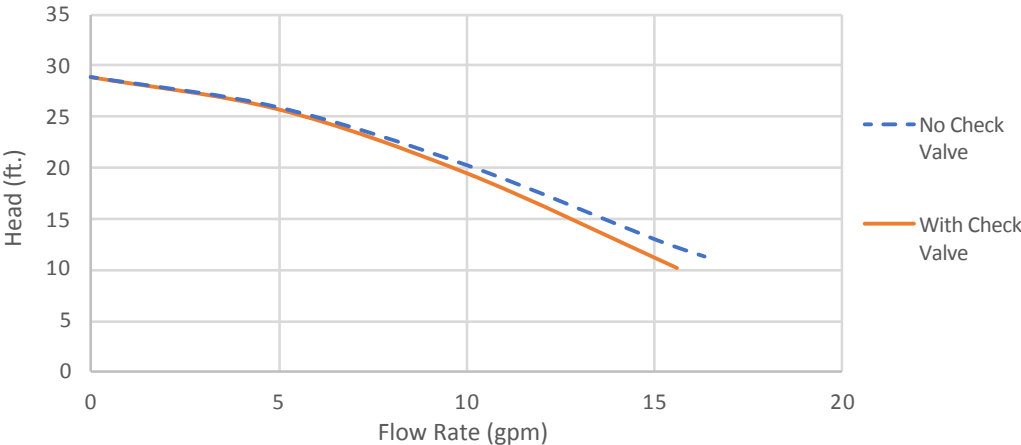

High Head Variable Pump Performance

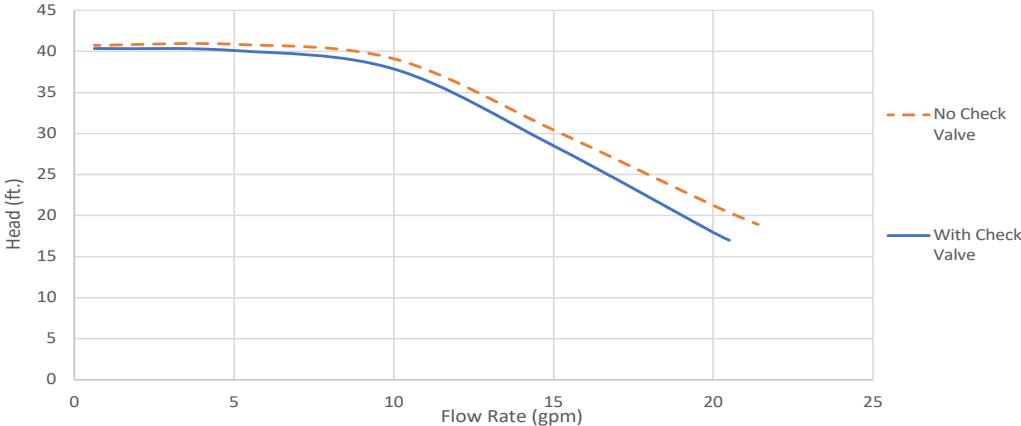

Heat Controller works continually to improve its products. As a result, the design and specifications of each product at the time of order may be changed without notice and may not be as described herein. Please contact Heat Controller's Customer Service Department at 517-787-2100 for specific information on the current design and specifications. Statements and other information contained herein are not express warranties and do not form the basis of any bargain between the parties, but are merely Heat Controller's opinion or commendation of its products. The latest version of this document is available at www.heatcontroller.com. Engineered and assembled in the USA. © Heat Controller, Inc. All Rights Reserved 2024

Corrections Part Load Performance Tables

Models:
ME
024-072

Cooling Correction

Entering Air WB °F	Total Capacity	Sensible Cooling Capacity Multipliers - Entering DB °F									Power	Heat of Rejection
		65	70	75	80	80.6	85	90	95	100		
50	0.883	1.099	1.241	*	*	*	*	*	*	*	0.985	0.901
55	0.903	0.871	1.060	1.271	*	*	*	*	*	*	0.989	0.918
60	0.935	0.617	0.844	1.079	1.319	1.349	*	*	*	*	0.993	0.945
65	0.979		0.595	0.849	1.096	1.128	1.342	*	*	*	0.998	0.982
66.2	0.991		0.531	0.789	1.040	1.070	1.284	1.522	*	*	0.999	0.993
67	1.000		0.486	0.747	1.000	1.030	1.245	1.481	*	*	1.000	1.000
70	1.035			0.583	0.842	0.873	1.090	1.327	1.552	*	1.003	1.030
75	1.105				0.552	0.584	0.811	1.057	1.290	1.510	1.008	1.088

Notes:

- AHRI/ISO/ASHRAE 13256-1 uses entering air conditions of Cooling - 80.6°F (27°C) DB/ 66.2°F (19°C) WB, and Heating 68°F (20°C) DB/ 59°F (15°C) WB entering air temperature.
- Asterisks indicate that no correction factor is needed, Total Capacity equals Sensible capacity.
- Entering DB temperature range is based on operating limits, not on commissioning limits.
- Cooling and heating air corrections based on rated airflow.

Heating Correction

Entering Air WB °F	Heating Capacity	Power	Heat of Rejection
40	1.084	0.732	1.161
45	1.073	0.764	1.140
50	1.060	0.802	1.117
55	1.046	0.846	1.090
60	1.031	0.893	1.061
65	1.016	0.945	1.031
68	1.006	0.978	1.013
70	1.000	1.000	1.000
75	0.984	1.058	0.968
80	0.968	1.117	0.936

Airflow Correction

Airflow % of Rated	Cooling				Heating		
	Total Capacity	Sensible Capacity	Power	Heat of Rejection	Heating Capacity	Power	Heat of Extraction
60%	0.920	0.781	0.959	0.927	0.946	1.241	0.881
69%	0.942	0.832	0.964	0.946	0.960	1.163	0.915
75%	0.956	0.867	0.696	0.959	0.969	1.115	0.937
81%	0.969	0.901	0.975	0.970	0.978	1.076	0.956
88%	0.981	0.934	0.982	0.981	0.986	1.043	0.973
94%	0.991	0.967	0.990	0.991	0.993	1.018	0.988
100%	1.000	1.000	1.000	1.000	1.000	1.000	1.000
106%	1.007	1.033	1.011	1.008	1.006	0.990	1.010
113%	1.013	1.065	1.023	1.015	1.012	0.986	1.017
119%	1.018	1.098	1.036	1.021	1.017	0.983	1.024
125%	1.021	1.131	1.051	1.026	1.021	0.981	1.030
130%	1.023	1.159	1.063	1.030	1.024	0.979	1.034

Heat Controller works continually to improve its products. As a result, the design and specifications of each product at the time of order may be changed without notice and may not be as described herein. Please contact Heat Controller's Customer Service Department at 517-787-2100 for specific information on the current design and specifications. Statements and other information contained herein are not express warranties and do not form the basis of any bargain between the parties, but are merely Heat Controller's opinion or commendation of its products. The latest version of this document is available at www.heatcontroller.com. Engineered and assembled in the USA. © Heat Controller, Inc. All Rights Reserved 2024

Corrections Full Load Performance Tables

Models:
ME
024-072

Cooling Correction

Entering Air WB °F	Total Capacity	Sensible Cooling Capacity Multipliers - Entering DB °F									Power	Heat of Rejection
		65	70	75	80	80.6	85	90	95	100		
50	0.850	1.174	*	*	*	*	*	*	*	*	0.953	0.87
55	0.880	0.902	1.115	*	*	*	*	*	*	*	0.964	0.896
60	0.922	0.646	0.875	1.103	1.329	*	*	*	*	*	0.977	0.932
65	0.975		0.639	0.869	1.096	1.123	1.320	*	*	*	0.993	0.979
66.2	0.990		0.582	0.812	1.039	1.066	1.262	*	*	*	0.997	0.991
67	1.000		0.545	0.774	1.000	1.027	1.223	1.444	*	*	1.000	1.000
70	1.040			0.630	0.853	0.880	1.075	1.297	*	*	1.011	1.035
75	1.117				0.601	0.627	0.821	1.046	1.275	1.510	1.033	1.101

Notes:

- AHRI/ISO/ASHRAE 13256-1 uses entering air conditions of Cooling - 80.6°F (27°C) DB/ 66.2°F (19°C) WB, and Heating 68°F (20°C) DB/ 59°F (15°C) WB entering air temperature.
- Asterisks indicate that no correction factor is needed, Total Capacity equals Sensible capacity.
- Entering DB temperature range is based on operating limits, not on commissioning limits.
- Cooling and heating air corrections based on rated airflow.

Heating Correction

Entering Air WB °F	Heating Capacity	Power	Heat of Rejection
40	1.052	0.779	1.120
45	1.043	0.808	1.102
50	1.035	0.841	1.084
55	1.027	0.877	1.065
60	1.019	0.915	1.045
65	1.010	0.957	1.023
68	1.004	0.982	1.010
70	1.000	1.000	1.000
75	0.989	1.045	0.974
80	0.976	1.093	0.946

Airflow Correction

Airflow % of Rated	Cooling				Heating		
	Total Capacity	Sensible Capacity	Power	Heat of Rejection	Heating Capacity	Power	Heat of Extraction
60%	0.925	0.788	0.913	0.922	0.946	1.153	0.896
69%	0.946	0.829	0.926	0.942	0.959	1.107	0.924
75%	0.960	0.861	0.937	0.955	0.969	1.078	0.942
81%	0.972	0.895	0.950	0.968	0.977	1.053	0.959
88%	0.983	0.930	0.965	0.979	0.985	1.032	0.974
94%	0.992	0.965	0.982	0.990	0.993	1.014	0.988
100%	1.000	1.000	1.000	1.000	1.000	1.000	1.000
106%	1.007	1.033	1.020	1.009	1.006	0.989	1.011
113%	1.012	1.064	1.042	1.018	1.012	0.982	1.019
119%	1.016	1.092	1.066	1.025	1.018	0.979	1.027
125%	1.018	1.116	1.091	1.032	1.022	0.977	1.033
130%	1.019	1.132	1.112	1.037	1.026	0.975	1.038

Heat Controller works continually to improve its products. As a result, the design and specifications of each product at the time of order may be changed without notice and may not be as described herein. Please contact Heat Controller's Customer Service Department at 517-787-2100 for specific information on the current design and specifications. Statements and other information contained herein are not express warranties and do not form the basis of any bargain between the parties, but are merely Heat Controller's opinion or commendation of its products. The latest version of this document is available at www.heatcontroller.com. Engineered and assembled in the USA. © Heat Controller, Inc. All Rights Reserved 2024

Corrections Antifreeze Table

Models:
ME
024-072

EWT (°F)	Antifreeze Type	Antifreeze %	Cooling			Heating		WPD
			Total Cap	Sensible Cap	Watts	Total Cap	Watts	
90	Water	0%	1.000	1.000	1.000	1.000	1.000	1.000
	Ethanol	5%	0.998	0.998	1.002	0.996	0.999	1.025
		10%	0.996	0.996	1.003	0.991	0.997	1.048
		15%	0.994	0.994	1.005	0.987	0.996	1.098
		20%	0.991	0.991	1.006	0.982	0.994	1.142
		25%	0.986	0.986	1.009	0.972	0.991	1.207
		30%	0.981	0.981	1.012	0.962	0.988	1.265
		35%	0.977	0.977	1.015	0.953	0.985	1.312
		40%	0.972	0.972	1.018	0.943	0.982	1.370
		45%	0.966	0.966	1.023	0.931	0.978	1.431
		50%	0.959	0.959	1.027	0.918	0.974	1.494
	Ethylene Glycol	5%	0.998	0.998	1.002	0.996	0.999	1.021
		10%	0.996	0.996	1.003	0.991	0.997	1.040
		15%	0.994	0.994	1.004	0.987	0.996	1.079
		20%	0.991	0.991	1.005	0.982	0.995	1.114
		25%	0.988	0.988	1.008	0.976	0.993	1.146
		30%	0.985	0.985	1.010	0.969	0.990	1.175
		35%	0.982	0.982	1.012	0.963	0.988	1.208
		40%	0.979	0.979	1.014	0.956	0.986	1.243
		45%	0.976	0.976	1.016	0.950	0.984	1.278
		50%	0.972	0.972	1.018	0.943	0.982	1.314
	Methanol	5%	0.997	0.997	1.002	0.993	0.998	1.039
		10%	0.993	0.993	1.004	0.986	0.996	1.075
		15%	0.990	0.990	1.007	0.979	0.994	1.116
		20%	0.986	0.986	1.009	0.972	0.991	1.154
		25%	0.982	0.982	1.012	0.964	0.989	1.189
		30%	0.978	0.978	1.014	0.955	0.986	1.221
		35%	0.974	0.974	1.017	0.947	0.984	1.267
		40%	0.970	0.970	1.020	0.939	0.981	1.310
		45%	0.966	0.966	1.023	0.930	0.978	1.353
		50%	0.961	0.961	1.026	0.920	0.975	1.398
	Propylene Glycol	5%	0.995	0.995	1.003	0.990	0.997	1.065
		10%	0.990	0.990	1.006	0.980	0.994	1.119
		15%	0.986	0.986	1.009	0.971	0.991	1.152
		20%	0.981	0.981	1.012	0.962	0.988	1.182
		25%	0.978	0.978	1.014	0.956	0.986	1.227
		30%	0.975	0.975	1.016	0.950	0.984	1.267
		35%	0.972	0.972	1.018	0.944	0.982	1.312
		40%	0.969	0.969	1.020	0.938	0.980	1.356
		45%	0.965	0.965	1.023	0.929	0.977	1.402
		50%	0.960	0.960	1.026	0.919	0.974	1.450

Table continued on next page

Heat Controller works continually to improve its products. As a result, the design and specifications of each product at the time of order may be changed without notice and may not be as described herein. Please contact Heat Controller's Customer Service Department at 517-787-2100 for specific information on the current design and specifications. Statements and other information contained herein are not express warranties and do not form the basis of any bargain between the parties, but are merely Heat Controller's opinion or commendation of its products. The latest version of this document is available at www.heatcontroller.com. Engineered and assembled in the USA. © Heat Controller, Inc. All Rights Reserved 2024

Corrections Antifreeze Table

Models:
ME
024-072

Table continued from previous page

EWT (°F)	Antifreeze Type	Antifreeze %	Cooling			Heating		WPD
			Total Cap	Sensible Cap	Watts	Total Cap	Watts	
30	Water	0%	1.000	1.000	1.000	1.000	1.000	1.000
	Ethanol	5%	0.991	0.991	1.006	0.981	0.994	1.140
		10%	0.981	0.981	1.012	0.961	0.988	1.242
		15%	0.973	0.973	1.018	0.944	0.983	1.295
		20%	0.964	0.964	1.024	0.927	0.977	1.343
		25%	0.959	0.959	1.028	0.917	0.974	1.363
		30%	0.954	0.954	1.031	0.907	0.970	1.383
		35%	0.949	0.949	1.035	0.897	0.967	1.468
		40%	0.944	0.944	1.038	0.887	0.964	1.523
		45%	0.940	0.940	1.041	0.880	0.962	1.580
	50%	0.936	0.936	1.043	0.872	0.959	1.639	
	Ethylene Glycol	5%	0.997	0.997	1.002	0.993	0.998	1.040
		10%	0.993	0.993	1.004	0.986	0.996	1.075
		15%	0.990	0.990	1.006	0.980	0.994	1.122
		20%	0.987	0.987	1.008	0.973	0.992	1.163
		25%	0.983	0.983	1.011	0.966	0.990	1.195
		30%	0.979	0.979	1.013	0.958	0.987	1.225
		35%	0.976	0.976	1.016	0.951	0.985	1.279
		40%	0.972	0.972	1.018	0.943	0.982	1.324
		45%	0.969	0.969	1.021	0.937	0.980	1.371
	50%	0.966	0.966	1.023	0.930	0.978	1.419	
	Methanol	5%	0.995	0.995	1.004	0.989	0.997	1.069
		10%	0.989	0.989	1.007	0.978	0.993	1.127
		15%	0.984	0.984	1.011	0.968	0.990	1.164
		20%	0.979	0.979	1.014	0.957	0.986	1.197
		25%	0.975	0.975	1.017	0.949	0.984	1.216
		30%	0.971	0.971	1.019	0.941	0.981	1.235
		35%	0.967	0.967	1.022	0.933	0.979	1.286
		40%	0.963	0.963	1.025	0.924	0.976	1.323
		45%	0.959	0.959	1.028	0.917	0.974	1.360
	50%	0.955	0.955	1.030	0.910	0.971	1.399	
	Propylene Glycol	5%	0.995	0.995	1.004	0.989	0.997	1.071
		10%	0.989	0.989	1.007	0.978	0.993	1.130
		15%	0.985	0.985	1.010	0.968	0.990	1.206
		20%	0.980	0.980	1.013	0.958	0.987	1.270
		25%	0.974	0.974	1.017	0.947	0.983	1.359
		30%	0.968	0.968	1.021	0.935	0.979	1.433
		35%	0.963	0.963	1.025	0.924	0.976	1.522
		40%	0.957	0.957	1.029	0.913	0.972	1.614
		45%	0.949	0.949	1.034	0.898	0.967	1.712
	50%	0.941	0.941	1.039	0.882	0.962	1.816	

Heat Controller works continually to improve its products. As a result, the design and specifications of each product at the time of order may be changed without notice and may not be as described herein. Please contact Heat Controller's Customer Service Department at 517-787-2100 for specific information on the current design and specifications. Statements and other information contained herein are not express warranties and do not form the basis of any bargain between the parties, but are merely Heat Controller's opinion or commendation of its products. The latest version of this document is available at www.heatcontroller.com. Engineered and assembled in the USA. © Heat Controller, Inc. All Rights Reserved 2024

Corrections Water Pressure Drop Table

Models:
ME
024-072

System Pressure Drop Valve

Model	GPM	Low System Pressure Drop Valve (Adders)					High System Pressure Drop Valve (Adders)				
		CV	Close Off	MOPD	PSI	FT	CV	Close Off	MOPD	PSI	FT
ME024	3.00	4.7	200	30	0.41	0.94	4.7	200	30	0.41	0.94
	4.50				0.92	2.12				0.92	2.12
	6.00				1.63	3.76				1.63	3.76
ME036	4.50	7.4	200	30	0.37	0.85	4.7	200	30	0.92	2.12
	6.80				0.84	1.95				2.09	4.84
	9.00				1.48	3.42				3.67	8.47
ME048	6.00	10	200	30	0.36	0.83	4.7	200	30	1.63	3.76
	9.00				0.81	1.87				3.67	8.47
	12.00				1.44	3.33				6.52	15.06
ME060	7.50	19	200	30	0.16	0.36	7.4	200	30	1.03	2.37
	11.30				0.35	0.82				2.33	5.39
	15.00				0.62	1.44				4.11	9.49
ME072	8.50	19	200	30	0.20	0.46	7.4	200	30	1.32	3.05
	12.80				0.45	1.05				2.99	6.91
	17.00				0.80	1.85				5.28	12.19

Heat Controller works continually to improve its products. As a result, the design and specifications of each product at the time of order may be changed without notice and may not be as described herein. Please contact Heat Controller's Customer Service Department at 517-787-2100 for specific information on the current design and specifications. Statements and other information contained herein are not express warranties and do not form the basis of any bargain between the parties, but are merely Heat Controller's opinion or commendation of its products. The latest version of this document is available at www.heatcontroller.com. Engineered and assembled in the USA. © Heat Controller, Inc. All Rights Reserved 2024

ME Series

Model	024	036	048	060	072
Factory Charge R-454B - (oz.)	34	43	59	102	109
Refrigerant Leak Detection System	O	O	O	R	R
Number of Sensors	2	2	2	2	2
Water Connection Size					
Swivel	1"	1"	1"	1"	1"
System Water Volume (gallons) ¹	0.65	0.74	0.89	0.94	0.94
Vertical					
Filter Standard - 2" Throwaway	28 x 24	28 x 29.5	32 x 29.5	36 x 29.5	36 x 29.5
Weight - Operating (lbs.)	298.0	359.0	448.0	475.0	475.0
Weight - Packaged (lbs.)	208.0	369.0	458.0	485.0	485.0
Horizontal					
Filter Standard - 2" Throwaway	2 - 18 x 18	1 - 12 x 20 1 - 20 x 25	1 - 18 x 20 1 - 20 x 24	2 - 20 x 24	2 - 20 x 24
Weight - Operating (lbs.)	298.0	359.0	448.0	475.0	475.0
Weight - Packaged (lbs.)	308.0	369.0	458.0	485.0	485.0
Downflow					
Filter Standard - 2" Throwaway	28.0 x 24.0	28.0 x 29.5	32.0 x 29.5	36.0 x 29.5	36.0 x 29.5
Weight - Operating (lbs.)	298.0	359.0	448.0	475.0	475.0
Weight - Packaged (lbs.)	308.0	369.0	458.0	485.0	485.0
Hot Water Generator					
Swivel - Residential Class	1"	1"	1"	1"	1"
Weight - HWG Adder (lbs.)	313.0	374.0	463.0	490.0	490.0

Notes:

- All dimensions displayed above are in inches unless otherwise marked.
- All units have TXV expansion device and ½-inch and ¾-inch electrical knockouts.
- The stainless-steel condensate drain connection is ¾-inch MPT.
- MPT = Male Pipe Thread
- O = Optional, R = Required
- 1. Volume without water options.

Unit Maximum Water Working Pressure

Options	Max Pressure PSIG [kPa]
Base Unit	300 [2,068]
Internal Modulating Valve	300 [2,068]
Internal Variable-Speed Pump	145 [1,000]

Dimensional Data Standard Dimensional Tables

Models:
ME
024-072

Cabinet Dimensions (inch)

Model	Cabinet Config	Depth/Length	Width	Height
		A	B	C
ME024	H	62.2	22.4	19.3
	V	25.6	22.4	48.5
	D	25.6	22.4	52.4
ME036	H	71.2	25.4	21.3
	V	30.6	25.4	50.5
	D	30.6	25.4	54.3
ME048	H	76.2	25.4	21.3
	V	30.6	25.4	54.5
	D	30.6	25.4	58.3
ME060- ME072	H	81.2	25.4	21.3
	V	30.6	25.4	58.5
	D	30.6	25.4	62.3

Electrical Knockouts (inch)

Model	Cabinet Config	H	Low Voltage	High Voltage	G
			J KO 1/2"	K KO 3/4"	
ME024	H	4.1	3.6	8.6	1.3
	V	4.1	3.6	8.6	1.3
	D	37.4	40.4	47.9	1.3
ME036	H	4.1	3.6	8.6	1.3
	V	4.1	3.6	8.6	1.3
	D	37.4	40.3	50.0	1.3
ME048	H	4.1	3.6	8.6	1.3
	V	4.1	3.6	8.6	1.3
	D	41.3	48.4	54.0	1.3
ME060- ME072	H	4.1	3.6	8.6	1.3
	V	4.1	3.6	8.6	1.3
	D	45.4	48.4	58.1	1.3

Shipping Dimensions and Water Connections (inch)

Model	Cabinet Config	Shipping Dimensions			Water Connections										Condensate Drain Pan		
		Depth/Length	Width	Height	Water In		Water Out		Water In/Out		HWG In		HWG Out		AA	BB	Condensate Drain Pan Fitting (MPT)
		A	B	C	D	E	F	E	Com ¹	Res ²	DD	EE	FF	EE			
ME024	H	67.5	28.4	23.7	3.9	1.7	8.4	1.7	3/4"	1"	13.9	1.6	16.9	1.6	3.3	1.5	3/4"
	V	28.0	31.0	52.9	3.9	1.6	8.4	1.6	3/4"	1"	13.9	1.6	16.9	1.6	1.4	20.0	3/4"
	D	28.0	31.0	56.8	37.0	2.0	43.0	2.0	3/4"	1"	46.4	1.6	49.1	1.6	1.6	4.7	3/4"
ME036	H	76.5	31.4	25.7	3.9	2.0	8.4	2.0	3/4"	1"	15.6	1.6	18.9	1.6	3.3	3.4	3/4"
	V	31.0	36.0	54.9	3.9	2.0	8.4	2.0	3/4"	1"	15.6	1.6	18.9	1.6	2.0	22.3	3/4"
	D	31.0	36.0	58.6	37.0	2.0	44.3	2.0	3/4"	1"	49.0	1.6	51.8	1.6	1.6	4.7	3/4"
ME048	H	81.5	31.4	25.7	3.9	2.0	8.4	2.0	1"	1"	15.6	1.6	18.9	1.6	3.3	3.4	3/4"
	V	31.0	36.0	58.9	3.9	2.0	8.4	2.0	1"	1"	15.6	1.6	18.9	1.6	2.0	22.3	3/4"
	D	31.0	36.0	62.6	41.0	2.0	48.3	2.0	1"	1"	53.0	1.6	55.7	1.6	1.6	4.7	3/4"
ME060- ME072	H	86.5	31.4	25.7	3.9	2.0	8.4	2.0	1"	1"	15.6	1.6	18.9	1.6	3.3	3.4	3/4"
	V	31.0	36.0	62.9	3.9	2.0	8.4	2.0	1"	1"	15.6	1.6	18.9	1.6	2.0	21.7	3/4"
	D	31.0	36.0	66.6	45.0	2.0	52.3	2.0	1"	1"	56.9	1.6	59.7	1.6	1.6	4.7	3/4"

Notes:

- Commercial water connections are female pipe thread (FPT) fittings
- Residential water connections are swivel connections

Dimensional Data Standard Dimensional Tables

Models:
ME
024-072

Discharge and Return Connections (inch)

Model	Cabinet Config	Discharge Connection Duct Flange Installed					Return Connection Using Return Air Opening			
		Supply Height	Supply Width	O		P	Return Width	Return Height	S	T
				OL (Left Return)	OR (Right Return)					
ME024	H	15.4	12.4	3.8	3.8	2.0	32.1	17.3	4.8	1.0
	V	13.9	13.9	6.8	6.7	5.7	21.2	26.8	2.3	1.0
	D	13.9	13.9	4.9	2.8	5.8	21.2	27.3	2.4	6.0
ME036	H	18.9	17.4	2.9	2.9	1.0	36.0	19.3	2.8	1.0
	V	17.9	17.9	2.0	5.3	6.2	26.1	26.1	2.3	1.0
	D	17.9	17.9	5.4	3.0	6.2	26.1	26.0	2.2	6.0
ME048	H	18.9	17.4	3.0	3.0	1.0	41.0	19.3	2.8	1.0
	V	17.9	17.9	3.0	5.3	6.2	26.1	30.2	2.3	1.0
	D	17.9	17.9	5.4	3.0	6.2	26.1	30.4	2.2	5.7
ME060- ME072	H	18.9	17.4	3.0	3.0	1.0	46.0	19.3	2.8	1.0
	V	17.9	17.9	3.0	5.3	6.2	26.1	34.7	2.3	1.0
	D	17.9	17.9	5.4	3.0	6.2	26.1	36.0	2.2	5.2

Corner Weights (lb)

Model	Left - Front	Right - Front	Left - Back	Right/Back
ME024	68.0	56.0	42.0	42.0
ME036	76.0	63.0	47.0	47.0
ME048	98.0	81.0	60.0	60.0
ME060- ME072	103.0	85.0	63.0	63.0

Hanger Dimensions (inch)

Model	Cabinet Config	Unit Hanger Detail		
		U	V	W
ME024	H	62.1	24.5	20.3
ME036	H	71.1	27.5	23.3
ME048	H	76.1	27.5	23.3
ME060- ME072	H	81.1	27.5	23.3

Heat Controller works continually to improve its products. As a result, the design and specifications of each product at the time of order may be changed without notice and may not be as described herein. Please contact Heat Controller's Customer Service Department at 517-787-2100 for specific information on the current design and specifications. Statements and other information contained herein are not express warranties and do not form the basis of any bargain between the parties, but are merely Heat Controller's opinion or commendation of its products. The latest version of this document is available at www.heatcontroller.com. Engineered and assembled in the USA. © Heat Controller, Inc. All Rights Reserved 2024

Dimensional Data Standard Dimensional Tables

Models:
ME
024-072

Cabinet Dimensions (cm)

Model	Cabinet Config	Depth/Length	Width	Height
		A	B	C
ME024	H	158.0	56.9	49.0
	V	65.0	56.9	123.2
	D	65.0	56.9	133.1
ME036	H	180.8	64.5	54.1
	V	77.7	64.5	128.3
	D	77.7	64.5	137.8
ME048	H	193.5	64.5	54.1
	V	77.7	64.5	138.4
	D	77.7	64.5	148.0
ME060- ME072	H	206.2	64.5	54.1
	V	77.7	64.5	148.6
	D	77.7	64.5	158.1

Electrical Knockouts (cm)

Model	Cabinet Config	H	Low Voltage	High Voltage	G
			J KO 1/2"	K KO 3/4"	
ME024	H	10.4	9.1	21.8	3.2
	V	10.4	9.1	21.8	3.2
	D	95.0	102.7	121.8	3.2
ME036	H	10.4	9.1	21.8	3.2
	V	10.4	9.1	21.8	3.2
	D	95.0	102.3	127.0	3.2
ME048	H	10.4	9.1	21.8	3.2
	V	10.4	9.1	21.8	3.2
	D	104.9	122.9	137.2	3.2
ME060- ME072	H	10.4	9.1	21.8	3.2
	V	10.4	9.1	21.8	3.2
	D	115.3	122.9	147.4	3.2

Shipping Dimensions and Water Connections (cm)

Model	Cabinet Config	Shipping Dimensions			Water Connections										Condensate Drain Pan		
		Depth/Length	Width	Height	Water In		Water Out		Water In/Out		HWG In		HWG Out		AA	BB	Condensate Drain Pan Fitting (MPT)
		A	B	C	D	E	F	E	Com ¹	Res ²	DD	EE	FF	EE			
ME024	H	171.5	72.1	60.1	9.9	4.3	21.3	4.3	3/4"	1"	35.3	4.1	42.9	4.1	8.5	3.8	3/4"
	V	71.1	78.7	134.3	9.9	4.1	21.3	4.1	3/4"	1"	35.3	4.1	42.9	4.1	3.6	50.7	3/4"
	D	71.1	78.7	144.3	94.0	5.1	109.3	5.1	3/4"	1"	117.9	4.0	124.8	4.1	4.1	11.9	3/4"
ME036	H	194.3	79.7	65.2	9.9	5.0	21.3	5.0	3/4"	1"	39.6	4.1	48.0	4.1	8.3	8.6	3/4"
	V	78.7	91.4	139.4	9.9	5.0	21.3	5.0	3/4"	1"	39.6	4.1	48.0	4.1	5.0	56.6	3/4"
	D	78.7	91.4	148.9	94.0	5.1	112.4	5.1	3/4"	1"	124.5	4.1	131.4	4.1	4.1	11.9	3/4"
ME048	H	207.0	79.7	65.2	9.9	5.0	21.3	5.0	1"	1"	39.6	4.1	48.0	4.1	8.3	8.6	3/4"
	V	78.7	91.4	149.6	9.9	5.0	21.3	5.0	1"	1"	39.6	4.1	48.0	4.1	5.0	56.6	3/4"
	D	78.7	91.4	159.1	104.0	5.0	122.7	5.0	1"	1"	134.5	4.1	141.4	4.1	4.1	11.9	3/4"
ME060- ME072	H	219.7	79.7	65.2	9.9	5.0	21.3	5.0	1"	1"	39.6	4.1	48.0	4.1	8.3	8.6	3/4"
	V	78.7	91.4	159.7	9.9	5.0	21.3	5.0	1"	1"	39.6	4.1	48.0	4.1	5.0	55.1	3/4"
	D	78.7	91.4	169.2	114.4	5.0	132.8	5.0	1"	1"	144.6	4.1	151.6	4.1	4.1	11.9	3/4"

Notes:

- Commercial water connections are female pipe thread (FPT) fittings
- Residential water connections are swivel connections

Dimensional Data Standard Dimensional Tables

Models:
ME
024-072

Discharge and Return Connections (cm)

Model	Cabinet Config	Discharge Connection Duct Flange Installed					Return Connection Using Return Air Opening			
		Supply Height	Supply Width	O		P	Return Width	Return Height	S	T
				OL (Left Return)	OR (Right Return)					
M	N									
ME024	H	39.1	31.5	9.5	9.5	5.0	81.5	43.9	12.2	2.5
	V	35.3	35.3	17.3	17.0	14.5	53.8	68.1	5.8	2.5
	D	35.3	35.3	12.4	7.1	14.7	53.8	69.3	6.1	15.2
ME036	H	48.0	44.2	7.5	7.5	2.5	91.4	49.0	7.1	2.5
	V	45.5	45.5	5.1	13.5	15.7	66.3	66.3	5.8	2.5
	D	45.5	45.5	13.7	7.6	15.7	66.3	66.0	5.6	15.2
ME048	H	48.0	44.2	7.6	7.6	2.5	104.1	49.0	7.1	2.5
	V	45.5	45.5	7.6	13.5	15.7	66.3	76.7	5.8	2.5
	D	45.5	45.5	13.7	7.6	15.7	66.3	77.2	5.6	14.5
ME060- ME072	H	48.0	44.2	7.6	7.6	2.5	116.8	49.0	7.1	2.5
	V	45.5	45.5	7.6	13.5	15.7	66.3	88.1	5.8	2.5
	D	45.5	45.5	13.7	7.6	15.7	66.3	91.4	5.6	13.2

Corner Weights (kg)

Model	Left - Front	Right - Front	Left - Back	Right/Back
ME024	30.8	25.4	19.1	19.1
ME036	34.5	28.6	21.3	21.3
ME048	44.5	36.7	27.2	27.2
ME060- ME072	46.7	38.6	28.6	28.6

Hanger Dimensions (cm)

Model	Cabinet Config	Unit Hanger Detail		
		U	V	W
ME024	H	157.7	62.2	51.4
ME036	H	180.6	69.9	59.2
ME048	H	193.3	69.9	59.2
ME060- ME072	H	206.0	69.9	59.2

Heat Controller works continually to improve its products. As a result, the design and specifications of each product at the time of order may be changed without notice and may not be as described herein. Please contact Heat Controller's Customer Service Department at 517-787-2100 for specific information on the current design and specifications. Statements and other information contained herein are not express warranties and do not form the basis of any bargain between the parties, but are merely Heat Controller's opinion or commendation of its products. The latest version of this document is available at www.heatcontroller.com. Engineered and assembled in the USA. © Heat Controller, Inc. All Rights Reserved 2024

Dimensional Data Horizontal

Models:
ME
024-072

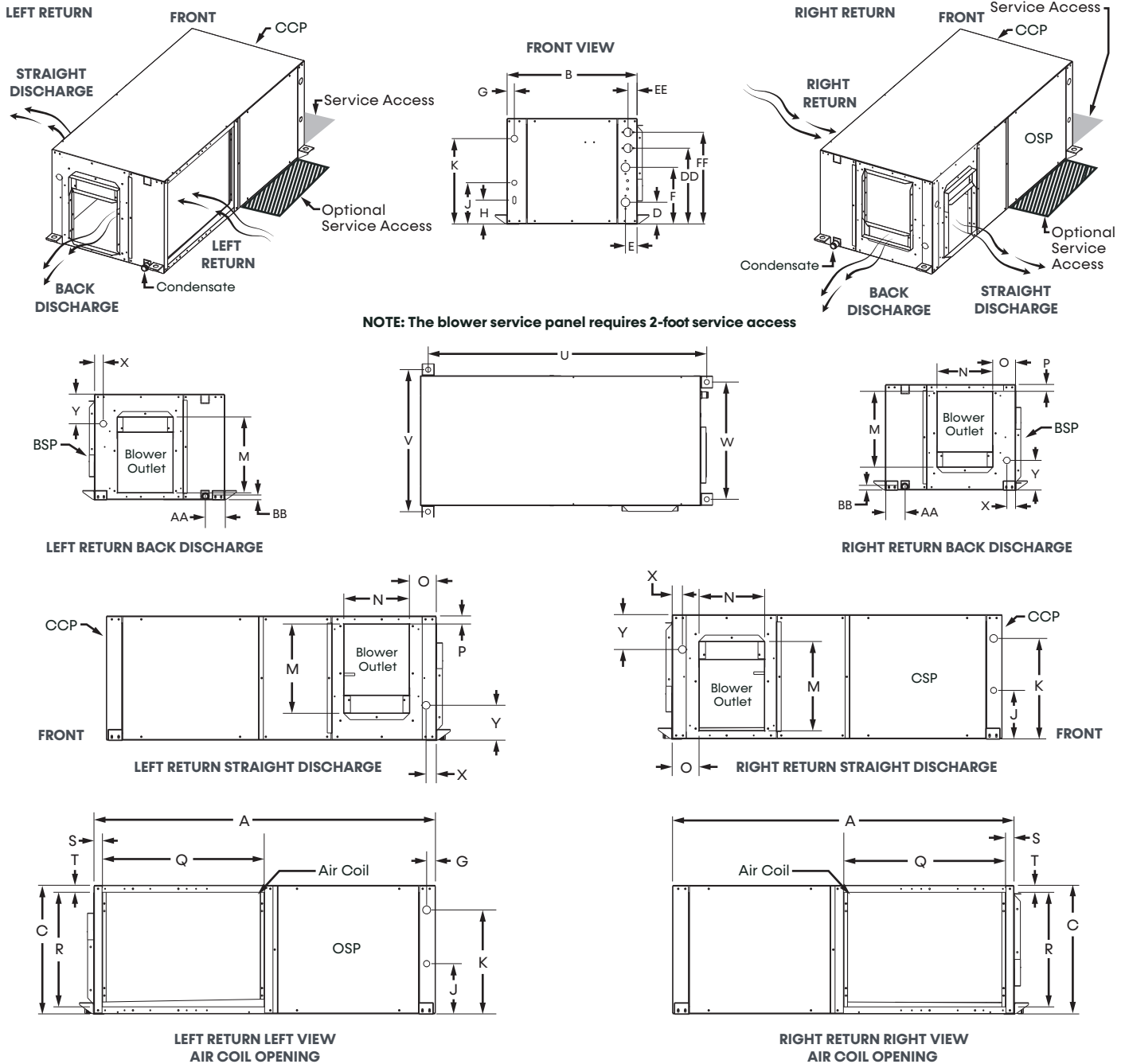

NOTES

1. While clear access to all removable panels is not required, installer should take care to comply with all building codes and allow adequate clearance for future field service.
2. Units come standard with air filter racks, which are suitable for duct connection.
3. Discharge flange and hanger brackets are factory installed.
4. Condensate connection is 3/4-inch MPT.
5. Blower service panel requires 2-foot service access.
6. Blower service access is through back panel on straight discharge units or through panel opposite air coil on back discharge units.
7. Water connections for optional hot water generator are 1-inch swivels.
8. OSP are removable panels that provide additional access to the units interior. Clear access to OSP panels is not required and they are not to be used in place of the mandatory CCP and BSP panels.

LEGEND

CCP = CONTROL/COMPRESSOR ACCESS
BSP = BLOWER SERVICE PANEL
OSP = OPTIONAL SERVICE PANEL (NOT REQUIRED)

Dimensional Data Horizontal Service Access

Models:
ME
024-072

LEFT RETURN BACK DISCHARGE

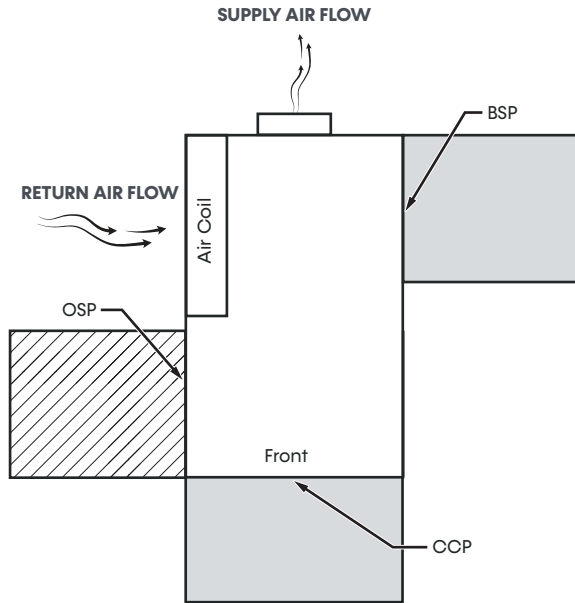

RIGHT RETURN BACK DISCHARGE

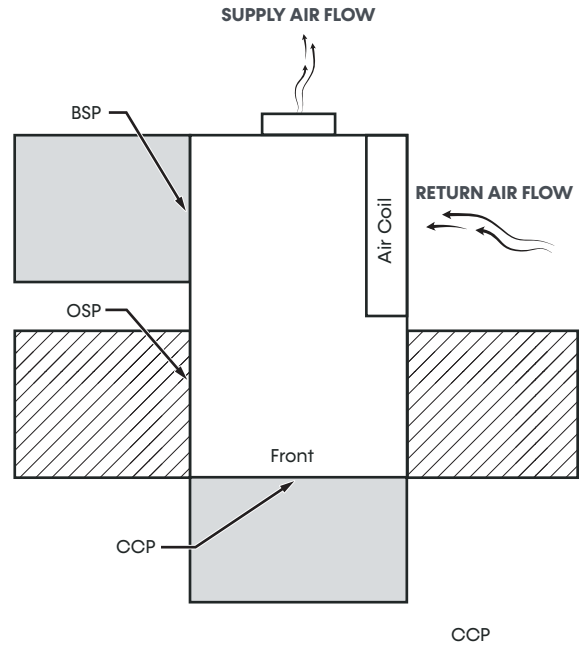

LEFT RETURN STRAIGHT DISCHARGE

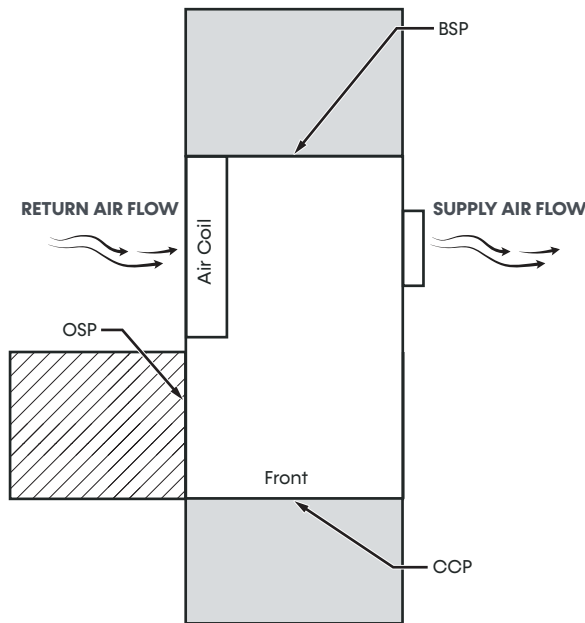

RIGHT RETURN STRAIGHT DISCHARGE

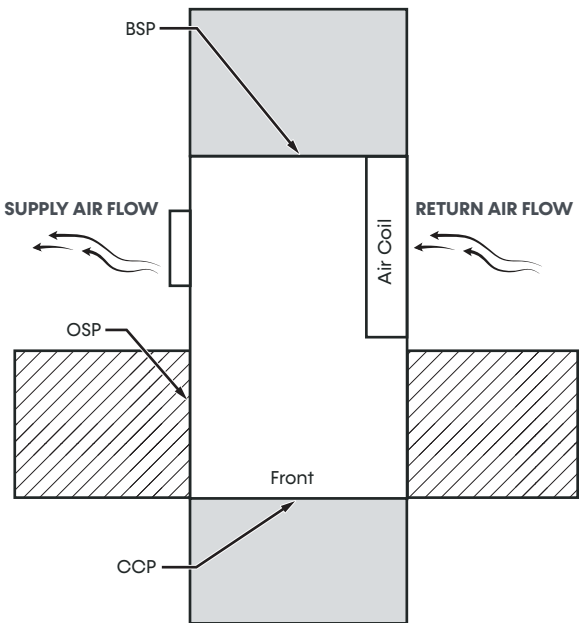

NOTES

1. While clear access to all removable panels is not required, installer should take care to comply with all building codes and allow adequate clearance for future field service.
2. CCP and BSP requires 2-feet of service access.
3. Blower service access is through back panel on straight discharge units or through panel opposite air coil on back discharge units.
4. OSP are removable panels that provide additional access to the units interior. Clear access to OSP panels is not required and they are not to be used in place of the mandatory CCP and BSP panels.

 = Mandatory Service Access 2-foot (61 cm)

 = Optional Service Access 2-foot (61 cm)

LEGEND

CCP = CONTROL/COMPRESSOR ACCESS
BSP = BLOWER SERVICE PANEL
OSP = OPTIONAL SERVICE PANEL (NOT REQUIRED)

Dimensional Data Vertical Upflow

Models:
ME
024-072

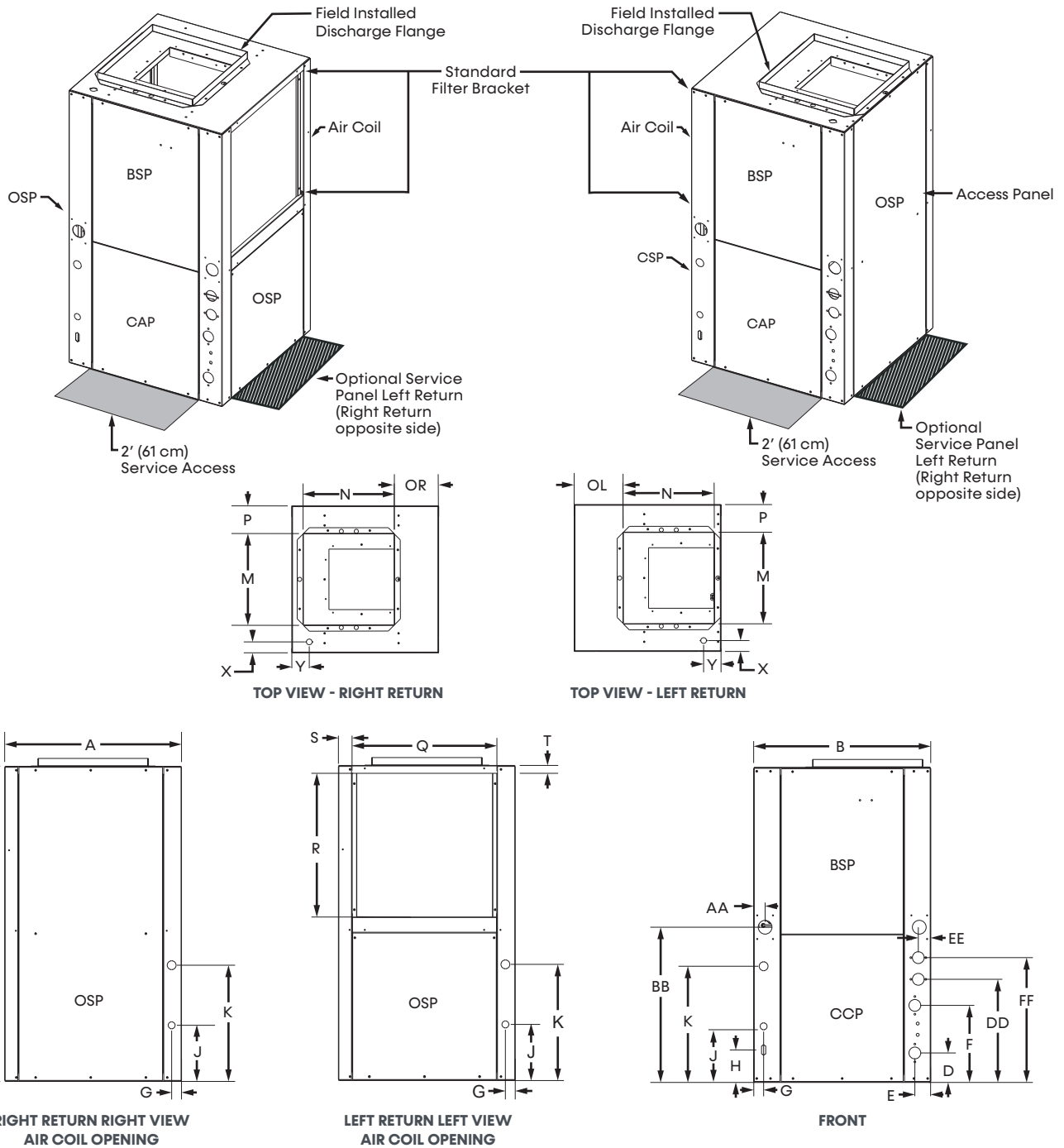

NOTES

1. While clear access to all removable panels is not required, installer should take care to comply with all building codes and allow adequate clearance for future field service.
2. Front and Side access is preferred for service access. However, all components may be serviced from the front access panel if side access is not available.
3. Discharge flange is field installed.
4. Condensate connection is 3/4-inch MPT.
5. Water connections for optional hot water generator are 1-inch swivels.
6. Units come standard with air filter racks, which are suitable for duct connections.

LEGEND

CCP = CONTROL/COMPRESSOR ACCESS
BSP = BLOWER SERVICE PANEL
OSP = OPTIONAL SERVICE PANEL (NOT REQUIRED)

Dimensional Data Vertical Downflow

Models:
ME
024-072

LEFT DOWNFLOW

RIGHT DOWNFLOW

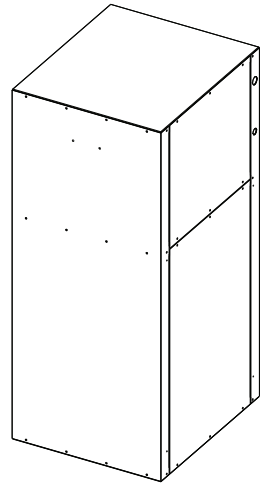
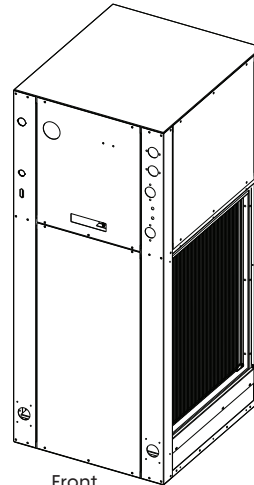
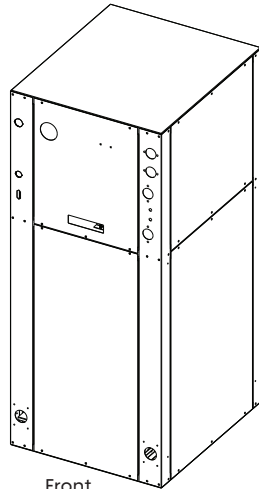
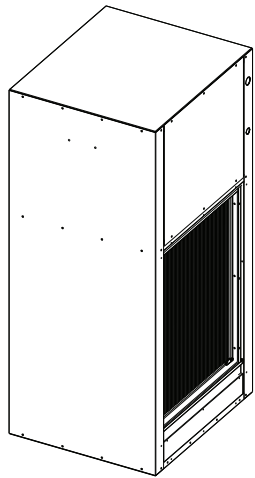

ISO BACK

Front
↙

Front
↙

ISO BACK

LEFT

BOTTOM

BOTTOM

RIGHT

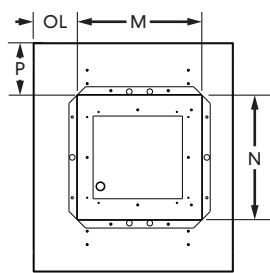
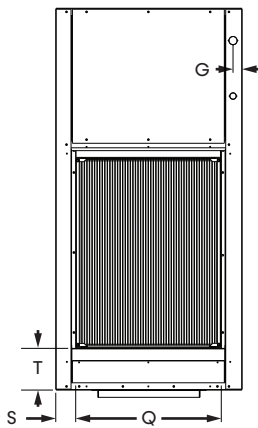

Front
↑

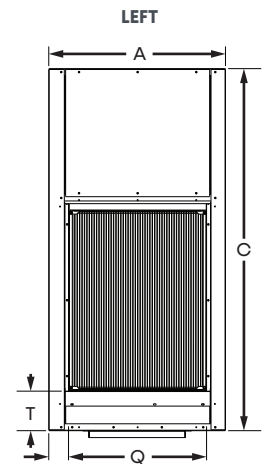
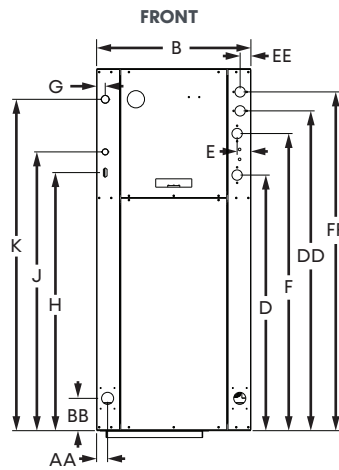
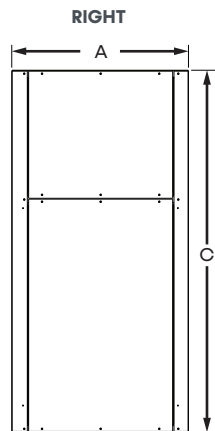
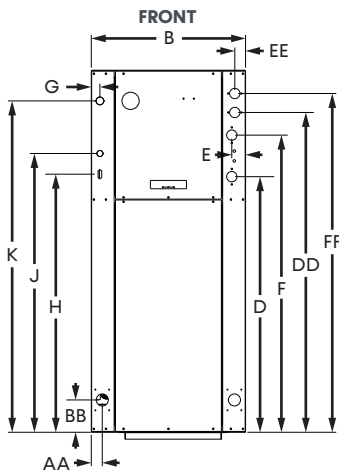
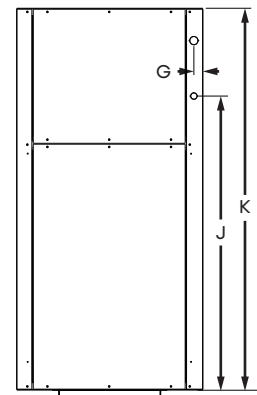
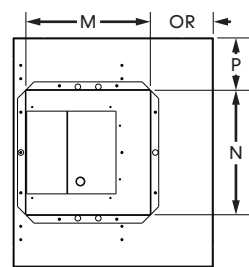

Heat Controller works continually to improve its products. As a result, the design and specifications of each product at the time of order may be changed without notice and may not be as described herein. Please contact Heat Controller's Customer Service Department at 517-787-2100 for specific information on the current design and specifications. Statements and other information contained herein are not express warranties and do not form the basis of any bargain between the parties, but are merely Heat Controller's opinion or commendation of its products. The latest version of this document is available at www.heatcontroller.com. Engineered and assembled in the USA. © Heat Controller, Inc. All Rights Reserved 2024

Dimensional Data Vertical Service Access

Models:
ME
024-072

LEFT RETURN

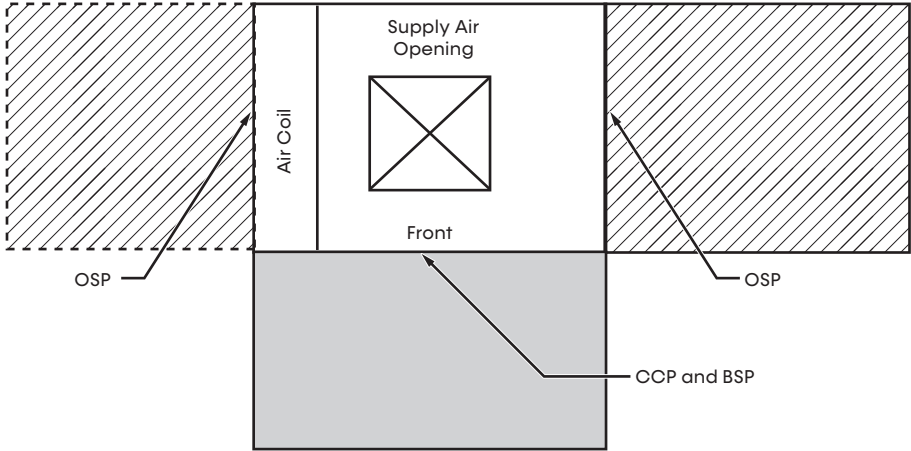

RIGHT RETURN

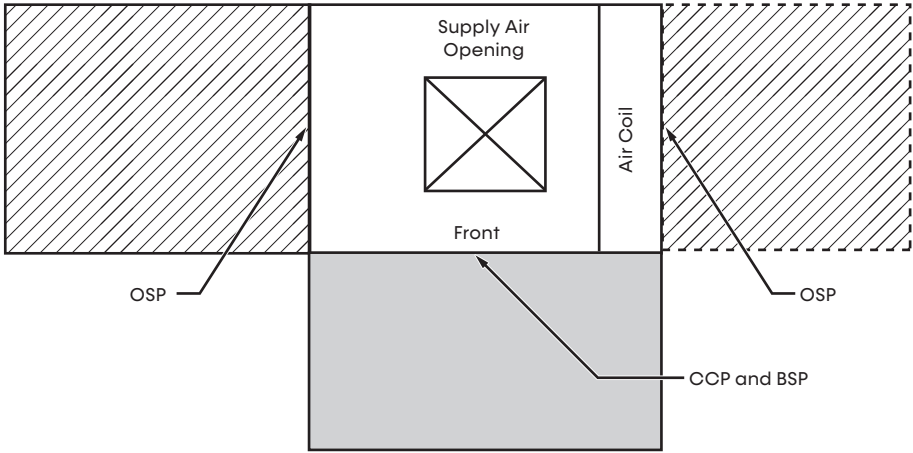

NOTES

1. While clear access to all removable panels is not required, installer should take care to comply with all building codes and allow adequate clearance for future field service.
2. Front and side access is preferred for service access. However, all components may be serviced from the front access panel if side access is not available.
3. OSP are removable panels that provide additional access to the units interior. Clear access to OSP panels is not required and they are not to be used in place of the mandatory CCP and BSP panels.
4. Top supply air is shown, the same clearances apply to bottom supply air units.

 = Mandatory Service Access 2 feet (61 cm)

 = Optional Service Access 2 feet (61 cm)

LEGEND

CCP = CONTROL/COMPRESSOR ACCESS
BSP = BLOWER SERVICE PANEL
OSP = OPTIONAL SERVICE PANEL (NOT REQUIRED)

MINIMUM INSTALLATION AREA

Minimum area where a blower-equipped unit must be installed, and mechanical/natural ventilation is not required

Model	Charge (oz)	Configuration	Minimum Installation Area ft ² (m ²) [A _{min}]			
			Floor	Window	Wall	Ceiling
ME060	102	Vertical	351 (32.61)	195 (18.12)	112 (10.41)	92 (8.55)
		Horizontal	351 (32.61)	209 (19.42)	116 (10.78)	95 (8.83)
ME072	109	Vertical	375 (34.84)	209 (19.42)	120 (11.15)	99 (9.20)
		Horizontal	375 (34.84)	223 (20.72)	124 (11.52)	102 (9.48)

A _{min}	=	Minimum area where unit is installed where unit has incorporated airflow
h _{inst} (floor)	=	0.0 ft (0.0 m)
h _{inst} (window)	=	3.3 ft (1.0 m)
h _{inst} (wall)	=	5.9 ft (1.8 m)
h _{inst} (ceiling)	=	7.2 ft (2.2 m)

Minimum area and CFM requirements for the conditioned space

Model	Charge (oz)	Minimum CFM [Q _{min}]	
		TA _{min} ft ² (m ²)	Q _{min} (ft ³ /min)
ME060	102	5.2 (0.48)	173 (293.07)
ME072	109	5.6 (0.52)	184 (313.19)

TA _{min}	=	Minimum conditioned area for venting leaked refrigerant
Q _{min}	=	Minimum ventilation flow rate for conditioned space if space is less than TA _{min}

Minimum area of opening for natural ventilation

Model	Charge (oz)	Anv _{min} in ² (cm ²)
ME060	102	135.65 (344.55)
ME072	109	140.23 (356.18)

Anv _{min}	=	Minimum natural ventilation area opening
--------------------	---	--

When the openings for connected rooms or natural ventilation are required, the following conditions shall be applied:

- The area of any openings above 11.8 inches (300 mm) from the floor shall not be considered in determining compliance with Anv_{min}.
- At least 50% of the required opening area Anv_{min} shall be below 7.8 inches (200 mm) from the floor.
- The bottom of the lowest openings shall not be higher than the point of release when the unit is installed and not more than 3.9 inches (100 mm) from the floor.
- Openings are permanent openings which cannot be closed.
 - For openings extending to the floor, the height shall not be less than 0.78 inch (20 mm) above the surface of the floor covering.
- A second higher opening shall be provided. The total size of the second opening shall not be less than 50% of minimum opening area for Anv_{min} and shall be at least 3.3 ft (1.5 m) above the floor.

ACCESSORIES AND OPTIONS

Hot Water Generator

An optional insulated heat reclaiming desuperheater coil of vented double-wall copper construction suitable for potable water shall be provided. The coil, hot water circulating pump, and associated controls shall be factory mounted inside the unit cabinet. Sensors mounted on the compressor discharge line and the potable water inlet shall transmit temperatures to the unit microprocessor where internal logic will determine when hot water generation is feasible. The microprocessor shall cycle the pump periodically during unit operation to sample the DHW tank temperature. The microprocessor shall include multiple temperature set points to select from for hot water generation control.

Cupronickel Heat Exchanger

An optional corrosion resistant CuNi coaxial heat exchanger shall be factory installed in lieu of standard copper construction.

Communicating Thermostat (field installed)

An electronic communicating LCD thermostat shall be provided. The thermostat shall offer three stages of heating and two stages of cooling with precise temperature control and have a four-wire connection to the unit. The thermostat shall be capable of manual or automatic change-over operation and shall operate in standard or programmable mode. An integrated humidity control feature shall be included to control a humidifier and/or a dehumidifier. The thermostat shall include a utility demand reduction feature to be initiated by an independent time program or an external input.

The thermostat shall have a comprehensive installation setup menu to include configuration of the unit CFM for each mode of operation and configuration of the water flow rate through the unit, including variation of the water flow rate based on the stage of unit operation.

The thermostat shall display system faults with probable cause and troubleshooting guidance. Comprehensive service diagnostics menus shall display, system inputs, system outputs, configuration settings, Geo source inlet and outlet temperatures, compressor discharge line temperature, liquid line temperature, leaving air temperature, and entering potable water temperature (on units equipped with a Hot Water Generator). The thermostat shall allow for immediate manual control of all DXM2.6 outputs at the thermostat for rapid troubleshooting.

Auxiliary Heater (field installed)

An external, field-installed electric heater shall provide supplemental and/or emergency heating capability when used with the three stage heating thermostat.

Revision History

Models:
ME
024-072

Date	Section	Description
03/25/26	All	Updated DXM2.5 to DXM2.6 throughout
01/16/26	Model Nomenclature	Updated
	Performance Data	Added performance data for all sizes for units without Variable Water Flow
	CV EC Motor Limits	Removed note concerning maximum allowable altitude
	Physical Data	Updated the Unit Maximum Working Water Pressures table
	Dimensional Tables	Corrected the condensate drain pan fitting type to MPT
12/12/25	Performance Data	Updated
	CV EC Motor Limits	Updated
	Electrical Data	Added new data for additional configurations
06/04/25	Dimensional Data	Updated Hanger Dimensions for all sizes
04/25/25	Electrical data	Updated CV EC FLA for sizes 036-048
		Updated Total Unit FLA for sizes 036-048
		Updated Minimum Circuit Amp for sizes 036-048
02/26/25	Electrical Data: CV EC Blower Motor	Updated Voltage Code for sizes 060 and 072
	Blower Performance Data	Added Aux/Emergency Mode column

Due to ongoing product improvements, specifications, and dimensions are subject to change and correction without notice or incurring obligations. Determining the application and suitability for use of any product is the responsibility of the installer. Additionally, the installer is responsible for verifying dimensional data on the actual product prior to beginning any installation preparations.

Incentive and rebate programs have precise requirements as to product performance and certification. All products meet applicable regulations in effect on date of manufacture; however, certifications are not necessarily granted for the life of a product. Therefore, it is the responsibility of the applicant to determine whether a specific model qualifies for these incentive/rebate programs.



1900 Wellworth Ave. | Jackson, MI 49203
Phone: 517-787-2100
www.heatcontroller.com



Heat Controller works continually to improve its products. As a result, the design and specifications of each product at the time of order may be changed without notice and may not be as described herein. Please contact Heat Controller's Customer Service Department at 517-787-2100 for specific information on the current design and specifications. Statements and other information contained herein are not express warranties and do not form the basis of any bargain between the parties, but are merely Heat Controller's opinion or commendation of its products. The latest version of this document is available at www.heatcontroller.com. Engineered and assembled in the USA. © Heat Controller, Inc. All Rights Reserved 2024