

---

*Comfort-Cire*® **Century**®  
SE Series

---

**Heat Pump Packaged Unit**  
RHP\*\*S1A

Instruction Manual





RECOGNIZE THIS SYMBOL AS AN INDICATION OF IMPORTANT SAFETY INFORMATION

**WARNING**

These instructions are intended as an aid to qualified, licensed service personnel for proper installation, adjustment and operation of this unit. Read these instructions thoroughly before attempting installation or operation. Failure to follow these instructions may result in improper installation, adjustment, service or maintenance possibly resulting in fire, electrical shock, property damage, personal injury or death.

# CONTENTS

<b>1 SAFETY</b>	
• 1.1 Inspection.....	02
• 1.2 Limitations.....	02
<b>2 INSTALLATION</b>	
• 2.1 Pre-Installation.....	02
• 2.2 Rigging and Handling.....	02
• 2.3 Unit Dimensions.....	03
• 2.4 Roof Curb.....	08
• 2.5 Location Restrictions.....	09
<b>3 DUCTWORK.....</b>	<b>10</b>
<b>4 CONDENSATE DRAIN CONNECTION</b>	
• 4.1 Install Drain Pipe.....	11
• 4.2 Removal and Cleaning The Drain Pan.....	11
<b>5 FILTERS.....</b>	<b>11</b>
<b>6 ELECTRICAL WIRING</b>	
• 6.1 Power Wiring.....	11
• 6.2 Grounding.....	12
• 6.3 Control Wiring.....	13
<b>7 AIRFLOW PERFORMANCE</b>	
• 7.1 Airflow Performance Data.....	14
<b>8 SYSTEM OPERATION</b>	
• 8.1 Compressor Crankcase Heater.....	15
• 8.2 Protection.....	15
• 8.3 Defrost Mode.....	15
• 8.4 Thermostat Signals.....	16
<b>9 OPERATION CHECK-UP.....</b>	<b>16</b>
<b>10 TROUBLE SHOOTING.....</b>	<b>16</b>

This document is customer property and is to remain with this unit.

These instructions do not cover all the different variations of systems nor does it provide for every possible contingency to be met in connection with installation.

All phases of this installation must comply with NATION, STATE AND LOCAL CODES. If additional information is required please contact your local distributor.

## 1 SAFETY

When you see the symbols below on labels or in the manual, be alert to the potential or immediate hazards of personal injury, property and/or product damage. It is the owner's or installer's responsibility to comply with all safety instructions and information accompanying these symbols.



**WARNING:** This is a safety alert symbol indicating a potential hazardous situation, which could result in personal injury, property and/or product damage or death.



**CAUTION:** This is a safety alert symbol indicating a potential hazardous situation, which could result in moderate personal injury, and/or property and product damage.

### WARNING

These instructions are intended as an aid to qualified, licensed service personnel for proper installation, adjustment and operation of this unit. Read these instructions thoroughly before attempting installation or operation.

Failure to follow these instructions may result in improper installation, adjustment, service or maintenance possibly resulting in fire, electrical shock, property damage, personal injury or death.

### WARNING

The manufacturer's warranty does not cover any damage or defect to the heat pump caused by the attachment or use of any components, accessories or devices (other than those authorized by the manufacturer) into, onto or in conjunction with the heat pump. You should be aware that the use of unauthorized components, accessories or devices may adversely affect the operation of the heat pump and may also endanger life and property. The manufacturer disclaims any responsibility for such loss or injury resulting from the use of such unauthorized components, accessories or devices.

### WARNING

Disconnect all power to the unit before starting maintenance. Failure to do so can result in severe electrical shock or death.

### WARNING

Do not, under any circumstances, connect return ductwork to any other heat producing device such as a fireplace insert, stove, etc. Unauthorized use of such devices may result in fire, carbon monoxide poisoning, explosion, property damage, severe personal injury or death.

### WARNING

The unit must be permanently grounded. A grounding lug is provided. Failure to ground this unit can result in fire or electrical shock causing property damage, severe personal injury or death.

### WARNING

Only electric heater kits supplied by this manufacturer as described in this publication have been designed, tested, and evaluated by a nationally recognized safety testing agency for use with this unit. Use of any other manufactured electric heaters installed within this unit may cause hazardous conditions resulting in property damage, fire, body injury or death.

### WARNING

Proposition 65: This appliance contains fiberglass insulation. Respirable particles of fiberglass are known to the state of California to cause cancer.

### CAUTION

Only use this unit in well-ventilated spaces and ensure that there are no obstructions that could impede the airflow into and out of the unit.

Do not use this unit in the following locations:

- Locations with mineral oil.
- Locations with saline atmospheres, such as seaside locations.
- Locations with sulphurous atmospheres, such as near natural hot springs.
- Where high voltage electricity is present, such as in certain industrial locations.
- On vehicles or vessels, such as trucks or ferry boats.
- Where exposure to oily or very humid air may occur, such as kitchens.
- In proximity to sources of electromagnetic radiation, such as high-frequency transmitters or other high strength radiation devices.

### 1.1 Inspection

As soon as unit is received, it should be inspected and noted for possible shipping damage during transportation. It is shipping responsibility to cover the cost of shipping damage. Manufacturer or distributor will not accept the claims from dealer for any transportation damage.

### 1.2 Limitations

Refer to Fig. 2-3, 2-4,2-6,2-7 for unit physical data and to Table 6-1,6-2 for electrical data. If components are to be added to a unit they must meet local codes, they are to be installed at the dealer's and / or the customer's expense. Size of unit for proposed installation should be based on heat loss / heat gain calculations made in accordance with industry recognized procedures identified by the Air Conditioning Contractors of America.

## 2 INSTALLATION

### 2.1 Pre-Installation

Before installation, carefully check the following:

1. Unit should be installed in accordance with national and local safety codes, including but not limit to ANSI/NFPA No. 70 or Canadian Electrical Code Part 1, C22.1, local plumbing and wastewater codes and any other applicable codes.
2. For rooftop installation, be sure the structure has enough strength to support the weight of unit. Unit should be installed on roof curb and leveled.
3. For ground level installation, a level slab should be used.
4. Condenser airflow should not be restricted.
5. On applications when a roof curb is used, the unit must be positioned on the curb so the front of the unit is tight against the curb.

### 2.2 Rigging and Handing

Exercise care when moving the unit. Do not remove any packaging until the unit is near the place of installation. Rig the unit by attaching chain or cable slings to the lifting holes provided in the base rails. Spreader bars, whose length exceeds the largest dimension across the top of the unit, MUST be used across the top of the unit.

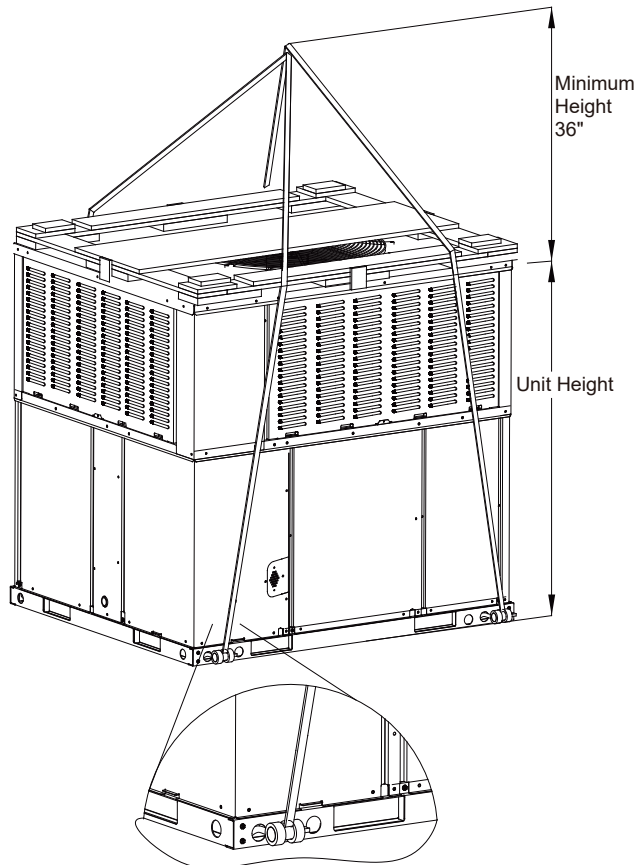

Fig. 2-1 Hoisting Diagram

\* The above figure for reference purpose only.

**⚠ CAUTION**

Before lifting, make sure the unit weight is distributed equally on the rigging cables so it will lift evenly.

Units may be moved or lifted with a forklift. Slotted openings in the base rails are provided for this purpose.

**⚠ CAUTION**

All panels must be secured in place when the unit is lifted.  
The condenser coils should be protected from rigging cable damage with plywood or other suitable material.

**⚠ WARNING**

Check the electric wire, water and gas pipeline layout inside the wall, floor and ceiling before installation. Do not implement drilling unless confirm safety with the user, especially for the hidden power wire. An electroprobe can be used to test whether a wire is passing by at the drilling location, to prevent physical injury or death caused by insulation broken cords.

**⚠ WARNING**

Check the power supply before installation. Ensure that the power supply must be reliably grounded following local, state and National Electrical Codes. If not, for example, if the ground wire is detected charged, installation is prohibited before it is rectified. Otherwise, there is a risk of fire and electric shock, causing physical injury or death.

**2.3 Unit Dimensions**

Component Location-24k&36k

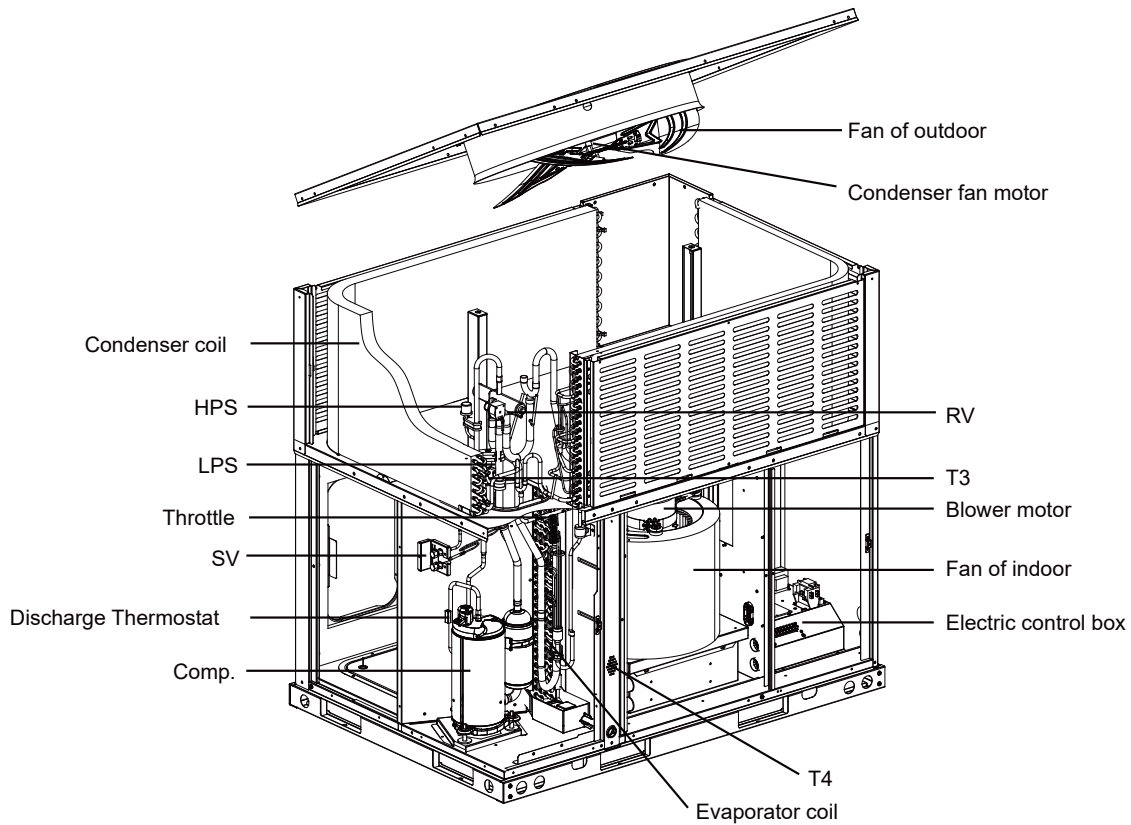

Fig. 2-2 Component Location

\* The above figure for reference purpose only.

Unit Dimensions-24k&36k

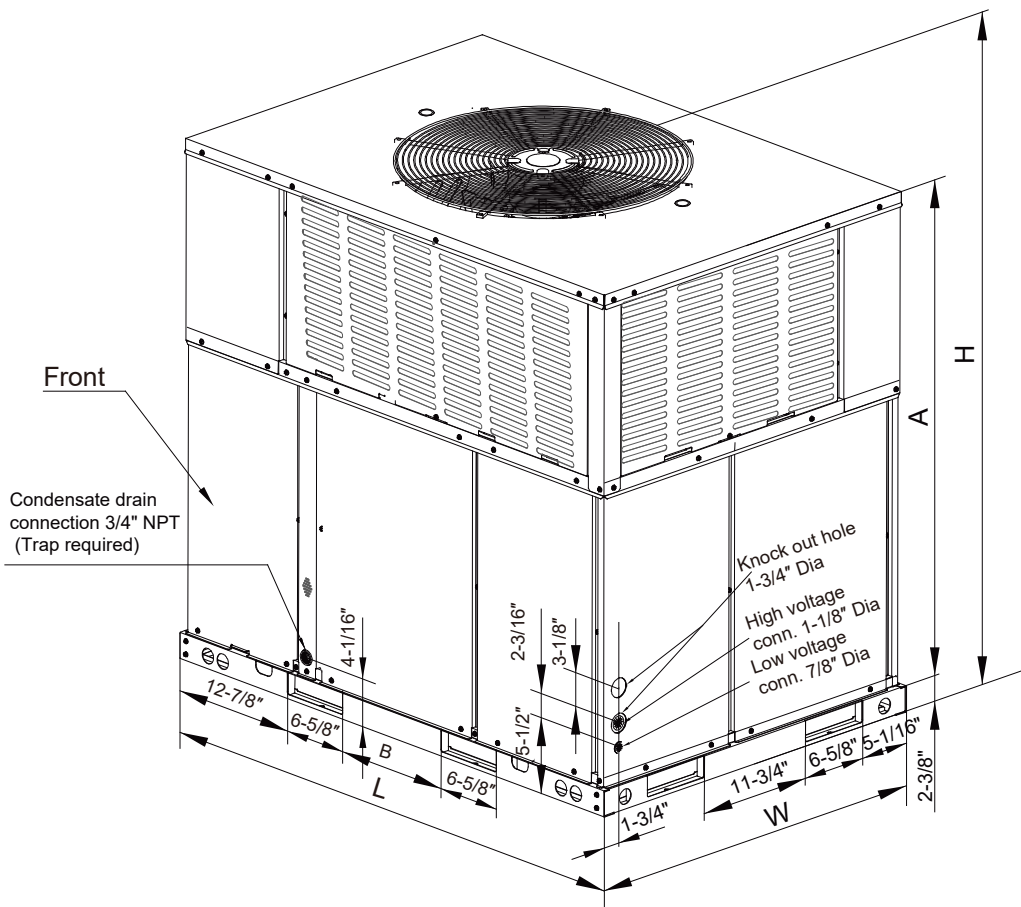

Fig. 2-3 Unit Dimensions

\* The above figure for reference purpose only.

Model size	Dimensions				
Heat Pump	"L" in.[mm]	"W" in.[mm]	"H" in.[mm]	"A" in.[mm]	"B" in.[mm]
24/36	50-11/16 [1287]	35-1/16 [891]	46-13/16 [1190]	44-1/16 [1120]	11-3/4 [298]

Table 2-1 Unit Dimensions

Dimensions Back and Bottom-24K&36K

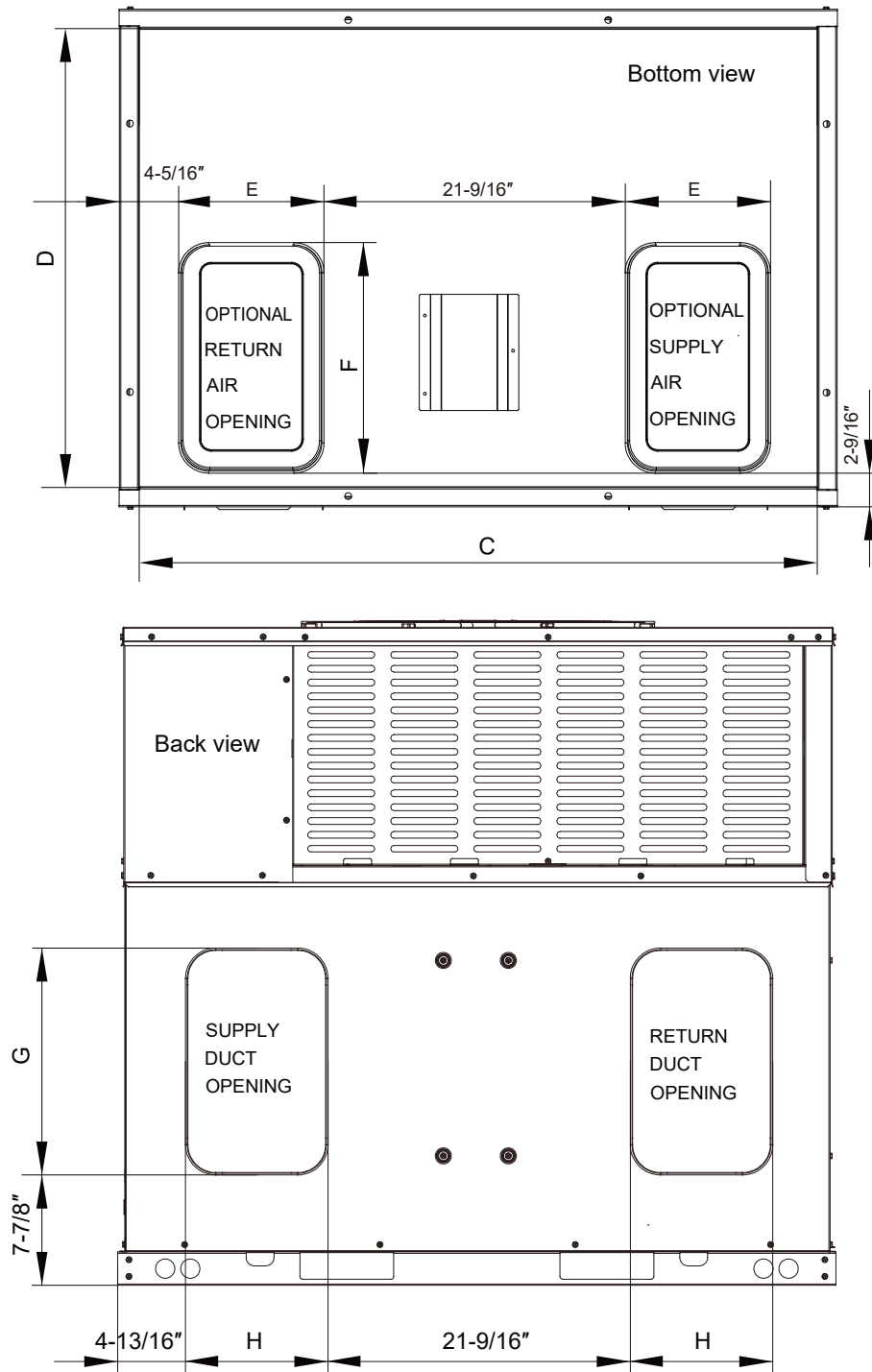

Fig. 2-4 Dimensions Back and Bottom

\* The above figure for reference purpose

Model size	Dimensions					
Heat Pump	"C" in.[mm]	"D" in.[mm]	"E" in.[mm]	"F" in.[mm]	"G" in.[mm]	"H" in
24/36	47-13/16 [1215]	32-1/4 [820]	9-15/16 [252]	15-7/8 [403]	15-3/4 [400]	9-3/4

Table 2-2 Unit Dimensions

Component Location-48K&60K

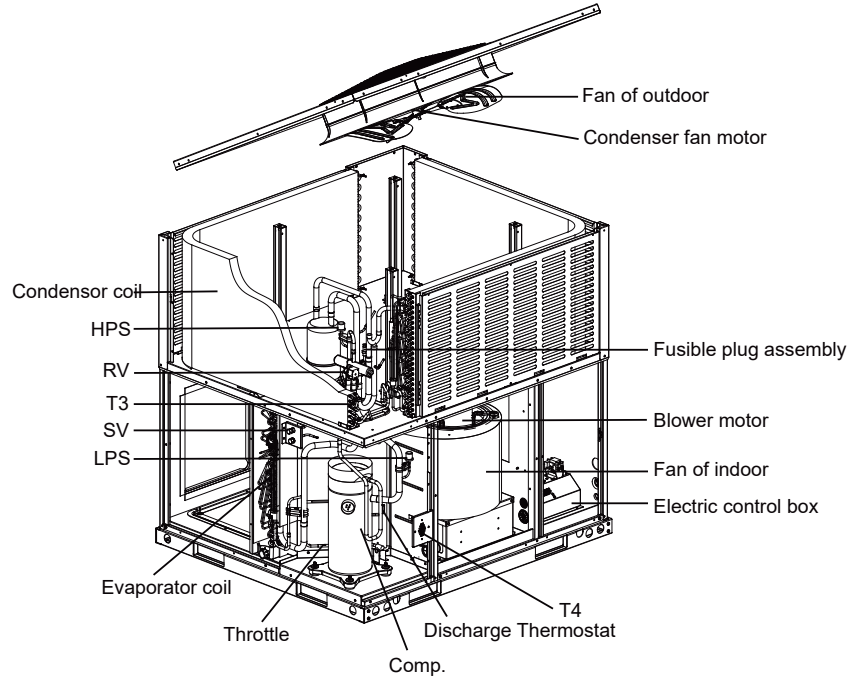

Fig. 2-5 Component Location

\* The above figure for reference purpose only.

Unit Dimensions-48K&60K

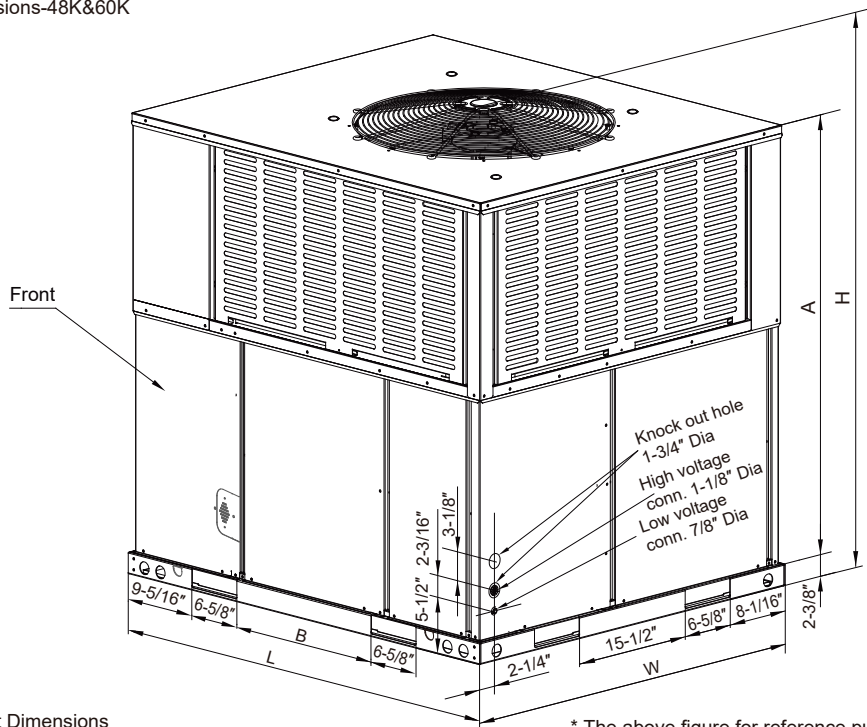

Fig. 2-6 Unit Dimensions

\* The above figure for reference purpose only.

Model size	Dimensions				
Heat Pump	"L" in.[mm]	"W" in.[mm]	"H" in.[mm]	"A" in.[mm]	"B" in.[mm]
48/60	51-9/16 [1310]	44-13/16 [1140]	51-7/16 [1306]	47-5/16 [1202]	19-11/16 [500]

Table 2-3 Unit Dimensions

Dimensions Back and Bottom-48K&60k

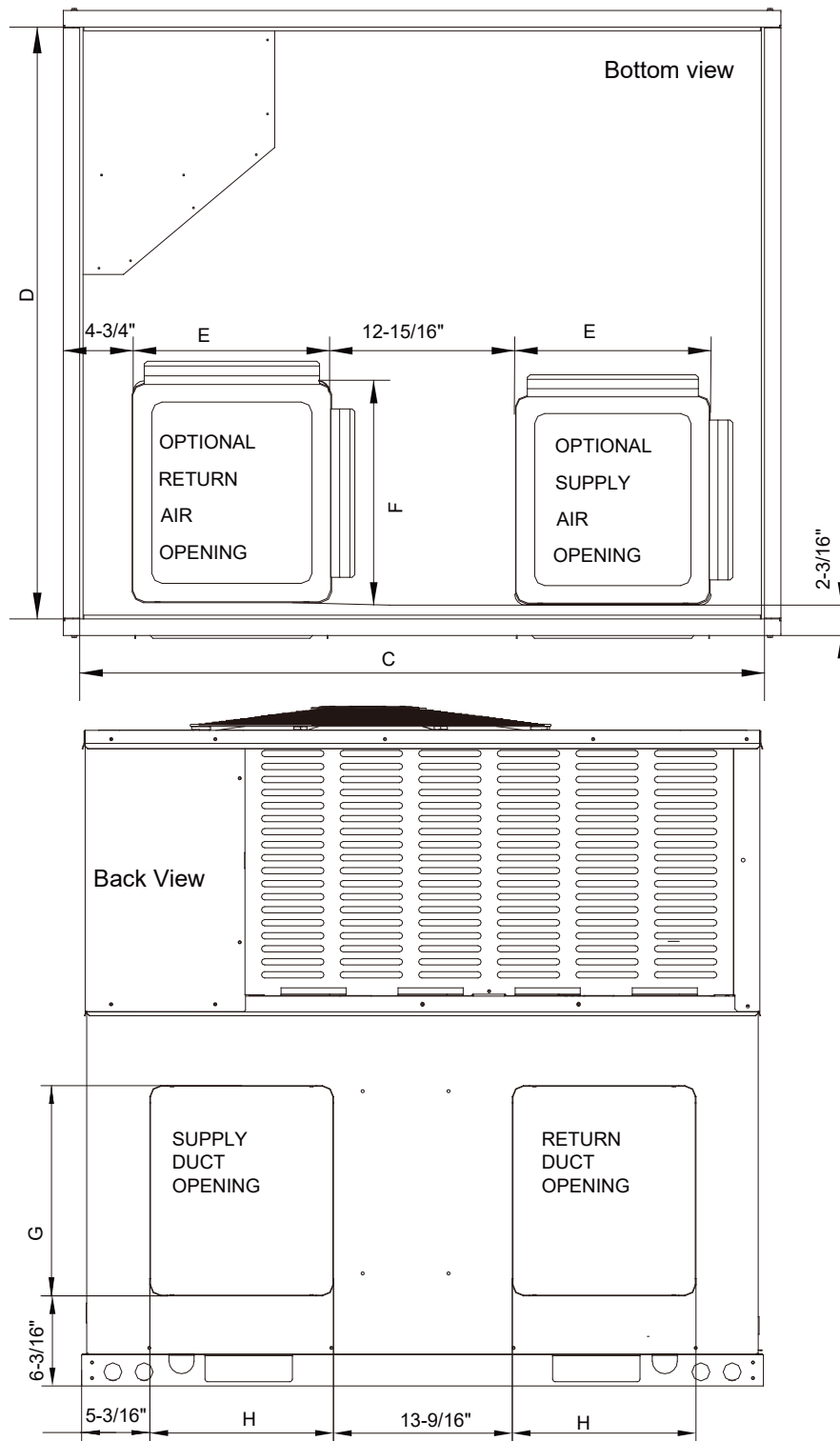

Fig. 2-7 Dimensions Back and Bottom

\* The above figure for reference purpo

Model size	Dimensions					
Heat Pump	"C" in.[mm]	"D" in.[mm]	"E" in.[mm]	"F" in.[mm]	"G" in.[mm]	"H" in.
48/60	49-1/4 [1250]	42-1/2 [1080]	14-1/8 [358]	16-1/8 [409]	15-7/8 [403]	13-7/8

Table 2-4 Unit Dimensions

**NOTE**

For units applied with a roof curb, the minimum clearance may be reduced from 1 inch to 1/2 inch between combustible roof curb material and this supply air duct.

**2.4 Roof Curb**

On applications when a roof curb is used, the unit must be positioned on the curb so the front of the unit is tight against the curb. (See Fig.2-8 ROOF CURB DIMENSIO)

**NOTE**

For units applied with a roof curb, the minimum clearance may be reduced from 1 inch to 1/2 inch between combustible roof curb material and this supply air duct.

Roof Curb Dimension

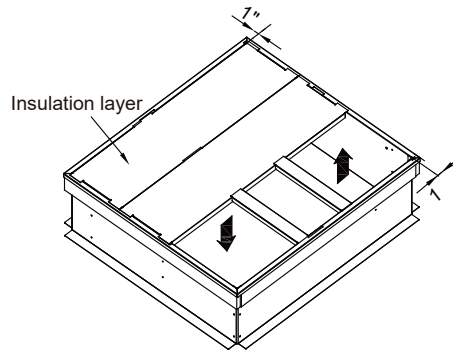

Supply and return air (including duct support rails) shown are typical for bottom duct applications. For location of horizontal duct applications (on back of unit), refer to unit dimension details.

Fig. 2-8

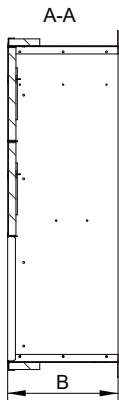

LARGE CURB(48k,60k)

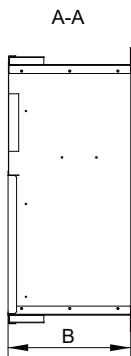

SMALL CURB(24k,36k)

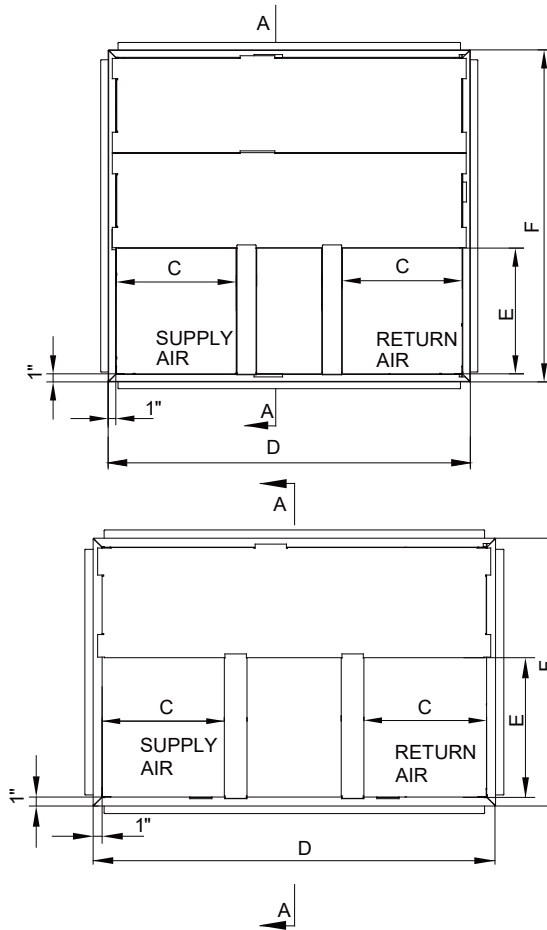

Fig. 2-9 Roof Curb Details

\* The above figure for reference purpose only.

CURB	Dimensions(Inches)				
	"B" in.[mm]	"C" in.[mm]	"D" in.[mm]	"E" in.[mm]	"F" in.[mm]
LARGE	14-1/4 [362]	15-1/4 [387]	46-1/16 [1170]	16 [406]	42-3/16 [1070]
SMALL	14-1/4 [362]	14 [356]	46-1/16 [1170]	16 [406]	30-5/8 [778]

Table 2-5 Unit Dimensions

**NOTE**

All panels must be secured in place when the unit is lifted. The condenser coils should be protected from rigging cable damage with plywood or other suitable material.

**2.5 Location Restrictions**

Ensure the top discharge area is unrestricted for at least 60 inches above the unit.

Do not locate outdoor unit near bedrooms since normal operational sounds may be objectionable.

Position unit to allow adequate space for unobstructed airflow, wiring, refrigerant lines, and serviceability.

Allow a minimum of 12 in. clearance on one side of access panel to a wall and a minimum of 24 in. on the adjacent side of access panel.

Maintain a distance of 24 in. between units.

Position unit where water, snow, or ice from roof or overhang cannot fall directly on unit. (See Fig.2-11 and Fig.2-12.)

**CAUTION:**

**Cold climate considerations (heat pump only)**

**NOTE**

Precautions must be taken for units being installed in areas where snow accumulation and prolonged below-freezing temperatures occur.

- Units should be elevated 3-12 inches above the pad or rooftop, depending on local weather. This additional height will allow drainage of snow and ice melted during defrost cycle prior to its refreezing. Ensure that drain holes in unit base pan are not obstructed, preventing drainage of defrost water (See Fig.2-13).
- If possible, avoid locations that are likely to accumulate snow drifts. If not possible, a snow drift barrier should be installed around the unit to prevent a build-up of snow on the sides of the unit.

Note: Make sure that Condensate Drain side is not higher than the other side (Fig.2-10).

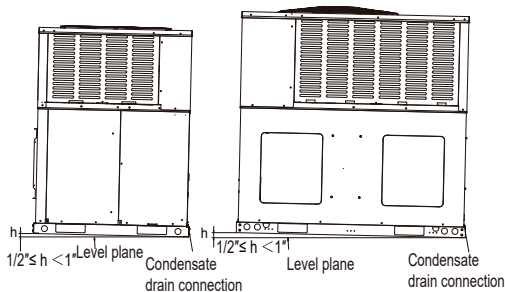

\* The above figure for reference purpose only.

Fig. 2-10 Slab installation

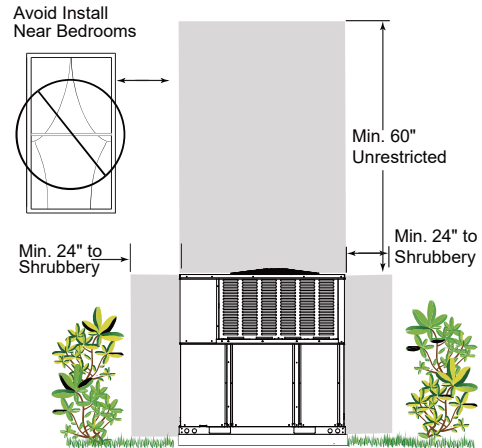

Fig. 2-11

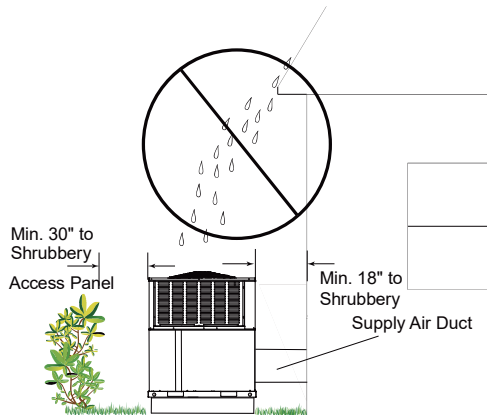

Fig. 2-12

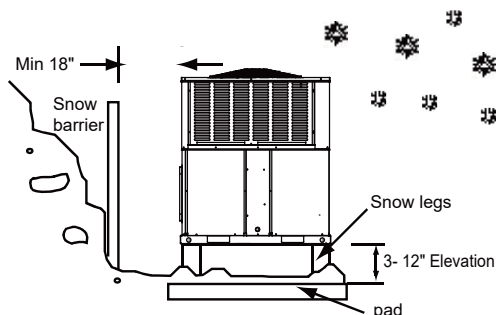

Fig. 2-13

### 3 DUCTWORK

Ductwork should be sized and installed by the installing contractor in accordance with the Manual D from the Air Conditioning Contractors of America, and all national, state and local codes.

**NOTE**

On ductwork exposed to outside air space, use at least 2" of insulation and a vapor barrier. Flexible joint may be used to reduce noise.

A closed return duct system shall be used. This shall not preclude use of economizers or ventilation air intake. Flexible joints may be used in the supply and return duct work to minimize the transmission of noise.

**CAUTION**

When fastening duct work to the side duct flanges on the unit, insert the screws through the duct flanges only. **DO NOT** insert the screws through the casing. Outdoor duct work must be insulated and waterproofed.

**NOTE**

Be sure to note supply and return openings. Refer to Fig. 3-2 for information concerning supply and return air duct openings.

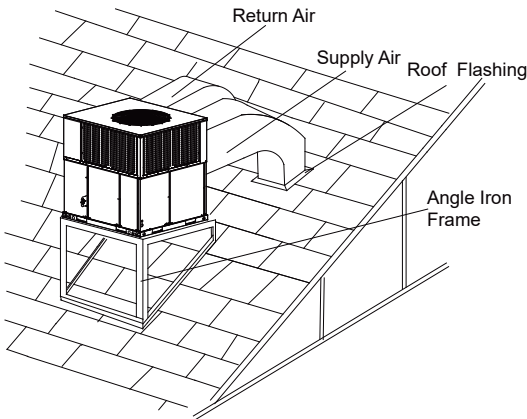

Fig. 3-1 Rooftop Installation—Frame Mounting

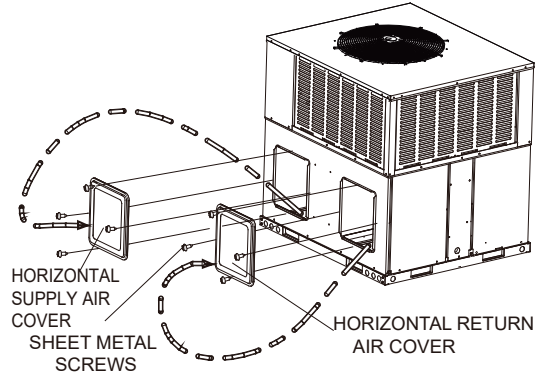

Fig. 3-2

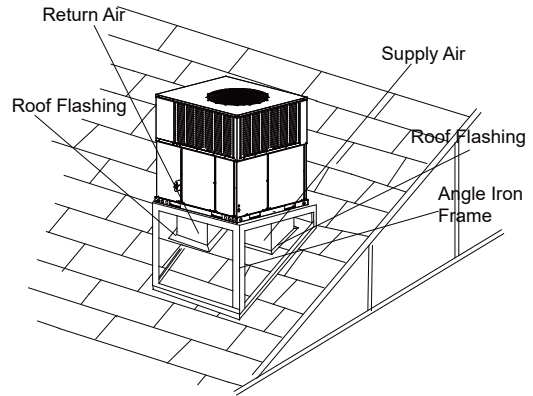

Fig. 3-3 Typical Rooftop Down Airflow Application with Frame

After the unit is installed, there should be no open passages through the supporting structure that would permit flame or hot gases from a fire originating in the space below the supporting structure to travel to the space above that structure.

**NOTE**

A unit with electric heaters with an inlet or outlet duct that penetrates the building structure supporting the unit shall be provided with a mounting base of noncombustible material so designed that, after the unit is installed, there will be no open passages through the supporting structure that would permit flame or hot gases from a fire originating in the space below the supporting structure to travel to the space above that structure. If the unit is intended to be installed on a supporting structure of combustible material, the base shall be so designed that the required clearance will be maintained between the supporting unit mounting base, and shall extend not less than 76 mm (3 in.) below the upper surface of the supporting structure, except that, in a unit designed for use only in a mobile home, the distance shall be not less than 19 mm (3/4 in.).

## 4 CONDENSATE DRAIN CONNECTION

Consult local codes for special requirements.

To provide extra drain protection from water damage, install an additional drain pan, provided by installer, under the entire unit with a separate drain line.

Manufacturer will not be responsible for any damages due to the failure to follow these requirements.

### 4.1 Install Drain Pipe

1. Use the provided female NPT threaded fitting for outside connection and make sure that drain holes are not blocked.
2. Insulation may be needed for drain line to prevent sweating.
3. Use a sealing compound on male pipe threads. Install the condensate drain line (NPT) to spill into an open drain.
4. Ensure a trap is included in the condensate drain line.
5. Make sure that the outlet of the trap is at least 1 in. (25mm) lower than the drain pan condensate connection to prevent the pan from overflowing (See Fig. 4-1).
6. Unit must be slightly inclined toward drain connection.(See Fig. 2-10).

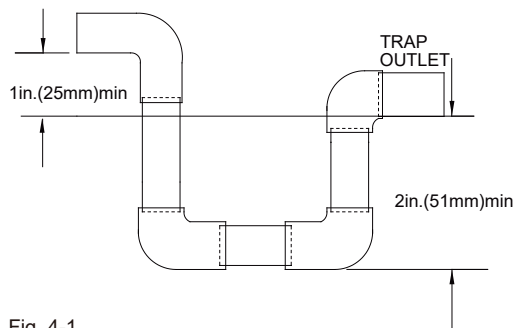

Fig. 4-1

### 4.2 Removal and Clean The Drain Pan

See above Figure.4-1 B, disconnect the Connective Tube and Drain Commutator, screw off the two fixed screws of Drain Pan, and then along with the rail pull out the Drain Pan and Connective Tube from the bottom of evaporator. Using a wet cloth or water to wash out the drain pan carefully.

## 5 FILTERS

Units are shipped without a filter or filter racks. It is the responsibility of the installer to secure a filter in the return air ductwork or install a filter/frame Kit.

Filter must always be used and must be kept clean.

When filter become dirt laden, insufficient air will be delivered by the blower, decreasing your units efficiency and increasing operation costs and wear-and tear on the unit and controls.

Filters should be checked monthly; this is especially important since this unit is used for both heating and cooling.

## 6 ELECTRICAL WIRING

Field wiring must comply with the National Electric Code (NEC) or Canadian Electrical Code (CEC) and any applicable local ordinance.

### ⚠ WARNING

Disconnect all power to unit before installing or servicing. More than one disconnect switch may be required to de-energize the equipment. Hazardous voltage can cause severe personal injury or death.

### 6.1 Power Wiring

1. Proper electrical power should be available at unit. Voltage tolerance should not be over 10% from rating voltage.
  2. If any of the wire must be replaced, replacement wire must be the same type as shown in nameplate, wiring diagram and electrical data sheet.
  3. Install a branch circuit disconnect of adequate size to handle starting current, located within sight of, and readily accessible to the unit.
  4. ELECTRIC HEATER - If the Electric Heater is installed, unit may be equipped with 30~60A. circuit breakers or fuse. These breaker(s) protect the internal wiring in the event of a short circuit and serve as a disconnect. Circuit breakers installed within the unit do not provide over-current protection of the supply wiring and therefore may be sized larger than the branch circuit protection.
    - Supply circuit power wiring must be 221 °F minimum copper conductors only. See Electrical Data in this section for ampacity, wire size and circuit protector requirements. Supply circuit protective devices may be either fuses or "HACR" type circuit breakers.
    - An 1-3/8" knockouts inside cabinet is provided for connection of power wiring to electric heater.
    - Power wiring is connected to the power terminal block in unit electric cabinet.
- See Electrical Heater Installation Instruction for details.

### 6.2 Grounding

**⚠ WARNING**

The unit must be permanently grounded. Failure to do so can result in electrical shock causing personal injury or death.

- Grounding may be accomplished by grounding metal conduit when installed in accordance with electrical codes to the unit cabinet.
- Grounding may also be accomplished by attaching ground wire(s) to ground lug(s) provided in the unit wiring compartment.

### 6.3 Control Wiring

**IMPORTANT:** Class 2 low voltage control wiring SHOULD NOT be run in conduit with main power wiring and must be separated from power wiring, unless class 1 wire of proper voltage rating is used.

- Low voltage control wiring should be 18 AWG color-coded. For lengths longer than 50 ft, 16 AWG wire should be used.
- Two 7/8" holes can be used for control wires going into the unit, one on left side and one at the bottom.
- Make sure, after installation, separation of control wiring and power wiring has been maintained.

**Thermostat** should be mounted on an inside wall about 58" from floor and will not be affected by unconditioned air, sun and/or heat exposure. Follow the instruction carefully because there are many wiring requirements.

See Fig. 6-1 ~ 2, Table 6-1

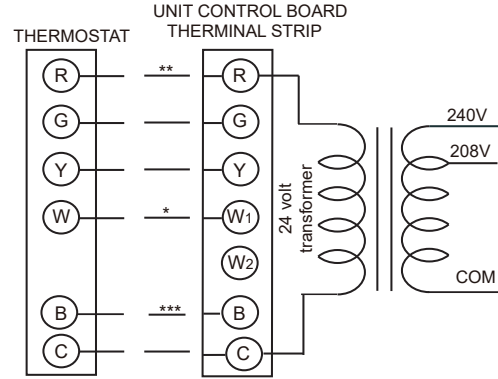

Fig. 6-1 Typical Field Control Wiring Diagram

- \*\*\* B wire be used with heat pump system only.
- \*\* Minimum wire size of 18 AWG wire should be used for all field installed 24 volt wire.
- \* Only required on units with supplemental electric heat.

**⚠ CAUTION**

Label all wire prior to disconnection when servicing controls. Wiring errors can cause improper and dangerous operation. Verify proper operation after servicing.

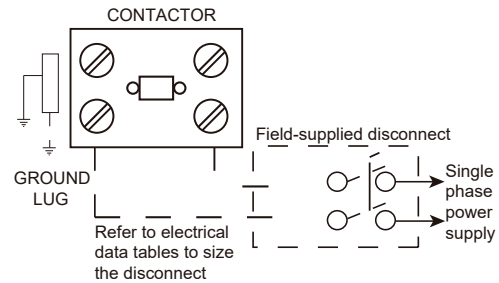

Fig. 6-2 Typical Field Power Wiring Diagram

Table 6-1: Heat Pump W/Without Electric Heat

Size (Tons)	Volt	Compressors		OD Fan Motors	ID Fan Motors	Heater Circuit (without units)					Heater Fan Speed			
		RLA	LRA	FLA	FLA	Model	kW	Stages	Amps	MCA (Amps)	Max Fuse Breaker Size(Amps)	Low	Middle	High
24(2.0)	208/230-1-60	10.0	34.8	0.61	2.0	None	-	-	None	15.1	25			
						EHK-05J	3.8/5	1	18.1/20.8	23/26	25/30	●	●	●
						EHK-08J	5.6/7.5	1	27.1/31.3	34/40	35/40	×	●	●
36(3.0)	208/230-1-60	16.0	72	1.0	3.2	None	-	-	None	24.2	40			
						EHK-05J	3.8/5	1	18.1/20.8	23/26	25/30	●	●	●
						EHK-08J	5.6/7.5	1	27.1/31.3	34/40	35/40	●	●	●
48(4.0)	208/230-1-60	23.0	108	1.9	4.0	EHK-10J	7.5/10	1	36.1/41.7	46/53	50/60	×	●	●
						EHK-15J	11.3/15	2	54.2/62.5	68/79	70/80	×	●	●
						None	-	-	None	35.1	50			
60(5.0)	208/230-1-60	26.0	127.9	1.9	5.8	EHK-05J	3.8/5	1	18.1/20.8	23/26	25/30	●	●	●
						EHK-08J	5.6/7.5	1	27.1/31.3	34/40	35/40	●	●	●
						EHK-10J	7.5/10	1	36.1/41.7	46/53	50/60	●	●	●
						EHK-15J	11.3/15	2	54.2/62.5	68/79	70/80	×	●	●
						EHK-20J	15/20	2	72.2/83.3	91/105	100/110	×	×	●
						None	-	-	None	38.4	60			

Table 6-2: Physical Data

Component	Models			
Nominal Tonnage	2.0	3.0	4.0	5.0
Volt	208/230-1-60	208/230-1-60	208/230-1-60	208/230-1-60
ARI COOLING PERFORMANCE				
ARI net capacity (Btu)	22800	34000	46500	57000
EER	10.6	10.6	10.6	10.6
SEER	13.4	13.4	13.4	13.4
Nominal CFM	800	1100	1600	1900
System power (kW)	2.15	3.21	4.39	5.38
Refrigerant type	R410a	R410a	R410a	R410a
Refrigerant charge (lb-oz)	6-6	7-15	9-4	11-14
ARI HEATING PERFORMANCE				
47 °F Capacity Rating (Btu)	22800	34200	48000	57000
System power (kW)	1.98	2.90	4.12	4.70
17 °F Capacity Rating (Btu)	11000	17000	27000	31000
System power (kW)	1.55	2.41	3.60	4.13
HSPF	6.7	6.7	6.7	6.7
DIMENSIONS (Inches)				
Length	50-11/16	50-11/16	51-9/16	51-9/16
Width	35-1/16	35-1/16	44-13/16	44-13/16
Height	46-13/16	46-13/16	51-7/16	51-7/16
OPERATING WT. (lbs)	392	408	531	562
COMPRESSORS				
Type	Rotary	Rotary	Scroll	Scroll
Quantity	1	1	1	1
CONDENSER COIL DATA				
Face area (Sq. Ft)	14.11	14.11	20.17	20.17
Rows	2+2	2+3	2+2	3+3
Fins per inch	17	17	17	17
Tube diameter	9/32	9/32	9/32	9/32
Circuitry type	interlaced	interlaced	interlaced	interlaced
EVAPORATOR COIL DATA				
Face area (Sq. Ft)	3.96	3.96	6.1	6.1
Rows	4	4	4	4
Fins per inch	17	17	17	17
Tube diameter	9/32	9/32	9/32	9/32
Circuitry type	interlaced	interlaced	interlaced	interlaced
Refrigerant control	Orifice	Orifice	Orifice	Orifice
CONDENSER FAN DATA				
Fan diameter (inch)	23-5/8	23-5/8	26-3/8	26-3/8
Type	Prop	Prop	Prop	Prop
Drive type	Direct	Direct	Direct	Direct
No. speeds	1	1	1	1
Number of motors	1	1	1	1
Motor HP each	1/12 (60W)	1/6 (110W)	1/3 (290W)	1/3 (290W)
RPM	880	840	1070	1070
Nominal total CFM	2200	2770	5100	5000
DIRECT DRIVE EVAP FAN DATA				
Quantity	1	1	1	1
Fan Size (Inch)	10×10	10×10	11×10-5/8	11×10-5/8
Type	Centrifugal	Centrifugal	Centrifugal	Centrifugal
No. speeds	1	1	1	1
Motor HP each	1/5 (150W)	1/2 (375W)	3/4 (600W)	3/4 (560W)

\* The above Table data for reference only.

## 7 AIRFLOW PERFORMANCE

Airflow performance data is based on cooling performance with a coil and no filter in place. Use this performance table for appropriate unit size, external static applied to unit and allow operation within the minimum and maximum limits shown in table below for both cooling and electric heat operation.

### 7.1 Airflow Performance Data

Table 7-1

Model Number	Motor Speed		External Static Pressure-Inches W.C.[kPa]								
			0[0]	0.1[.02]	0.2[.05]	0.3[.07]	0.4[.10]	0.5[.12]	0.6[.15]	0.7[.17]	0.8[.20]
24	Low-Factory	SCFM	/	860	767	677	593	/	/	/	/
		Watts	/	1.0	1.0	1.0	1.0	/	/	/	/
		Amps	/	229	225	222	218	/	/	/	/
	Middle	SCFM	/	/	/	900	819	736	629	/	/
		Watts	/	/	/	1.4	1.4	1.3	1.3	/	/
		Amps	/	/	/	314	309	303	298	/	/
	High	SCFM	/	/	/	/	/	868	761	653	600
		Watts	/	/	/	/	/	1.7	1.7	1.7	1.7
		Amps	/	/	/	/	/	384	376	370	365
36	Low (Tap2)	SCFM	1170	1107	1042	984	926	867	/	/	/
		Watts	1.6	1.6	1.7	1.7	1.8	1.8	/	/	/
		Amps	176	182	188	194	200	206	/	/	/
	Middle (Tap3)-Factory	SCFM	1339	1284	1224	1168	1119	1065	1014	961	900
		Watts	2.2	2.2	2.3	2.3	2.4	2.4	2.5	2.5	2.6
		Amps	254	260	266	272	279	286	294	300	305
	High (Tap4)	SCFM	/	1385	1328	1274	1226	1178	1128	1079	1031
		Watts	/	2.6	2.7	2.7	2.8	2.9	2.9	3.0	3.0
		Amps	/	315	322	328	335	342	350	357	364
48	Low-Factory	SCFM	/	/	/	1897	1804	1715	1605	1511	1403
		Watts	/	/	/	3.0	2.9	2.8	2.7	2.6	2.5
		Amps	/	/	/	685	663	643	615	582	557
	Middle	SCFM	/	/	/	/	1904	1801	1689	1557	1432
		Watts	/	/	/	/	3.2	3.1	3.0	2.9	2.8
		Amps	/	/	/	/	728	702	673	643	611
	High	SCFM	/	/	/	/	/	1873	1757	1621	1500
		Watts	/	/	/	/	/	3.4	3.3	3.2	3.0
		Amps	/	/	/	/	/	771	743	712	676
60	Low (Tap3)	SCFM	1784	1732	1675	1610	1548	/	/	/	/
		Watts	2.6	2.7	2.7	2.8	2.9	/	/	/	/
		Amps	312	321	329	337	347	/	/	/	/
	Middle (Tap4)-Factory	SCFM	2046	1996	1953	1900	1844	1790	1738	1676	1520
		Watts	3.7	3.8	3.9	3.9	4.0	4.1	4.2	4.3	4.6
		Amps	459	471	481	492	503	514	527	538	577
	High (Tap5)	SCFM	/	2227	2185	2142	2094	2042	1991	1938	1761
		Watts	/	5.1	5.2	5.2	5.3	5.4	5.5	5.6	5.7
		Amps	/	646	658	670	683	695	709	724	735

- The air distribution system has the greatest effect on airflow. The duct system is totally controlled by the contractor. For this reason, the contractor should use only industry-recognized procedures.
- Heat pump systems require a specified airflow. Each ton of cooling requires between 350 and 450 cubic feet of air per minute (CFM), or 400 CFM nominally.
- Duct design and construction should be carefully done. System performance can be lowered dramatically through bad planning or workmanship.
- Air supply diffusers must be selected and located carefully. They must be sized and positioned to deliver treated air along the perimeter of the space. If they are too small for their intended airflow, they become noisy. If they are not located properly, they cause drafts. Return air grilles must be properly sized to carry air back to the blower. If they are too small, they also cause noise.
- The installers should balance the air distribution system to ensure proper quiet airflow to all rooms in the home. This ensures a comfortable living space.
- An air velocity meter or airflow hood can give a reading of system CFM.
- When installation, installer should select the air speed according to the actual setting static pressure. Please refer to the Table 7-1 AIRFLOW PERFORMANCE DATA.

## 8 SYSTEM OPERATION

### 8.1 Compressor Crankcase Heater (Optional)

Refrigerant migration during the off cycle can result in a noisy start up. Add a crankcase heater to minimize refrigeration migration, and to help eliminate any start up noise or bearing “wash out”.

All heaters are located on the lower half of the compressor shell. Its purpose is to drive refrigerant from the compressor shell during long off cycles, thus preventing damage to the compressor during start-up.

At initial start-up or after extended shutdown periods, make sure the heater is energized for at least 12 hours before the compressor is started. (Disconnect switch on and wall thermostat off.)

**The crankcase heater will start up or shut down according to the following logic:**

The crankcase heater will start up when the compressor is off and  $T4 < 41^{\circ}\text{F}$ .

The crankcase heater will shut down when  $T4 \geq 44.6^{\circ}\text{F}$ .

In any condition, the crankcase heater will shut down when the compressor is on

### 8.2 Protection

#### 8.2.1 Protection for HP system If sensors (T3&T4)

become open-circuit or short-circuit, the compressor , outdoor fan motor and reversing valve circuit will shut down.

Discharge temperature protection:

If discharge temp. is  $> 275^{\circ}\text{F}(4T\setminus 5T)$  ,the compressor will shut down, If discharge temp. is  $< 194^{\circ}\text{F}(4T\setminus 5T)$  , the compressor will resume operation.

If discharge temp. is  $> 239^{\circ}\text{F}(2T\setminus 3T)$ ,the compressor will shut down, If discharge temp. is  $< 167^{\circ}\text{F}(2T\setminus 3T)$  , the compressor will resume operation.

#### High pressure protection

If high pressure is  $> 638\text{PSIG}$ ,the compressor and the outdoor fan motor will stop running.

If high pressure is  $< 464\text{PSIG}$ ,the compressor and the outdoor fan motor will resume running(3 minutes delay necessary ).

#### Outdoor coil temperature protection (T3)

If  $T3 > 147.2^{\circ}\text{F}$ , compressor is de-energized

If  $T3 < 125.6^{\circ}\text{F}$ , compressor is energized.

#### Low pressure protection

When low pressure is  $< 21\text{PSIG}$ ,the compressor and the outdoor fan motor will stop running.

When low pressure is  $> 44\text{PSIG}$ ,the compressor and the outdoor fan motor will resume running(3 minutes delay necessary ).In stand-by status, if low pressure protection was detected, the compressor will not start.

If protection cycles occur four times within 30 minutes, the compressor and outdoor fan will shut down. In this condition, the system needs to power on once more in order to keep on working.

#### T4 function:

- i. If  $50^{\circ}\text{F} \leq T4 < 125^{\circ}\text{F}$ , unit can operate in cooling
- ii. If  $5^{\circ}\text{F} \leq T4 < 77^{\circ}\text{F}$ , unit can operate in heating

When  $T4$  is  $< 5^{\circ}\text{F}$ , the compressor will stop. If the electrical heater kit is installed in the indoor unit, the outdoor unit will send the operation signal to the indoor unit. When  $T4$  is  $> 10.4^{\circ}\text{F}$ , the compressor will restart .

### 8.3 Defrost Mode\* (For HP System Only)

#### Manual defrost mode

To manually cycle the defrost mode, set switch SW3-1 to the “ON” position (See Fig 7). The system will engage a defrost cycle, and automatically exit defrost mode once the **Shut-down conditions of defrost mode** described below are met.

**Caution:**Once the manual defrost mode is finished, please set switch SW3-1 back to “OFF”.

#### Start-up conditions of defrost mode:

When SW3-3 switch is set to “ON”(See Fig 7), the system will perform a defrost cycle in any of the following conditions:

1. If the compressor is operating and  $T3$  is  $< 30.2^{\circ}\text{F}$ , the system will perform a defrost cycle every 30 minutes of operation.
2. When  $T3$  is  $< 28.4^{\circ}\text{F}$  and the compressor is operating for the first time after being connected power.
3. When  $T3$  is  $< 28.4^{\circ}\text{F}$  and The system has been in standby for two hours .

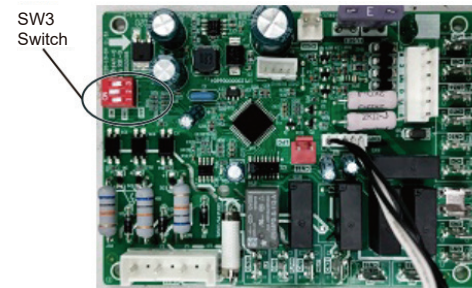

Fig.7 SW3 Switch Location in the PCB Board (For reference only)

SW3	SW3-1	ON	MANUAL DEFROST
		OFF	AUTOMATIC DEFROST
	SW3-2	ON	INTELLIGENT DEFROST
		OFF	NORMAL DEFROST
	SW3-3	ON	DEFROSTING CYCLE:60MIN
		OFF	DEFROSTING CYCLE:30MIN

When SW3-3 switch is set to “OFF”(See in Fig 7), the system will perform a defrost cycle in any of the following conditions:

1. If the compressor is operating and  $T3$  is  $< 30.2^{\circ}\text{F}$ , the system will perform a defrost cycle every 60 minutes of operation.
2. When  $T3$  is  $< 28.4^{\circ}\text{F}$  and the compressor is operating for the first time after being connected power.
3. When  $T3$  is  $< 28.4^{\circ}\text{F}$  and the system has been in standby for two hours .

**Shut-down conditions of defrost mode:**

The mode will shut down in any of the following conditions:

1. The defrosted time lasting for 10 minutes;
2. T3 is  $\geq 77$  °F when T4  $\geq 28.4$  °F;
3. Compressor stop operating;
4. T3 is  $\geq 77$  °F last for 60s when T4  $< 28.4$  °F.

### 8.4 Thermostat Signals

Table 8-1: Thermostat Signals

Signal	State	Board Function
G	ON	Blower instant ON
	OFF	Blower 90 sec. delay OFF
G & W1	ON	Blower instant ON Heater bank 1 elec.onstant ON
	OFF	Heater bank 1 elec.instant OFF Blower 90 sec. delay OFF
G & W & W2	ON	Blower instant ON Heater 1 instant ON Heater 2 instant ON
	OFF	Blower 90 sec. delay OFF Heater 1 instant OFF Heater 2 instant OFF
G & Y	ON	Blower instant ON Compressor and outdoor fan instant ON
	OFF	Compressor and outdoor fan instant OFF Blower fan delay 90 sec. OFF
G & B & Y	ON	Blower instant ON Compressor and outdoor fan instant ON 4-way valve instant ON
	OFF	Compressor and outdoor fan instant OFF Blower fan delay 90 sec. OFF 4-way valve instant OFF
G & B & Y & W1	ON	Blower instant ON Compressor and outdoor fan instant ON 4-way valve instant ON Heater 1 instant ON
	OFF	Blower fan delay 90 sec. OFF Compressor and outdoor fan instant OFF 4-way valve instant OFF Heater 1 instant OFF
G & B & Y & W1 & W2	ON	Blower instant ON Compressor and outdoor fan instant ON 4-way valve instant ON Heater 1 instant ON Heater 2 instant ON
	OFF	Blower fan delay 90 sec. OFF Compressor and outdoor fan instant OFF 4-way valve instant OFF Heater 1 instant OFF Heater 2 instant OFF

## 9 OPERATION CHECK-UP

• **Cooling Startup**

1. Turn thermostat to OFF and turn power to ON
2. Turn ON thermostat and set as high as possible
3. Turn Fan switch ON and indoor blower should run
4. Turn fan switch to AUTO, system switch to COOL and thermostat tem perature setting below room temperature.  
Unit should run in COOLING mode.

• **Heating Startup**

- After normal cooling run
1. Turn thermostat switch to HEAT. After unit stops, wait about 5 minutes.
  2. Turn thermostat setting above room temperature.  
Unit should run in HEATING mode.

After unit has run for a while, check the following:

1. Are fans running properly?
2. Is compressor running correctly?
3. Check refrigerant charge.
4. Check duct connection for leaks.
5. Check for tubing and sheet metal rattles.

(See Wiring Diagram for electric connection detail.)

## 10 TROUBLE SHOOTING

**⚠ WARNING**

Component trouble shooting requires opening control box with power on. Use extreme care while working on this condition. Check nameplate and this instruction when making wire connections.

**💡 NOTE**

When the outdoor temperature is between 50°F and 67°F, the compressor can only run for cooling within a short time, otherwise it may cause damage to compressor.

**ILLUSTRATION FOR COVERING SIDE OPENINGS FOR DOWNFLOW APPLICATION****FOAM STICKED METHOD:**

1. Use two covers from bottom openings to cover the side openings.
2. Use four sticking foam tapes provided in accessory bag and stick tapes on covers. See FIG.1 and 2.
3. Place the covers on supply and return openings and use screws and washers provided to hold covers. See FIG.3.
4. Use silicon sealant to seal four sides of covers to prevent water from coming into equipment.

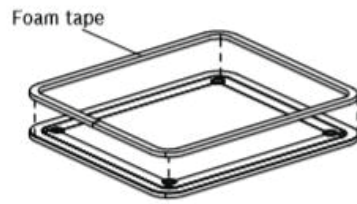

FIG.1



FIG.2

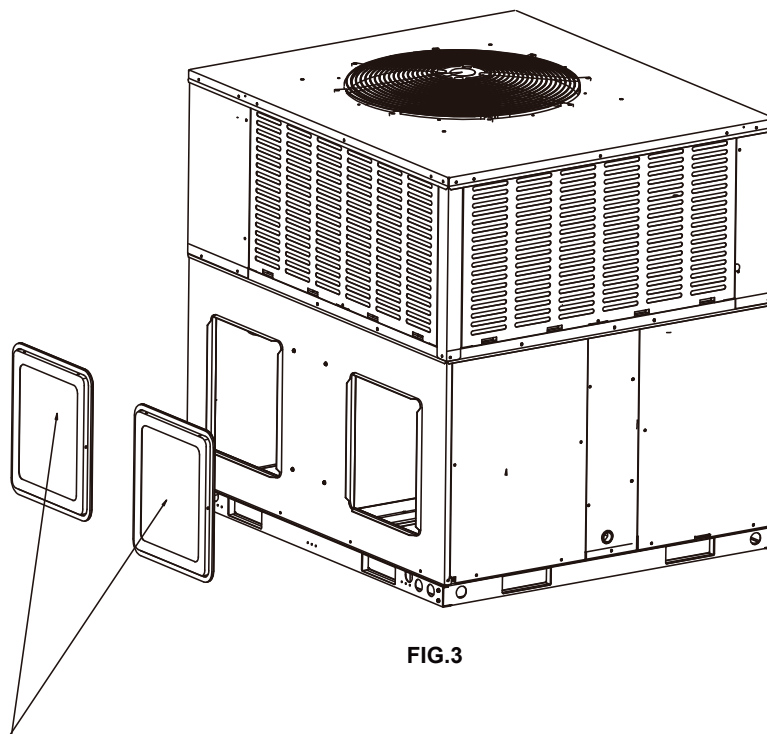

FIG.3

Return/Supply duct cover  
(attach with 4 screws)



## SE SERIES LIMITED WARRANTY

Congratulations on purchasing your new HVAC equipment.

Your unit automatically qualifies for the warranty coverage listed below provided you meet the warranty conditions.

### YEAR 1 PRODUCT REPLACEMENT

If the heat exchanger, evaporator coil (packaged systems only), condenser coil, or compressor fails within the first year (365 days) after the date of installation to the original consumer for the original installation, the original purchase cost of the unit will be reimbursed to the authorized Comfort-Aire/Century distributor who has received prior authorization from Comfort-Aire/Century for the failure. The owner is responsible for additional labor, freight, and miscellaneous charges. Units installed in a commercial application, defined as any application other than a residential/multifamily (personal, family or household) purpose, are not eligible for the one year product replacement.

### LIMITED WARRANTY

All parts are warranted to be free from defects in workmanship and materials for normal residential use and maintenance for five (5) years from the date of purchase by the original consumer for the original residential installation. The compressor and the heat exchanger are warranted to be free from defects in workmanship and materials for normal residential use and maintenance for ten (10) years from the date of purchase by the original consumer for the original residential installation.

### LIMITED EXTENDED WARRANTY

When registered with Comfort-Aire/Century, the heat exchanger is warranted to be free from defects in material and workmanship for twenty (20) years and all parts are warranted to be free from defects in material and workmanship for ten (10) years from the date of purchase by the original consumer for the original installation.

### DURATION OF WARRANTY

The warranty begins on the date of purchase by the original consumer (homeowner). The original consumer must retain a receipted bill of sale or invoice showing model and serial number as proof of the warranty period initiation.

### CONDITIONS FOR WARRANTY COVERAGE

Unit must be properly installed and maintained by a licensed HVAC service provider in accordance with the installation, operation, and maintenance instructions provided with each unit. Unit cannot have been subjected to accident, alteration, improper repair, neglect/misuse, or force majeure. Proof of proper maintenance over the lifetime of the unit must be supplied. Performance cannot be impaired by use of any product not authorized by Comfort-Aire/Century, or by any adjustments or adaptations to components. Serial numbers and/or rating plate have not been altered or removed. Damage has not been a result of inadequate wiring or voltage conditions, use during brown-out conditions, or circuit interruptions. Unit remains in the original residential installation and is not transferrable. Unit was not purchased over the internet or at auction. Non-approved refrigerant and/or non-approved system additives will void this warranty.

### WARRANTY EXCEPTIONS

The Limited Express Warranty does not cover costs associated with normal maintenance, utility usage, labor, shipping and handling, or collateral damage. It also does not cover any portion or component of the system that is not supplied by Comfort-Aire/Century, regardless of the cause of failure of such portion or component.

### LIMITATION OF LIABILITY

There are no other express or implied warranties. Comfort-Aire/Century makes no warranty of merchantability and does not warrant that the unit is suitable for any particular purpose, building, room size, or condition except as specifically provided in this document. There are no other warranties, express or implied, which extend beyond the description in this document. All warranties implied by law are limited in duration to the five-year term of the Parts Warranty. Your exclusive remedy is limited to the replacement of defective parts. Comfort-Aire/Century will not be liable for any consequential or incidental damages caused by any defect in this unit. This warranty gives you specific legal rights and you may also have other rights which vary from state to state. Some states do not allow a limitation on how long an implied warranty lasts or do not allow the exclusion or limitation of incidental or consequential damages, so the above limitations or exclusions may not apply to you. No warranties are made for units sold outside the continental United States and Canada. Your distributor or final seller may provide a warranty on units sold outside these areas. Comfort-Aire/Century will not be liable for damages if our performance regarding warranty resolution is delayed by events beyond our control including accident, alteration, abuse, war, government restrictions, strikes, fire, flood, or force majeure.

### KEEP THIS INFORMATION AS A RECORD OF YOUR PURCHASE

Apply Serial Number and Model Number sticker here (from product carton). If unavailable, write serial number and model number below (can be found on unit rating plate).

Date of Purchase \_\_\_\_\_ Date Installation Completed \_\_\_\_\_

Component of new HVAC system  Replacement furnace only

Remember to retain your bill of sale as proof of warranty period and ownership.



Please visit [www.heatcontroller.com](http://www.heatcontroller.com)  
to register your new product.

**Page Intentionally Left Blank**

**Page Intentionally Left Blank**

**Page Intentionally Left Blank**

Due to ongoing product improvements, specifications and dimensions are subject to change and correction without notice or incurring obligations. Determining the application and suitability for use of any product is the responsibility of the installer. Additionally, the installer is responsible for verifying dimensional data on the actual product prior to beginning any installation preparations.

Incentive and rebate programs have precise requirements as to product performance and certification. All products meet applicable regulations in effect on date of manufacture; however, certifications are not necessarily granted for the life of a product. Therefore, it is the responsibility of the applicant to determine whether a specific model qualifies for these incentive/rebate programs.

