

---

*Comfort-Aire*®

---

# **OWNER'S MANUAL**

**Room Air Heat Pump  
with R-32:  
RAH-123R**



# CONTENTS

■ Safety precautions . . . . .	1
■ Operation environment . . . . .	2
■ Introduction . . . . .	3
■ Safety Information . . . . .	3
■ Normal Care and Maintenance . . . . .	5
■ Installation Requirements . . . . .	7
■ Electrical Requirements . . . . .	8
■ Installation Instructions . . . . .	10
■ Complete Installation . . . . .	13
■ General Operating Instructions . . . . .	14
■ Operating Controls . . . . .	15
■ Preventative Maintenance . . . . .	19
■ Before Calling Service . . . . .	20
■ When Service Is Required . . . . .	20
■ Any Questions . . . . .	20
■ Specialist's manual . . . . .	21



This symbol stands for the items should be forbidden



This symbol stands for the items should be followed

The figures in this manual may be different with the material objects, please refer to the material objects for reference.

It's not allowed to be installed on the unstable or motive base structure (such as truck) or in the corrosive environment (such as chemical factory).



Do not dispose this product as unsorted municipal waste. Collection of such waste separately for special treatment is necessary.

## Explanation of Symbols



Indicates a hazardous situation that, if not avoided, will result in death or serious injury.



Indicates a hazardous situation that, if not avoided, could result in death or serious injury.



Indicates a hazardous situation that, if not avoided, may result in minor or moderate injury.



Indicates important but not hazard-related information, used to indicate risk of property damage.



Indicates a hazard that would be assigned a signal word WARNING or CAUTION.

## Exception Clauses





Manufacturer will bear no responsibilities when personal injury or property loss is caused by the following reasons.

1. Damage the product due to improper use or misuse of the product;
2. Alter, change, maintain or use the product with other equipment without abiding by the instruction manual of manufacturer;
3. After verification, the defect of product is directly caused by corrosive gas;
4. After verification, the defects are due to improper operation during transportation of product;
5. Operate, repair, maintain the unit without abiding by instruction manual or related regulations;
6. After verification, the problem or dispute is caused by the quality specification or performance of parts and components that produced by other manufacturers;
7. The damage is caused by natural calamities, bad using environment or force majeure.

If it needs to install, move or maintain the air conditioner, please contact dealer or local service center to conduct it at first. Air conditioner must be installed, moved or maintained by appointed unit. Otherwise, it may cause serious damage or personal injury or death.

When refrigerant leaks or requires discharge during installation, maintenance, or disassembly, it should be handled by certified professionals or otherwise in compliance with local laws and regulations.

## The refrigerant

 A2L with flammable gas R32.	 Before install the appliance, read the installation manual first.
 Before use the appliance, read the owner's manual first.	 Before repair the appliance, read the service manual first.

- To realize the function of the air conditioner unit, a special refrigerant circulates in the system. The used refrigerant is the fluoride R32, which is specially cleaned. The refrigerant is flammable and inodorous. Furthermore, it can lead to explosion under certain conditions. But the flammability of the refrigerant is very low. It can be ignited only by fire.
- Compared to common refrigerants, R32 is a nonpolluting refrigerant with no harm to the ozoneosphere. The influence upon the greenhouse effect is also lower. R32 has got very good thermodynamic features which lead to a really high energy efficiency. The units there fore need a less filling.

### WARNING

- Appliance filled with flammable gas R32
- Appliance shall be installed,operated and stored in a room with a floor area larger than 4m<sup>2</sup>.
- The appliance shall be stored in a room without continuously operating ignition sources.  
(for example:open flames,an operating gas appliance or an operating electric heater.)
- The appliance shall be stored in a well-ventilated area where the room size corresponds to the room area as specified for operation.
- The appliance shall be stored so as to prevent mechanical damage from occurring.
- Ducts connected to an appliance shall not contain an ignition source.
- Keep any required ventilation openings clear of obstruction.
- Do not pierce or burn.
- Be aware that refrigerants may not contain an odour.
- Do not use means to accelerate the defrosting process or to clean,other than those recommended by the manufacturer.
- Servicing shall be performed only as recommended by the manufacturer.

- Should repair be necessary,contact your nearest authorized Service Centre. Any repairs carried out by unqualified personnel may be dangerous.
- Compliance with national gas regulations shall be observed.
- Read specialist's manual.



## Safety precautions



### WARNING

- This appliance can be used by children aged from 8 years and above and persons with reduced physical, sensory or mental capabilities or lack of experience and knowledge if they have been given supervision or instruction concerning use of the appliance in a safe way and understand the hazards involved.
- Children shall not play with the appliance.
- Cleaning and user maintenance shall not be made by children without supervision.
- Before operation, please confirm whether power specification complies with that on nameplate.
- Before cleaning or maintaining the air conditioner, please turn off air conditioner and pull out the power plug.
- Make sure the power cord hasn't been pressed by hard objects.
- Do not pull or drag the power cord to pull out the power plug or move the air conditioner.
- Do not insert or pull out the power plug with wet hands.
- Please use the grounded power. Make sure the grounding is reliable.
- If the SUPPLY CORD is damaged, it must be replaced by the manufacturer, its service agent or similarly qualified persons in order to avoid a hazard.
- If abnormal condition occurs (e.g. burned smell), please disconnect power at once and then contact local dealer.
- When nobody is taking care of the unit, please turn it off and remove the power plug or disconnect power.
- Do not splash or pour water on air conditioner. Otherwise, it may cause short circuit or damage to air conditioner.
- Prohibit operating heating equipment around the air conditioner.
- Prohibit operating the unit in the bathroom or laundry room.
- Far away from fire source, inflammable and explosive objects.
- Children and disabled people are not allowed to use the portable room air conditioner without supervision.
- Keep children from playing or climbing on the air conditioner.
- Do not put or hang dripping objects above the air conditioner.
- Do not repair or disassemble the air conditioner by yourself.
- Do not block air outlet or air inlet.

# Safety precautions



- Prohibit inserting any objects into the air conditioner.
- Do not through sundries into the air duct. If there are sundries get into the air duct, please contact the professionals to deal with it.
- Do not use an extension cord.
- Specification of fuse on the main board:T3.15AH250V(unit: 208/230V)、 T3.15A 350VAC(unit: 265V); the maximum current passes through.
- The appliance shall be installed in accordance with national wiring regulations.
- The external static pressure is 0MPa for the air conditioner at the test position.
- The minimum clearance from the appliance to combustible surface:1.5m.
- As for the mode with electric heating, the electric heater is installed at the back side of indoor evaporator.Please refer to the Service Manual for details.
- If a STATIONARY APPLIANCE is not fitted with a SUPPLY CORD and a plug,an all-pole disconnection switch having a contact separation of at least 3mm in all poles should be connected in fixed wiring.

## Operation environment

Operating Temperature Range		
	Indoor side DB/WB(°F/°C)	Outdoor side DB/WB(°F/°C)
Maximum Cooling	90/73(32.2/22.8)	110/78(43.3/25.6 )
Maximum RC Heating	80/- (26.7/ - )	75/65 (23.9/18.3)
Maximum Electric Heating	77/ - (25/-)	77/ - (25/-)

Ambient temperature range (indoor temperature) for cooling is 64-90°F(18-32.2°C),  
Ambient temperature range (outdoor temperature) for cooling is 64-110°F(18-43.3°C),  
Ambient temperature range (indoor temperature) for heat pump is 41-80°F(5-26.7°C),  
Ambient temperature range (outdoor temperature) for heat pump is 55-75°F(13-24°C),  
Ambient temperature range (outdoor temperature) for Electric Heating is 19-77°F(-7-25°C).

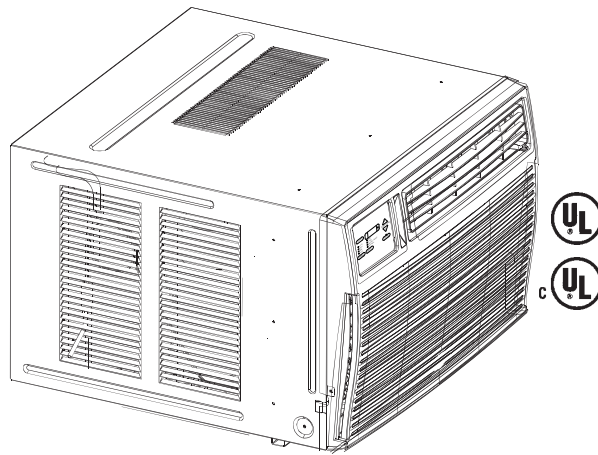

## Introduction

Room air conditioners cool, dehumidify, and filter air inside your home. Heat pump and electric heat models offer both heating and cooling. Opening sections of manual provide general information for all room air conditioner models. Operating Controls section describes operation of controls for each model. After reading the opening sections, turn to Operating Controls section and find the panel layout that matches the model of your unit.

Read entire manual thoroughly before beginning installation and operation of your new room air conditioner. Be sure you have all necessary tools and materials on hand for the job. Study illustrations to familiarize yourself with important details of the installation process. Review manual for operating instructions.

This appliance is not intended for use by persons (including children) with reduced physical, sensory or mental capabilities, or lack of experience and knowledge, unless they have been given supervision or instruction concerning use of the appliance by a person responsible for their safety. Children should be supervised to ensure that they do not play with the appliance.

## Safety Information

Be sure electrical service is adequate for chosen model of air conditioner. Complete electrical rating for unit is found on serial plate located behind front grille. Electrical outlet must be close enough to unit for power cord to reach without strain. Air conditioner should be the only appliance on individual circuit.

For personal safety and to avoid possible damage to appliance or home, observe all safety instructions highlighted by symbol shown below.

## NOTICE:

1. Mechanical experience is required to install air conditioner.
2. Installation can take from 1 to 3 hours, depending on installer's knowledge and skill.
3. If you encounter problems during installation, call our consumer information line at (86-756) 8617555. If your problem cannot be resolved by phone, contact an authorized GREE® brand servicer. Contact and service will be at your expense.
4. Do not install or place anything in the air inlet and air outlet of window type unit, in order to avoid affecting performance.



## RECOGNIZE THIS SYMBOL AS A SAFETY PRECAUTION.

After installing unit, reread instructions to ensure each step is complete and that all parts are fastened in place. For best results and to minimize installation time, perform all procedures in the order shown.

This appliance can be used by children aged from 8 years and above and persons with reduced physical, sensory or mental capabilities or lack of experience and knowledge if they have been given supervision or instruction concerning use of the appliance in a safe way and understand the hazards involved. Children shall not play with the appliance. Cleaning and user maintenance shall not be made by children without supervision.



## WARNING

Instructions for installation and use of this product are provided by the manufacturer.

To prevent heat related illness or death, do not use this device for unattended cooling of persons or animals unable to react to product failure. Failure of unattended air conditioner may result in extreme heat in area intended for cooling, causing heat-related illness or death of persons or animals.



## WARNING

### HIGH TEMPERATURE STRESS HAZARD

This room air conditioner is not meant to provide unattended cooling or life support for persons or animals that are unable to react to failure of the product.

The failure of an unattended air conditioner may result in extreme heat in the conditioned space causing overheating or death of persons or animals.

Precautions must be taken to ward off or guard against such an occurrence.

## Unpacking

Unpack and visually inspect the unit. Report any damage to the delivering carrier immediately. Remove and discard all packing material.



## WARNING

Do NOT operate unit with shipping foam blocks in place. Always remove prior to running unit.

On some models the air conditioner front and/or mounting kit hardware may be packed separately.

Record the model, serial and manufacturing numbers of your unit in the space provided below. This information is found on a nameplate visible after the front of the air conditioner has been removed. The rated voltage, amperage and capacity for your specific model can also be found on this nameplate.

Read the warranty packaged with the unit. Keep the warranty and a copy of your sales receipt for future reference. You may also want to record in the space provided the date purchased and the selling dealer.

## OWNER'S PRODUCT IDENTIFICATION

MODEL NUMBER

SERIAL NUMBER

MANUFACTURING NUMBER

Owner's Name

Address

City State Zip

/ /

Date of Purchase

Authorized Dealer

Address

City State Zip

( )

Phone Number



## WARNING









To avoid death, personal injury or property damage due to electrical shock:

- Observe all local codes and ordinances.
- Disconnect electrical power to unit before servicing.
- Ground appliance properly.
- Check with a qualified electrician if you are not sure this appliance is properly grounded.
- DO NOT ground to gas line.
- DO NOT ground to cold water pipe if pipe is interrupted by plastic, non-metallic gaskets, or other insulating (non-conducting) materials.
- DO NOT modify plug on power cord. If plug does not fit electrical outlet, have proper outlet installed by qualified electrician.
- DO NOT have a fuse in the neutral or ground circuit. A fuse in the neutral or ground circuit could result in an electrical shock.
- DO NOT use an extension cord with this appliance.
- DO NOT use an adapter plug with this appliance.
- DO NOT pinch power cord.
- DO NOT REMOVE warning tag from power cord.

## Electrical Requirements

### Grounding Instructions

This appliance is equipped with a three-prong grounding plug for protection against possible shock hazards. If a two-prong

Unit Plug Type	Receptacle Required	Circuit Rating, Breaker, Time Delay Fuse	Voltage Rating On Nameplate
NEMA No. 5-15P 	NEMA No. 5-15R 	125V-15AMP	115V
NEMA No. 6-15P 	NEMA No. 6-15R 	250V-15AMP	230/208V rated at 12 amperes or less
NEMA No. 6-20P 	NEMA No. 6-20R 	250V-20AMP	230/208V rated over 12 amperes, but not more than 16 amperes
NEMA No. 6-30P 	NEMA No. 6-30R 	250V-30AMP	208V rated over 16 amperes, but not more than 24 amperes

When a two-prong wall receptacle is encountered, the customer is required to contact a qualified electrician and have the two-prong wall receptacle replaced with a properly grounded three-prong wall receptacle in accordance with the National Electrical Code.

Room air conditioners are designed to operate according to requirements on the nameplate and as shown in Table 1. Fuse or circuit breaker ratings must be according to the fuse instruction label and as shown in Table 1. Do not plug models marked "Use on Single Outlet Circuit Only" into a circuit with another appliance or light fixture.

#### Receptacle Wiring

Receptacle wiring must be of adequate size for unit. Refer to unit identification plate for exact power requirements. Minimum size of wiring, based on power requirements, is:

Units up to 20 amps: 12 gauge  
20–30 amp units: 10 gauge

#### LCDI or AFCI Power Cords

Underwriters Laboratories (UL) and the National Electric Code (NEC) now require power cords that sense current leakage and can open the electrical circuit to the unit. In the event, the unit does not operate, check the reset button located on or near the head of the power cord as part of the normal troubleshooting procedure.

Use copper wire only. Consumer's responsibility is to provide proper and adequate receptacle wiring that conforms to all applicable codes. All wiring should be installed by qualified electrician.

#### Installation

Complete step-by-step installation instructions are furnished with your unit. These instructions will be found on a separate

page included with this manual or in the mounting kit assembly. Follow these instructions carefully. Keep these instructions with this manual for future reference. Your unit will be one of the following three designs:

- Unit with a window mounting kit  
These models are designed for mounting through an opening in a wall. These units can be adapted to window installation by using the optional window mounting kit supplied with your unit.
- Unit without a window mounting kit  
No window mounting kit is supplied with the unit. These models are designed for mounting through an opening in a wall. These units can be adapted to window installation by purchasing an optional window mounting kit. Consult your dealer to choose the kit that is appropriate for your model and installation.

#### Room Heat Pumps

Heat pumps work by moving heat instead of creating it. In the summer, the cool indoor coil absorbs heat from your room and moves it outdoors, providing cooling. In the winter, heat pumps reverse this operation. By lowering the temperature of the outdoor coil below the outdoor temperature, the heat pump absorbs the heat from outdoors and moves it inside your house. This heat transferring process is very efficient. For example, at 45°F outdoor temperature, a heat pump can provide 2 ½ watts of heat for every watt of electricity it consumes.

As outdoor temperatures drop, the heating capacity and efficiency of the heat pump declines. At temperatures below 45°F, it is likely that ice will form on the outdoor coil. Heat pump units are designed to operate as a heat pump above approximately 40°F. Below 40°F, these units switch automatically from reverse cycle heat pump to auxiliary electric heating. No defrost is required. There is no minimum operating temperature.

#### Normal Care and Maintenance



#### CAUTION

Installing an air conditioner through a wall requires extensive carpentry and/or masonry experience. Thru-wall installations performed by inexperienced or unqualified individuals can result in costly damage to home.

#### Annual Inspection

It is suggested that your unit be inspected by your dealer or servicer once a year. It is advisable to have the outer case removed and the unit thoroughly cleaned.

**NOTICE:** The life of your unit may be greatly reduced if you live in a salt air or other corrosive type environment. Under these conditions, the unit should be removed from its case and completely cleaned at least once a year. At that time any scratches or blisters on the painted surfaces should be sanded and repainted. Placing an algaecide tablet in the outdoor side of the unit's basepan is suggested in humid areas where algae formation is common.

### Front Grille and Filter Removal

The front contains an air filter that can be removed on left or right side of front. To clean the filter use one of the following methods for filter removal:

#### METHOD ONE

Grasp filter handle and slide filter out of unit.

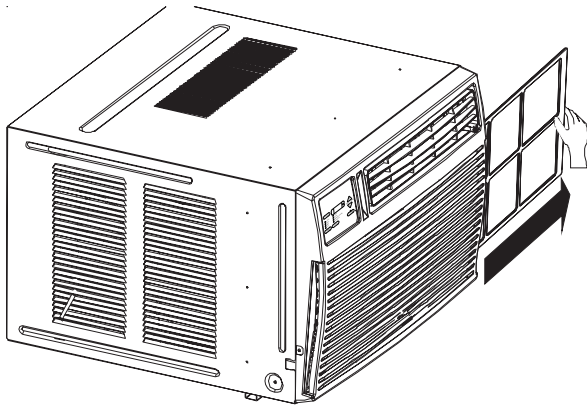

Reinstall air filter by reversing removal procedure.

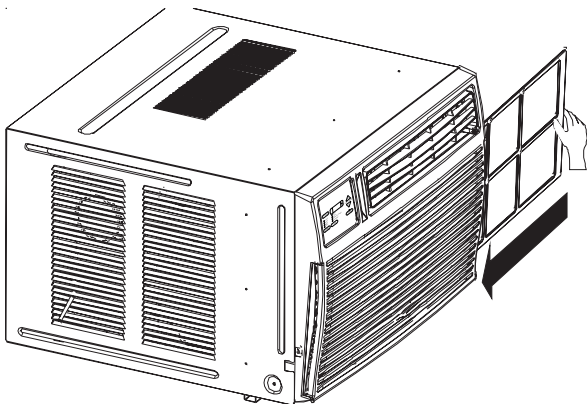

### Front Grille and Cabinet Cleaning

Grille and cabinet may be cleaned with warm water and mild soap or detergent. Cleaning and polishing compounds are not recommended, as they may damage plastic surfaces.

### Air Filter Cleaning

A dirty air filter reduces operating efficiency of unit. Filter should be inspected at least once every week during operation. Clean filter with vacuum cleaner or wash in warm water and mild detergent. Filter should be thoroughly dried before replacing in unit. Do not operate unit without filter in place.

### Fan Motor Care

The fan motor is permanently lubricated for long life. There is no need to oil the motor.

### Slide-out Chassis Removal from Outer Case

1. Remove two side ground screws attaching case to chassis basepan.
2. Remove two control knobs.
3. Remove two side Phillips screws attaching front panel to case.
4. If the unit has a screw holding the basepan clip to the chassis, remove the screw.



### CAUTION

To reduce the risk of personal injury be sure to have sufficient help when moving your unit. A room air conditioner can weigh between 70 and 240 pounds.

5. Using basepan handle, pull chassis straight out, slowly and evenly, until approximately 9-12 inches extends from outer case. Use both hands to grasp basepan and pull remaining chassis from outer case.

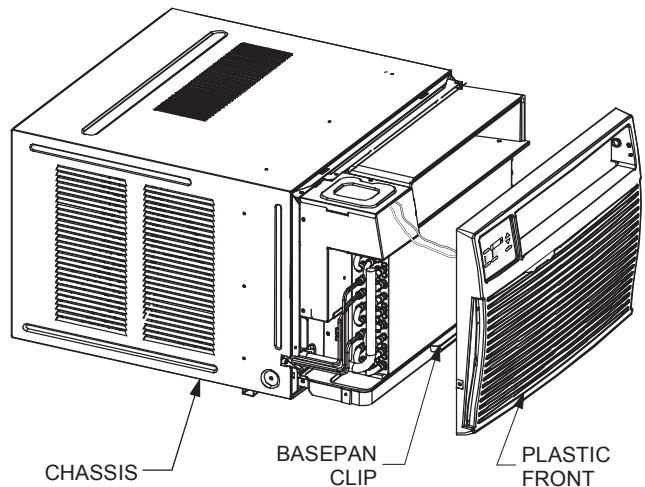

**NOTICE:** Basepan clip is shipped in plastic bag with mounting screw and condensate drain cup. Install clip after reinserting chassis into outer case to prevent accidental chassis removal.

## IMPORTANT SAFETY INSTRUCTIONS

- ⚠ WARNING:** To reduce the risk of fire, electrical shock or injury when using your air conditioner, follow these basic precautions:
- Plug into a grounded 3 prong outlet.
  - Do not use an extension cord.
  - Do not remove ground prong.
  - Unplug air conditioner before servicing.
  - Do not use an adapter.
  - Use two or more people to move and install air conditioner.

SAVE THESE INSTRUCTIONS

# INSTALLATION REQUIREMENTS

## Tools and Parts

Gather the required tools and parts before starting installation. Read and follow the instructions provided with any tools listed here.

### Tools Needed

- Flat-blade and Phillips screwdrivers
- Tape measure
- Level
- Drill and  $\frac{3}{16}$ " or smaller bit

### Through-the-wall installation:

In addition to the tools listed above, the following tools are needed for through-the-wall installation.

- Saw
- 1" or thicker lumber
- Wood preservative
- 7 - #10 x 1" wood screws
- Caulk

### Parts supplied (on some models)

Check that all parts are included in parts package.

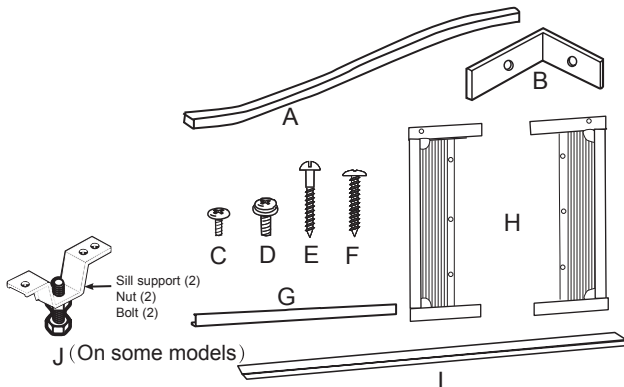

- A. Foam window sash seal
- B. Window lock brackets (2)
- C. #10 x  $\frac{1}{4}$ " pan-head Phillips screws (6)
- D. #10 x  $\frac{3}{8}$ " pan-head Phillips screws (3 or 7)
- E. #10 x  $\frac{3}{4}$ " round-head screws (6)
- F. #10 x  $\frac{1}{2}$ " pan-head Phillips screws (3)
- G. Top channel
- H. Side curtains (2)
- I. Foam seal
- J. Sill support (2) Nut (2) Bolt (2) (On some models)

**NOTICE:** Installation parts are supplied for double-hung windows up to 40" wide. A special Wide Window Kit is available from your dealer or service center. See "Accessories."

## Location Requirements

**IMPORTANT:** Observe all governing codes and ordinances. Check the location where air conditioner will be installed. Proper installation is your responsibility. Make sure you have everything necessary for correct installation.

The location should provide:

- Grounded electrical outlet within 4 ft of where the power cord exits the air conditioner.

**⚠ WARNING:** Do not use an extension cord.

- Free movement of air in room to be cooled.
- A large enough opening for the air conditioner.
- Adequate wall support for weight of air conditioner. Air conditioner weighs between 94 and 103 lbs

**NOTICE:** Cabinet louvers must not be obstructed. Air must be able to pass freely through the cabinet louvers.

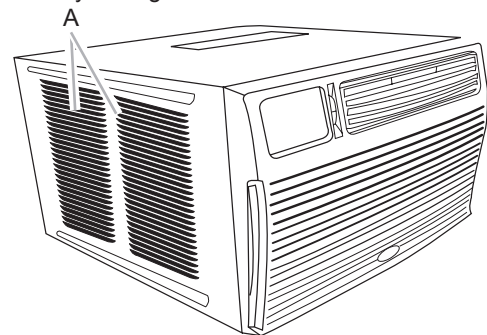

A. Cabinet louvers

### How to install:

Choose a location where there are no any obstacle surrounding the unit, and the plug is accessible. Choose the installation space according to the following diagram.

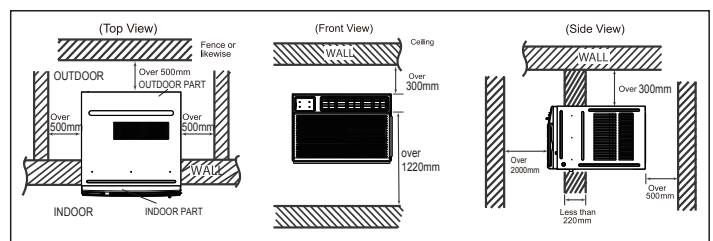

The distance between the air conditioner 300mm and the around obstacles should meet the requirement as below:  
 over 300mm(upper side), over 1220mm(downside),  
 over 500mm(left side), over 500mm(right side),  
 over 2000mm(front side) and over 500mm(rear side).

## Window installation

Window opening measurements:

- 27" min. to 39" max. opening width.
- 16¼" min. opening height.

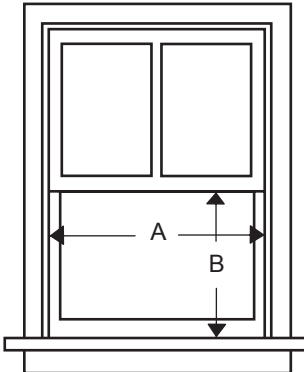

A. 27" min.  
B. 16¼" min.

## Electrical Requirements

### ⚠ WARNING



#### Electrical Shock Hazard

**Plug into a grounded 3 prong outlet.**

**Do not remove ground prong.**

**Do not use an adapter.**

**Do not use an extension cord.**

**Failure to follow these instructions can result in death, fire, or electrical shock.**

Ground wire must be connected to ground screw located in lower right corner of air conditioner when air conditioner is in cabinet.

The electrical ratings for your air conditioner are listed on the model and serial number label. The model and serial number label is located behind the front panel on the flange below the control panel area.

Specific electrical requirements are listed in the chart below. Follow the requirements for the type of plug on the power supply cord.

#### Power supply cord

#### Wiring requirements



- 115-volt (103.5 min. - 126.5 max.)
- 0-12 amps
- 15-amp time-delay fuse or circuit breaker
- Use on single outlet circuit only.

¼"  
(0.6 cm)

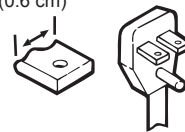

- 230-volt (207 min. - 253 max.)
- 0-12 amps
- 15-amp time-delay fuse or circuit breaker
- Use on single outlet circuit only.

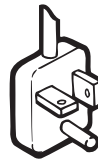

- 208/230-volt (198min. - 253 max.)
- 0-16 amps
- 20-amp time-delay fuse or circuit breaker
- Use on single outlet circuit only.

½"  
(1.3 cm)

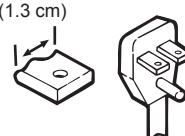

- 230-volt (207 min. - 253 max.)
- 0-24 amps
- 30-amp time-delay fuse or circuit breaker
- Use on single outlet circuit only.

---

## Recommended grounding method

---

This air conditioner must be grounded. This air conditioner is equipped with a power supply cord having a grounded 3 prong plug. To minimize possible shock hazard, the cord must be plugged into a mating, grounded 3 prong outlet, grounded in accordance with all local codes and ordinances. If a mating outlet is not available, it is the customer's responsibility to have a properly grounded 3 prong outlet installed by a qualified electrical installer.

It is the customer's responsibility:

- To contact a qualified electrical installer.
- To assure that the electrical installation is adequate and in conformance with National Electrical Code, ANSI/NFPA 70 - latest edition, and all local codes and ordinances.

Copies of the standards listed may be obtained from:

National Fire Protection Association  
One Batterymarch Park  
Quincy, MA 02269

---

## Power Supply Cord

---

**NOTICE:** Your unit's device may differ from the ones shown.

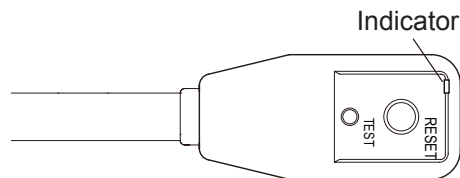

This room air conditioner is equipped with a power supply cord required by UL. This power supply cord contains state-of-the-art electronics that sense leakage current. If the cord is crushed, the electronics detect leakage current and power will be disconnected in a fraction of a second.

## ⚠ WARNING



### Electrical Shock Hazard

Plug into a grounded 3 prong outlet.

Do not remove ground prong.

Do not use an adapter.

Do not use an extension cord.

Failure to follow these instructions can result in death, fire, or electrical shock.

To test your power supply cord:

1. Plug power supply cord into a grounded 3 prong outlet.
2. Press RESET.
3. Press TEST (listen for click; Reset button will trip and pop out).
4. Press and release RESET (listen for click; Reset button will latch and remain in). The power supply cord is ready for operation.

### **NOTICE:**

- The Reset button must be pushed in for proper operation.
- The power supply cord must be replaced if it fails to trip when the test button is pressed or fails to reset.
- Do not use the power supply cord as an off/on switch. The power supply cord is designed as a protective device.
- A damaged power supply cord must be replaced with a new power supply cord obtained from the product manufacturer and must not be repaired.
- The power supply cord contains no user serviceable parts. Opening the tamper-resistant case voids all warranty and performance claims.

# INSTALLATION INSTRUCTIONS

## Unpacking

### **! WARNING**

#### **Excessive Weight Hazard**

**Use two or more people to move and install air conditioner.**

**Failure to do so can result in back or other injury.**

### Remove packaging materials

- Remove and dispose of/recycle all packaging materials. Remove tape and glue residue from surfaces before turning on the air conditioner. Rub a small amount of liquid dish soap over the adhesive with your fingers. Wipe with warm water and dry.
  - Do not use sharp instruments, rubbing alcohol, flammable fluids, or abrasive cleaners to remove tape or glue. These products can damage the surface of your air conditioner.
  - Handle air conditioner gently.
1. Remove air conditioner from carton and place it on cardboard.
  2. Remove shipping screws from both sides of cabinet.

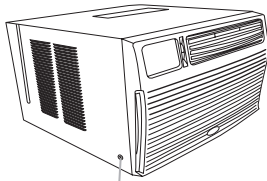

A. Shipping screw

3. Remove front panel by removed 2 phillips screws on both bottom left right sides of front.  
3A: Remove both knobs from control panel.
4. Pull on handle to slide air conditioner out of cabinet. Place air conditioner on cardboard.
5. Remove any paking foam from inside of unit.

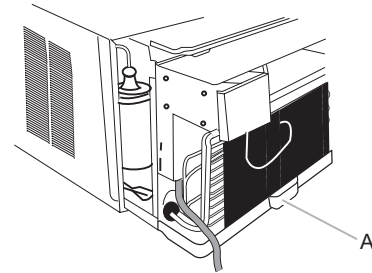

A. Handle

**NOTICE:** Do not lift, push, pull or remove any expanded polystyrene (foam) from inside the air conditioner. It is not packing material.

## Window Installation(on some models)

### **NOTICE:**

- Handle air conditioner gently.
- Be sure your air conditioner cabinet does not fall out of the opening during installation or removal.
- The location where the power cord exits the air conditioner should be no more than 4 ft from a grounded 3 prong outlet.
- Do not block the louvers on the front panel.
- Do not block the louvers on the outside of the air conditioner.

3. Using 3 - #10 x  $\frac{3}{8}$ " pan-head Phillips screws, attach top channel to air conditioner cabinet.

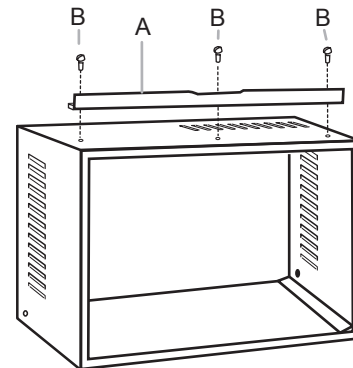

A. Top channel  
B. #10 x  $\frac{3}{8}$ " pan-head Phillips screws (3)

### Attach Top Channel

**NOTICE:** Attach top channel and side curtains to air conditioner cabinet before placing cabinet in window.

1. Locate supplied bag of screws.
2. Place top channel on top of air conditioner cabinet, lining up the 3 holes in top channel with the 3 holes on top of air conditioner cabinet.

## Attach Side Curtains

1. Locate provided bag of screws.
2. Insert top and then bottom of right-hand curtain housing in top and bottom curtain guides on air conditioner cabinet.

### Back View

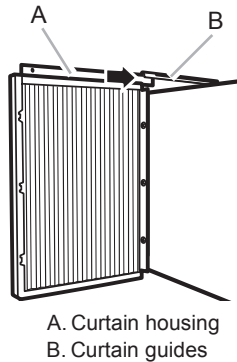

### Bottom View

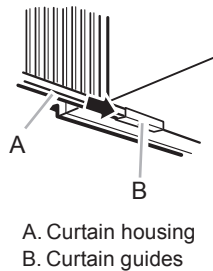

3. Extend right-hand curtain outward so you may insert the first screw through the middle hole of the curtain. Using #10 x 1/4" pan-head Phillips screw, screw curtain to middle hole in air conditioner cabinet.

**NOTICE:** This screw is required to correctly attach curtain (top to bottom) to the air conditioner cabinet.

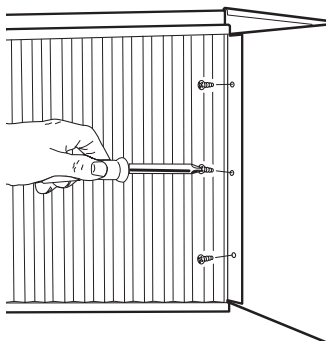

4. While the right-hand curtain is still extended, insert #10 x 1/4" pan-head Phillips screws into the top and bottom slots of curtain. Screw curtain to the top and bottom holes in air conditioner cabinet.
- NOTICE:** Some curtains may have 2 slots at each end. You will be able to see a mounting hole through the correct slot.
5. Slide curtain housing into guides as far as it will go.
6. Repeat above steps for left-hand curtain.

## Attach foam adhesive seal

Attach foam adhesive seal along the bottom of the curtain bottom channel.

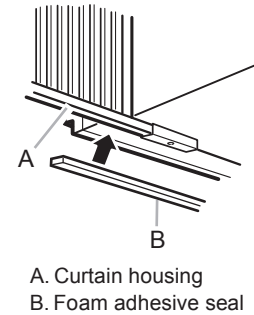

## Install Cabinet into Window

- Handle air conditioner gently.
- Be sure your air conditioner cabinet does not fall out of the opening during installation or removal.
- The location where the power cord exits the air conditioner should be no more than 4 ft from a grounded 3 prong outlet.
- Do not block the louvers on the front panel.
- Do not block the louvers on the outside of the air conditioner.

1. Center empty cabinet in window. Check that lower rail of air conditioner cabinet is behind and against back side of windowsill. Maintain a firm hold on the air conditioner cabinet. Lower window sash to hold cabinet in place. Top channel must be on inside room of window sash.

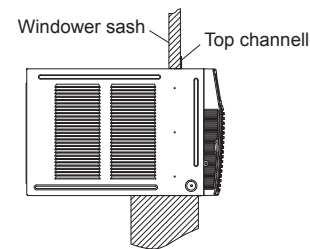

2. Measure the distance between the right-hand side of the cabinet and the inside of the window channel.
3. Repeat for the left side. Adjust the cabinet until the distance on each side is the same.

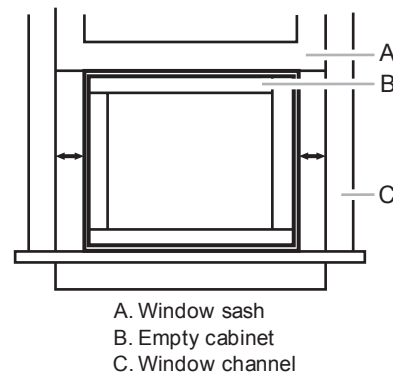

- Use a  $\frac{3}{16}$ " drill bit to drill 3 starter holes  $\frac{1}{2}$ " deep through the 3 holes in the cabinet and into the windowsill.
- Attach cabinet to windowsill with 3 - #10 x  $\frac{1}{2}$ " pan-head Phillips screws.

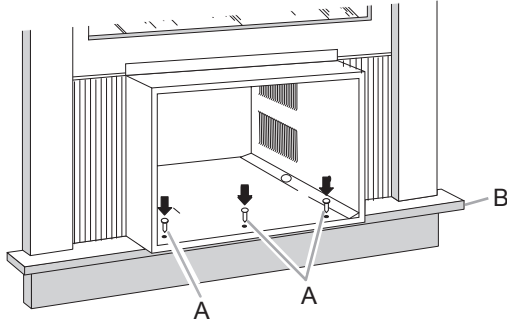

A. #10 x  $\frac{1}{2}$ " pan-head Phillips screws  
B. Windowsill

- Check that air conditioner cabinet is tilted  $\frac{1}{2}$  bubble on carpenter's level to the outside so that water will run to the outside.

### On some models

Select the position that will place the sill supports near the outermost point on the sill. Place the short side of the sill supports, on the case bottom, toward the window. Attach the sill supports to the case track hole in relation to the selected position using 2 Type B screws in each support.

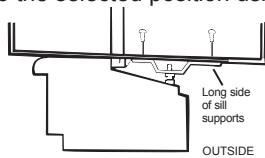

**CAUTION:** Do not install this air conditioner in a window if the bolts do not contact the window sill.

### Attach Side Curtains to Window Frame

- Pull left-hand curtain out until it fits into window channel. Use a  $\frac{3}{32}$ " drill bit to drill a starter hole through the hole in the curtain housing and into the lower window sash.

#### Front View

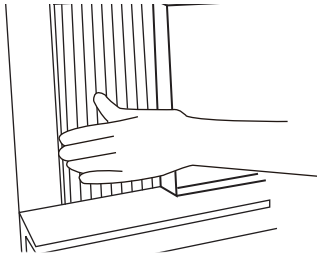

#### Top View

- A. Left-hand curtain  
B. Window channel  
C. #10 x  $\frac{3}{4}$ " round-head screw

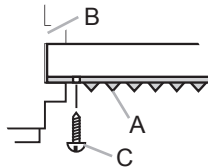

- Insert one of the #10 x  $\frac{3}{4}$ " round-head screws through hole and into lower window sash. Insert one of the #10 x  $\frac{3}{4}$ " round-head screws through threaded hole in top of curtain and one in bottom of curtain .

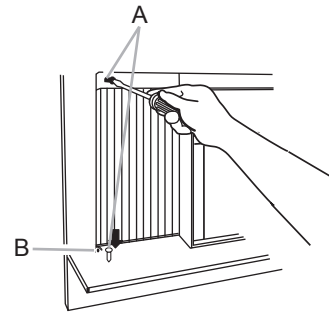

A. #10 x  $\frac{3}{4}$ " round-head screw  
B. Hole for #10 x  $\frac{3}{4}$ " round-head screw

- Repeat for right-hand curtain.

### Complete Window Installation

- Insert foam seal behind the top of the lower window sash and against the glass of the upper window.
- Place window-lock bracket on top of lower window and against upper window sash.
- Use a  $\frac{3}{32}$ " drill bit to drill a starter hole through the hole in the bracket and into the window sash.
- Attach window-lock bracket to window sash with #10 x  $\frac{3}{4}$ " round-head screw to secure window in place.

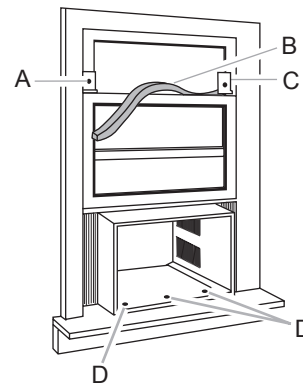

A. Window lock bracket(2) C. Upper window glass  
B. Foam seal D. #10 x  $\frac{1}{2}$ " pan-head Phillips screws (3)

## Complete Installation

**NOTICE:** Handle air conditioner gently.

### **! WARNING**

#### **Excessive Weight Hazard**

**Use two or more people to move and install air conditioner.**

**Failure to do so can result in back or other injury.**

1. Insert air conditioner into cabinet.

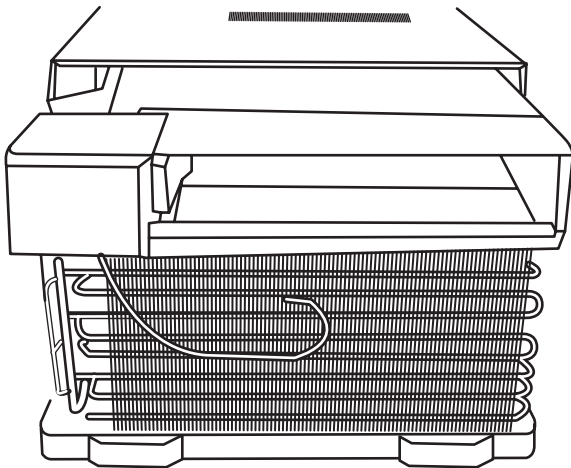

3. Install ground screws on both sides of cabinet .
4. Insert front tabs of front panel into top of cabinet and swing front into place.
5. Attach bottom front of panel with front panel screws. Replace control knobs (on some models).

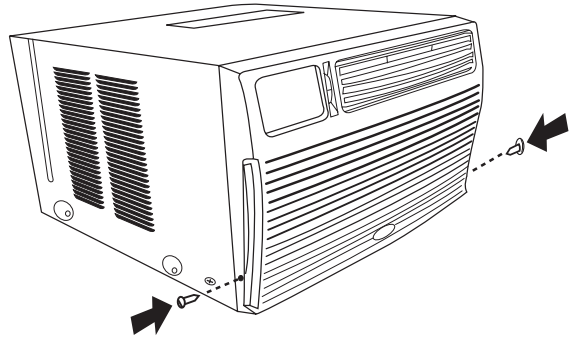

**NOTICE:** For through-the-wall installations, if needed, install molding around room side of cabinet.

### **! WARNING**



#### **Electrical Shock Hazard**

**Plug into a grounded 3 prong outlet.**

**Do not remove ground prong.**

**Do not use an adapter.**

**Do not use an extension cord.**

**Failure to follow these instructions can result in death, fire, or electrical shock.**

### **! WARNING**



#### **Electrical Shock Hazard**

**Install two ground screws on both sides of cabinet.**

**Failure to do so can result in death or electrical shock.**

6. Plug into a grounded 3 prong outlet.
7. Press RESET on the power supply cord plug.

## General Operating Instructions

While operation of all units is similar, controls vary slightly from model to model. Operating Controls section shows control panel of unit purchased and gives detailed information about operation of controls.

### Airflow Around Unit

Select the highest fan speed and set temperature control to its coldest position. When the desired temperature is reached, slowly move the temperature control toward a warmer setting until the compressor shuts off. The thermostat will then cycle the compressor on and off to maintain this selected temperature. Adjust the fan speed for desired air circulation.

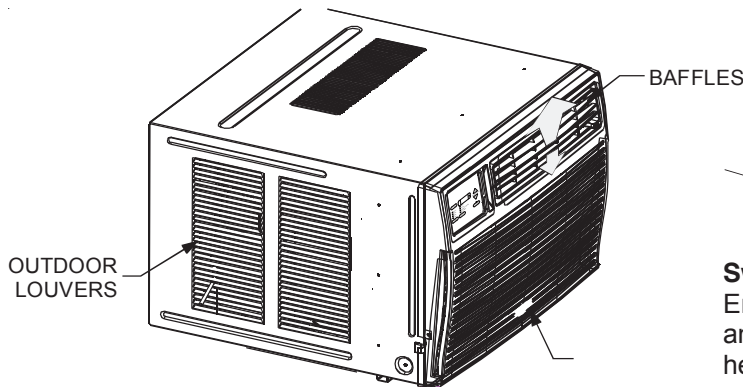

### Changing Airflow Direction Baffles

Airflow on unit may be diverted left or right from center by baffles. Upward and downward air discharge is provided by tilting louvers. Adjust baffles and tilt louvers for desired airflow pattern.

### Airflow Around Unit

Check the indoor grille and outdoor louvers for obstructions to airflow. Do not block the airflow to and from the unit. If air is obstructed and/or deflected back into the unit, the air conditioner's compressor may cycle on and off rapidly. This could damage your unit.

### Drain Cup Installation and Use (on some models)

Your air conditioner uses a system where the water removed from the indoor air (condensate) is channeled to the outdoor side of the unit. The outdoor fan blade has a "slinger" ring attached to it that dips into the water and slings the water onto the outdoor coil surface. This is the sound of water you hear during normal operation. The water quickly evaporates on this warm surface and improves the efficiency of your air conditioner. In normal conditions the unit can evaporate the water as fast as it is removed from the indoor air.

However, in very humid conditions excess amounts of water may drip off the unit chassis. If this proves to be a problem, install the condensate drain cup included with the unit to route excess water where it would not be a problem (see illustration).

To install, remove the unit chassis from the outer case. Insert the condensate drain cup through the recessed  $\frac{1}{2}$ " hole on the back center of the outer case. Once inserted, place a  $\frac{1}{2}$ " diameter hose or tube on the drain cup bottom spout. The hose allows you to route where you want the excess water to go. Reinsert the unit chassis into the outer case. The unit basepan overflow hole will be positioned directly above the drain cup and will catch any water that might run out.

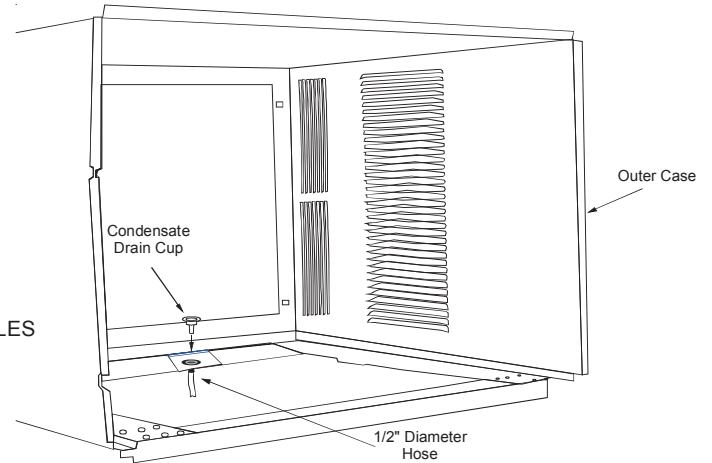

### Switchover Thermostat Control

Emergency heat switch overrides heat pump (compressor) and starts auxiliary electrical heater. When switch is ON, heat pump is locked out.

- Use emergency switch only when heat pump fails to provide adequate heat. Cause of heat pump malfunction should be determined by authorized servicer. Cost of operating unit will increase when emergency heat switch is engaged.

### Only for Qualified Service Personnel

To access and engage emergency switch:

- Unplug unit.
- 1. Remove front grille, air filter, and plastic front, as described in Installation Instructions.
- 2. Slide chassis out of case about two inches.
- 3. Locate access hole for emergency switch above label on right front of control box.
- 4. Remove control panel for access.
- 5. Remove outdoor thermostat from control box and locate "flat head" adjustment screw on back of thermostat.
- 6. To start emergency heat, insert flathead screwdriver into slot and turn counterclockwise until switch-stop is reached.
- 7. Return chassis to case.
- 8. Re-install thermostat and mount control panel door.
- 9. Replace plastic front, air filter, and front grille.

## Operating Controls(For Electronic units)

Operating your air conditioner properly helps you to obtain the best possible results.

This section explains proper air conditioner operation.

### IMPORTANT:

- If you turn off the air conditioner, wait at least 3 minutes before turning it back on. This prevents the air conditioner from blowing a fuse or tripping a circuit breaker.
- Do not try to operate your air conditioner in the cooling mode when outside temperature is below 61°F (16°C). Do not try to operate your air conditioner in the heating mode when outside temperature is over 86°F (30°C). The inside evaporator coil will freeze up, and the air conditioner will operate properly.

**NOTICE:** In the event of a power failure, your air conditioner will operate at the previous settings when the power is restored.

Lights next to the touch pads on the air conditioner control panel indicate the selected settings.

The display shows the set temperature when in Heat/Cool/Energy Saver mode. Shows time remaining on the delay timer. Shows the room temperature when in Fan Only mode.

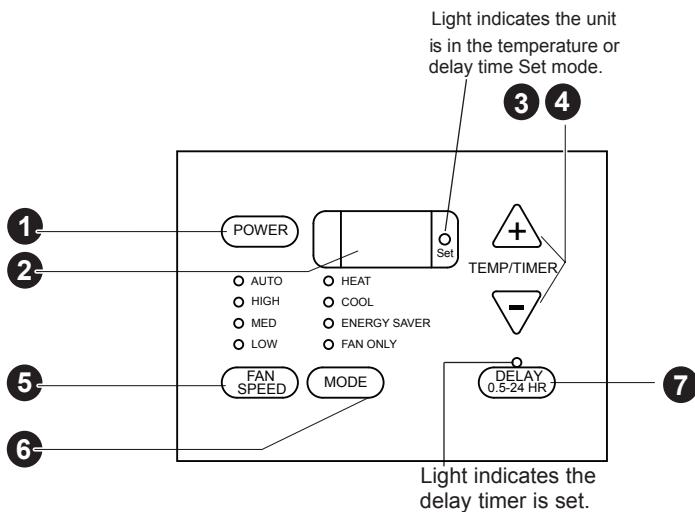

## Air Conditioner Controls

### Controls

- 1 Power Pad**  
Turns air conditioner on and off.

- 2 Display**  
Shows the set temperature when in Heat/Cool/Energy Saver mode. Shows time remaining on the delay timer. Shows the room temperature when in Fan Only mode. The Set light will turn on while setting.

- 3 Temp Increase▲/Decrease▼Pads**  
Use to set temperature when in Heat (on some models)/Cool/Energy Saver. The **Set** light will turn on while setting. Press **Increase(+)** and **Decrease(-)** Pads at the same time for 3 seconds, Temperature display will change between °F and °C.

- 4 Delay Timer Increase ▲ (+) / Decrease ▼ (-) Pads**  
Each touch of the **Increase▲ / Decrease▼** pads on the unit will set the delay time when using the **Delay 0.5–24hr** timer (⌚). The **Set** light will turn on while setting.

- 5 Fan Speed Pads**  
Use to set the fan speed to **Low, Med, High** or **Auto** on the unit.

- 6 Mode Pad**  
Use to set the air conditioner to **Cool, Energy Saver, Fan Only** or **Heat** (on some models) mode.

- 7 Delay Pads**  
**Delay ON**—When the air conditioner is off, it can be set to automatically come on in 0.5 to 24 hours at its previous mode and fan settings.

**Delay OFF**—When the air conditioner is on, it can be sent to automatically turn off in 0.5 to 24 hours.

#### How to set:

Press the **Delay 0.5–24hr** pad on the unit or the ⌚ pad on the remote control. Each touch of the **Increase▲ / Decrease▼** pads on the unit will set the timer in 0.5 hour or 1 hour intervals (the intervals is 0.5 hour as the delay timer below 10 hours; the intervals is 1 hour as the delay timer above 10 hours). The **Set** light will turn on while setting.

To review the remaining time on the **Delay 0.5-24hr** timer, press the **Delay 0.5-24hr** pad on the unit. Use the **Increase▲ / Decrease▼** pads on the unit to set a new time if desired.

**To cancel the timer,** press the **Delay 0.5-24hr** and until the light on the **Delay 0.5-24hr** and goes off.

## Buttons on remote controller

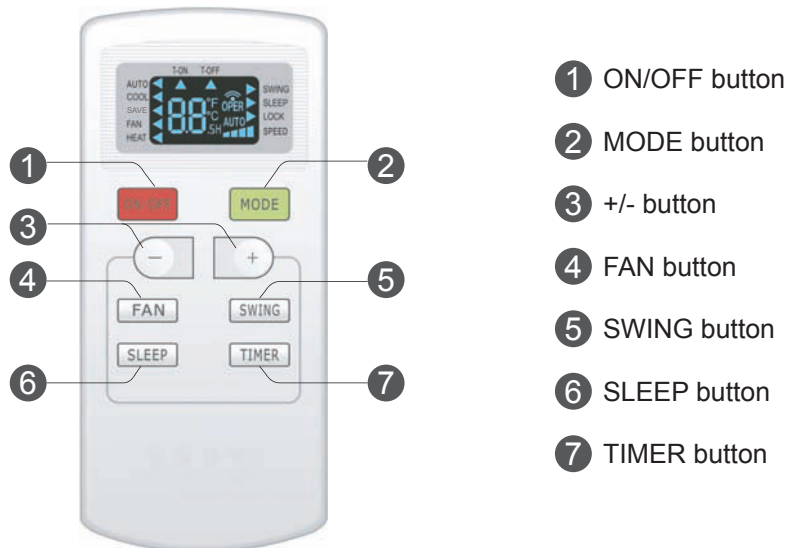

- ① ON/OFF button
- ② MODE button
- ③ +/- button
- ④ FAN button
- ⑤ SWING button
- ⑥ SLEEP button
- ⑦ TIMER button

## Introduction for icons on display screen

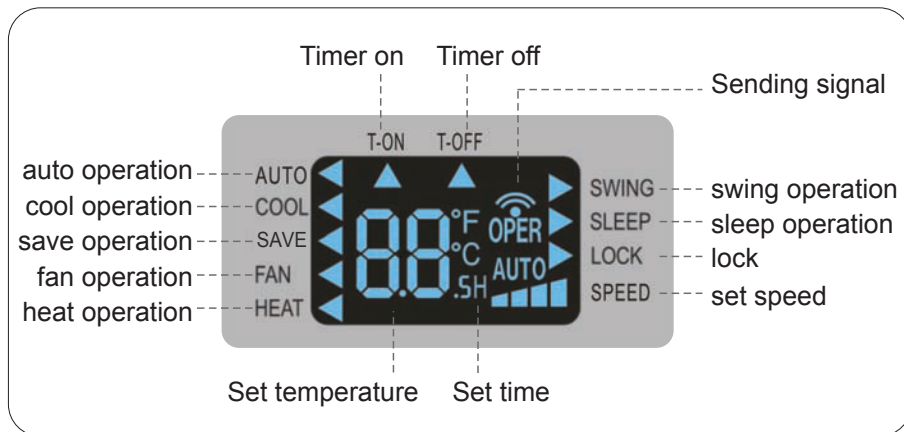

## Introduction for buttons on remote controller

### NOTICE:

This is a general use remote controller, it could be used for the air conditioners with multifunction; For some function, which the model doesn't have, if press the corresponding button on the remote controller that the unit will keep the original running status.

When power is connected(stand by condition), you can operate the air conditioner through the remote controller.

When unit is on, each time you press the button on remote controller, the sending signal icon "📶" on the display of remote controller will blink once. If the air conditioner gives out a beep sound, it means the signal has been sent.

When unit is off, set temperature will be displayed on the remote controller (If the light of indoor unit display is turned on, the corresponding icon will be displayed); When unit is on, it will display the icon of the on-going function.

### 1 ON/OFF button

Press this button to turn unit on/off.

### 2 MODE button

Pressing this button once can select your required mode circularly as below (the corresponding icon "◀" will be lit up after the mode is selected):



- When selecting auto mode, air conditioner will operate automatically according to ambient temperature. Set temperature can't be adjusted and won't be displayed either. Press FAN button to adjust fan speed. (The auto mode is not available for this model.)
- When selecting cool mode, air conditioner will operate under cool mode. Then press + or - button to adjust set temperature. Press FAN button to adjust fan speed.
- When selecting save mode, air conditioner will operate under save mode.
- When selecting fan mode, air conditioner will operate in fan mode only. Then press FAN button to adjust fan speed.
- When selecting heat mode, air conditioner will operate under heat mode. Then press + or - button to adjust set temperature. Press FAN button to adjust fan speed. (Cooling only unit can't receive heating mode signal. If set HEAT mode by remote controller, press ON/OFF button can't turn on the air conditioner.)

### 3 + / - button

- Pressing + or - button once will increase or decrease set temperature by 1°F(°C). Hold + or - button for 2s, set temperature on remote controller will change quickly. Release the button after your required set temperature is reached.
- When setting Timer On or Timer Off, press + or - button to adjust the time. (See TIMER Button for setting details)

### 4 FAN button

Pressing this button can select fan speed circularly as: AUTO, SPEED 1 (▲), SPEED 2 (▲▲), SPEED 3 (▲▲▲), SPEED 4 (▲▲▲▲).

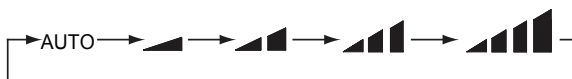

#### **NOTICE:**

- Under Auto speed, air conditioner will select proper fan speed automatically according to ambient temperature.
- There are 3 speeds for the Fan Speed of this model.

### 5 SWING button

Press this button to turn on left&right air swing.

Notice: Swing operation only designed for 18K models, if press the swing operation button on the remote controller, the 9K,12K unit will keep the original running status.

### 6 SLEEP button

Under Cool, Heat mode, press this button to turn on Sleep function. Press this button to cancel Sleep function. Under Fan and Auto mode, this function is unavailable.

### 7 TIMER button

- When unit is on, press this button to set Timer Off. T-OFF and H icon will be blinking. Within 5s, press + or - button to adjust the time for Timer Off. Pressing + or - button once will increase or decrease the time by 0.5h. Hold + or - button for 2s, time will change quickly. Release the button after your required set time is reached. Then press TIMER button to confirm it. T-OFF and H icon will stop blinking.
- When unit is off, press this button to set Timer On. T-ON and H icon will be blinking. Within 5s, press + or - button to adjust the time for Timer On. Pressing + or - button once will increase or decrease the time by 0.5h. Hold + or - button for 2s, time will change quickly. Release the button after your required set time is reached. Then press TIMER button to confirm it. T-ON and H icon will stop blinking.
- Cancel Timer On/Off: If Timer function is set up, press TIMER button once to review the remaining time. Within 5s, press TIMER button again to cancel this function.

#### **NOTICE:**

- Range of time setting is: 0.5~24h
- The interval between two motions can't exceed 5s, otherwise the remote controller will exit setting status.

## Function introduction for combination buttons

### Child lock function

Press "+" and "-" buttons simultaneously can turn on or turn off child lock function. When child lock function is started up, LOCK indicator on remote controller is ON. If you operate the remote controller, remote controller won't send signal.

### Temperature display switchover function

Under OFF status, press "-" button and "MODE" button simultaneously can switch between °C and °F.

## Operation guide

1. After putting through the power, press "ON/OFF" button on remote controller to turn on the air conditioner.
2. Press "MODE" button to select your required mode: AUTO, COOL, SAVE, FAN, HEAT.
3. Press "+" or "-" button to set your required temperature. (Temperature can't be adjusted under auto mode).
4. Press "FAN" button to set your required fan speed: auto, low, medium and high speed.
5. Press "SWING" button to select fan blowing angle.

## Replacement of batteries in remote controller

1. Press the back side of remote controller on the spot marked with "", and then push out the cover of battery box along the arrow direction.
2. Replace two No.7 (AAA 1.5V) dry batteries and make sure the positions of + and- polar are correct.
3. Reinstall the cover of battery box.

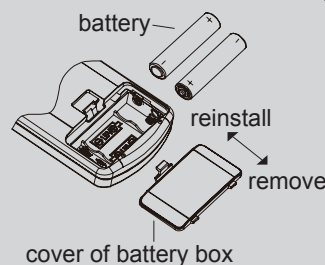

### NOTICE

- During operation, point the remote control signal sender at the receiving window on indoor unit.
- The distance between signal sender and receiving window should be no more than 8m, and there should be no obstacles between them.
- Signal may be interfered easily in the room where there is fluorescent lamp or wireless telephone; remote controller should be close to indoor unit during operation.
- Replace new batteries of the same model when replacement is required.
- When you don't use remote controller for a long time, please take out the batteries.
- If the display on remote controller is fuzzy or there's no display, please replace batteries.



## Before Calling Service



### WARNING

**To reduce the risk of electric shock, personal injury, or death, turn the fan control to the off position and remove the unit plug from the wall outlet before doing any inspection or maintenance work.**

The following is a list of problems that are sometimes encountered when using a room air conditioner. Possible cause and suggested remedies are given for each problem.

If the problem cannot be fixed using the suggested remedies, see WHEN SERVICE IS REQUIRED section.

PROBLEM	POSSIBLE CAUSE	SUGGESTED REMEDY
UNIT WILL NOT RUN	No power to unit	Push reset button on power cord. Set Fan Control to position other than OFF. Make sure plug is firmly seated in outlet. Check for blown fuses, tripped circuit breakers.
LITTLE OR NO COOLING LITTLE OR NO HEATING (fan and compressor run)	Fresh air/exhaust damper open Obstructed indoor or outdoor airflow Dirty air filters Unit undersized for application	Set vent to CLOSED. Remove obstruction from indoor grille or outdoor louvers. Dirty air filter. Clean or replace, as needed. Check with dealer to determine proper capacity unit for application.
LITTLE OR NO COOLING LITTLE OR NO HEATING (only fan runs)	Temperature Control not set properly	For cooling, turn Temperature Control to cooler setting. For heating, turn Temperature Control to warmer setting.
NOISY UNIT	Loose front on mounting assembly Weak building construction Water hitting fan blade Unit oversized for application: compressor cycles on and off frequently	Tighten any loose parts. Provide additional support for unit. Normal in high humidity. Stop noise by removing drain plug or adding condensate drain cup. Check with dealer to determine proper capacity unit for application.
MOUNTING SUPPORT NOT INSTALLED	Storm window frame installed in window	Some models require removal of storm window frame before installation.
FROST ON INDOOR COIL	Dirty air filter Normal for low outdoor temperatures	Clean air filter by vacuuming or washing with water and mild soap. Turning Temperature Control to warmer setting reduces occurrence and duration of frost.
FROST ON OUTDOOR COIL (heat pump models only)	Normal for outdoor temperatures at or below 45°F	Call for service only if unit does not heat room and you have checked all problems and remedies listed under LITTLE OR NO HEATING.
ODORS IN COOLING	Mold, mildew, or algae formation on wet surfaces	To reduce algae growth, use algacide tablet in base pan; remove drain plug; add condensate drain cup and hose. Thoroughly clean unit.
ODORS IN HEATING	Normal for first time electric heater is used each season	Caused by dust accumulation during unused months. Odor dissipates quickly with heater use.

### When Service Is Required

Your room air conditioner dealer can give you the name of your nearest Authorized Service Center. Help them give you prompt service by providing:

- An accurate description of problem.
- Complete model, serial, and manufacturing (P) numbers from serial plate.
- Proof of purchase (sales receipt) upon request.

Repair by unauthorized servicer that results in subsequent failure of unit voids warranty. Warranty details are contained in warranty certificate enclosed with unit.

Keep accurate records of service calls, including what was done, servicer's name, and date of service.

### Any Questions?

Most questions can be answered by your local dealer. If you have other matters that cannot be resolved locally, or you need additional information regarding other heating and cooling products offered by us - please call:

#### CONSUMER INFORMATION LINE

**Tel: (86-756) 8617555 (Customer Service Center)**

**Web Site: <http://www.gree.com.cn>**

# Specialist's manual

## Aptitude requirement for maintenance man(repairs should be done only be specialists).

- a. Any person who is involved with working on or breaking into a refrigerant circuit should hold a current valid certificate from an industry-accredited assessment authority, which authorises their competence to handle refrigerants safely in accordance with an industry recognised assessment specification.
- b. Servicing shall only be performed as recommended by the equipment manufacturer. Maintenance and repair requiring the assistance of other skilled personnel shall be carried out under the supervision of the person competent in the use of flammable refrigerants.

## Safety preparation work

The maximum refrigerant charge amount is shown on the following table a.

(Note: Please refer to the nameplate for the charging quantity of R32).

Minimum room area (m <sup>2</sup> )	Charge amount (kg)	Room area (m <sup>2</sup> )														
		0.92	1.3	1.4	1.5	1.6	1.7	1.8	1.9	2	2.1	2.2	2.3	2.4	2.5	
Minimum room area (m <sup>2</sup> )	floor location	/	14.5	16.8	19.3	22	24.8	27.8	31	34.3	37.8	41.5	45.4	49.4	53.6	
	window mounted	/	5.2	6.1	7	7.9	8.9	10	11.2	12.4	13.6	15	16.3	17.8	19.3	
	ceiling mounted	/	1.1	1.3	1.4	1.6	1.8	2.1	2.3	2.6	2.8	3.1	3.4	3.7	4	

table a - Maximum charge (kg)

Prior to beginning work on systems containing flammable refrigerants, safety checks are necessary to ensure that the risk of ignition is minimised. For repair to the refrigerating system, the following precautions shall be complied with prior to conducting work on the system.

### • Work procedure

Work shall be undertaken under a controlled procedure so as to minimise the risk of a flammable gas or vapour being present while the work is being performed.

### • General work area

All maintenance staff and others working in the local area shall be instructed on the nature of work being carried out. Work in confined spaces shall be avoided. The area around the workspace shall be sectioned off. Ensure that the conditions within the area have been made safe by control of flammable material

### • Checking for presence of refrigerant

The area shall be checked with an appropriate refrigerant detector prior to and during work, to ensure the technician is aware of potentially toxic or flammable atmospheres. Ensure that the leak detection equipment being used is suitable for use with all applicable refrigerants, i.e. non-sparking, adequately sealed or intrinsically safe.

### • Presence of fire extinguisher

If any hot work is to be conducted on the refrigeration equipment or any associated parts, appropriate fire extinguishing equipment shall be available to hand. Have a dry powder or CO<sub>2</sub> fire extinguisher adjacent to the charging area.

### • No ignition sources

No person carrying out work in relation to a refrigeration system which involves exposing any pipe work shall use any sources of ignition in such a manner that it may lead to the risk of fire or explosion. All possible ignition sources, including cigarette smoking, should be kept sufficiently far away from the site of installation, repairing, removing and disposal, during which refrigerant can possibly be released to the surrounding space. Prior to work taking place, the area around the equipment is to be surveyed to make sure that there are no flammable hazards or ignition risks. "No Smoking" signs shall be displayed.

### • Ventilated area

Ensure that the area is in the open or that it is adequately ventilated before breaking into the system or conducting any hot work. A degree of ventilation shall continue during the period that the work is carried out. The ventilation should safely disperse any released refrigerant and preferably expel it externally into the atmosphere.

### • Checks to the refrigeration equipment

Where electrical components are being changed, they shall be fit for the purpose and to the correct specification. At all times the manufacturer's maintenance and service guidelines shall be followed. If in doubt, consult the manufacturer's technical department for assistance.

The following checks shall be applied to installations using flammable refrigerants:

- The actual refrigerant charge is in accordance with the room size within which the refrigerant containing parts are installed;
- The ventilation machinery and outlets are operating adequately and are not obstructed;
- If an indirect refrigerating circuit is being used, the secondary circuit shall be checked for the presence of refrigerant;
- Marking to the equipment continues to be visible and legible. Markings and signs that are illegible shall be corrected;
- Refrigeration pipe or components are installed in a position where they are unlikely to be exposed to any substance which may corrode refrigerant containing components, unless the components

## Specialist's manual

are constructed of materials which are inherently resistant to being corroded or are suitably protected against being so corroded.

- Checks to electrical devices

Repair and maintenance to electrical components shall include initial safety checks and component inspection procedures. If a fault exists that could compromise safety, then no electrical supply shall be connected to the circuit until it is satisfactorily dealt with. If the fault cannot be corrected immediately but it is necessary to continue operation, an adequate temporary solution shall be used. This shall be reported to the owner of the equipment so all parties are advised.

Initial safety checks shall include:

- That capacitors are discharged: this shall be done in a safe manner to avoid possibility of sparking;
- That no live electrical components and wiring are exposed while charging, recovering or purging the system;
- That there is continuity of earth bonding.

### Repairs to sealed components

During repairs to sealed components, all electrical supplies shall be disconnected from the equipment being worked upon prior to any removal of sealed covers, etc. If it is absolutely necessary to have an electrical supply to equipment during servicing, then a permanently operating form of leak detection shall be located at the most critical point to warn of a potentially hazardous situation.

Particular attention shall be paid to the following to ensure that by working on electrical components, the casing is not altered in such a way that the level of protection is affected. This shall include damage to cables, excessive number of connections, terminals not made to original specification, damage to seals, incorrect fitting of glands, etc.

- Ensure that the apparatus is mounted securely.
- Ensure that seals or sealing materials have not degraded to the point that they no longer serve the purpose of preventing the ingress of flammable atmospheres. Replacement parts shall be in accordance with the manufacturer's specifications.

### Repair to intrinsically safe components

Do not apply any permanent inductive or capacitance loads to the circuit without ensuring that this will not exceed the permissible voltage and current permitted for the equipment in use.

Intrinsically safe components are the only types that can be worked on while live in the presence of a flammable atmosphere. The test apparatus shall be at the correct rating.

Replace components only with parts specified by the manufacturer. Other parts may result in the ignition of refrigerant in the atmosphere from a leak.

Note :

The use of silicon sealant can inhibit the effectiveness of some types of leak detection equipment. Intrinsically safe components do not have to be isolated prior to working on them.

### Cabling

Check that cabling will not be subject to wear, corrosion, excessive pressure, vibration, sharp edges or any other adverse environmental effects. The check shall also take into account the effects of aging or continual vibration from sources such as compressors or fans.

### Detection of flammable refrigerants

Under no circumstances shall potential sources of ignition be used in the searching for or detection of refrigerant leaks. A halide torch (or any other detector using a naked flame) shall not be used.

The following leak detection methods are deemed acceptable for all refrigerant systems.

Electronic leak detectors may be used to detect refrigerant leaks but, in the case of FLAMMABLE REFRIGERANTS, the sensitivity may not be adequate, or may need re-calibration. (Detection equipment shall be calibrated in a refrigerant-free area.) Ensure that the detector is not a potential source of ignition and is suitable for the refrigerant used. Leak detection equipment shall be set at a percentage of the LFL of the refrigerant and shall be calibrated to the refrigerant employed, and the appropriate percentage of gas (25 % maximum) is confirmed.

Leak detection fluids are also suitable for use with most refrigerants but the use of detergents containing chlorine shall be avoided as the chlorine may react with the refrigerant and corrode the copper pipe-work.

- NOTE Examples of leak detection fluids are
- bubble method,
  - fluorescent method agents.

If a leak is suspected, all naked flames shall be removed/extinguished.

If a leakage of refrigerant is found which requires brazing, all of the refrigerant shall be recovered from the system, or isolated (by means of shut off valves) in a part of the system remote from the leak. Removal of refrigerant shall be according to Clause Removal and evacuation.

### Removal and evacuation

When breaking into the refrigerant circuit to make repairs – or for any other purpose –conventional procedures shall be used. However, for flammable refrigerants it is important that best practice be

## Specialist's manual

followed, since flammability is a consideration. The following procedure shall be adhered to:

- a) safely remove refrigerant following local and national regulations;
- b) purge the circuit with inert gas;
- c) evacuate (optional for A2L);
- d) purge with inert gas (optional for A2L);
- e) open the circuit by cutting or brazing.

The refrigerant charge shall be recovered into the correct recovery cylinders if venting is not allowed by local and national codes. For appliances containing flammable refrigerants, the system shall be purged with oxygen-free nitrogen to render the appliance safe for flammable refrigerants. This process might need to be repeated several times. Compressed air or oxygen shall not be used for purging refrigerant systems.

For appliances containing flammable refrigerants, refrigerants purging shall be achieved by breaking the vacuum in the system with oxygen-free nitrogen and continuing to fill until the working pressure is achieved, then venting to atmosphere, and finally pulling down to a vacuum (optional for A2L). This process shall be repeated until no refrigerant is within the system (optional for A2L). When the final oxygen-free nitrogen charge is used, the system shall be vented down to atmospheric pressure to enable work to take place.

Ensure that the outlet for the vacuum pump is not close to any potential ignition sources and that ventilation is available.

### Charging procedures

In addition to conventional charging procedures, the following requirements shall be followed.

- Ensure that contamination of different refrigerants does not occur when using charging equipment. Hoses or lines shall be as short as possible to minimise the amount of refrigerant contained in them.
- Cylinders shall be kept in an appropriate position according to the instructions.
- Ensure that the refrigeration system is earthed prior to charging the system with refrigerant.
- Label the system when charging is complete (if not already).
- Extreme care shall be taken not to overfill the refrigeration system.

Prior to recharging the system, it shall be pressure-tested with the appropriate purging gas.

The system shall be leak-tested on completion of charging but prior to commissioning. A follow up leak test shall be carried out prior to leaving the site.

### Decommissioning

Before carrying out this procedure, it is essential that

the technician is completely familiar with the equipment and all its detail. It is recommended good practice that all refrigerants are recovered safely. Prior to the task being carried out, an oil and refrigerant sample shall be taken in case analysis is required prior to reuse of reclaimed refrigerant. It is essential that electrical power is available before the task is commenced.

- a) Become familiar with the equipment and its operation.
- b) Isolate system electrically.
- c) Before attempting the procedure, ensure that:
  - mechanical handling equipment is available, if required, for handling refrigerant cylinders;
  - all personal protective equipment is available and being used correctly;
  - the recovery process is supervised at all times by a competent person;
  - recovery equipment and cylinders conform to the appropriate standards.
- d) Pump down refrigerant system, if possible.
- e) If a vacuum is not possible, make a manifold so that refrigerant can be removed from various parts of the system.
- f) Make sure that cylinder is situated on the scales before recovery takes place.
- g) Start the recovery machine and operate in accordance with manufacturer's instructions.
- h) Do not overfill cylinders. (No more than 80 % volume liquid charge).
- i) Do not exceed the maximum working pressure of the cylinder, even temporarily.
- j) When the cylinders have been filled correctly and the process completed, make sure that the cylinders and the equipment are removed from site promptly and all isolation valves on the equipment are closed off.
- k) Recovered refrigerant shall not be charged into another refrigeration system unless it has been cleaned and checked.

### Labelling

Equipment shall be labelled stating that it has been decommissioned and emptied of refrigerant. The label shall be dated and signed. For appliances containing flammable refrigerants, ensure that there are labels on the equipment stating the equipment contains flammable refrigerant.

### Recovery

When removing refrigerant from a system, either for servicing or decommissioning, it is recommended good practice that all refrigerants are removed safely.

When transferring refrigerant into cylinders, ensure

that only appropriate refrigerant recovery cylinders are employed. Ensure that the correct number of cylinders for holding the total system charge are available. All cylinders to be used are designated for the recovered refrigerant and labelled for that refrigerant (i.e. special cylinders for the recovery of refrigerant). Cylinders shall be complete with pressure-relief valve and associated shut-off valves in good working order. Empty recovery cylinders are evacuated and, if possible, cooled before recovery occurs.

The recovery equipment shall be in good working order with a set of instructions concerning the equipment that is at hand and shall be suitable for the recovery of all appropriate refrigerants including, when applicable, flammable refrigerants. In addition, a set of calibrated weighing scales shall be available and in good working order. Hoses shall be complete with leak-free disconnect couplings and in good condition. Before using the recovery machine, check that it is in satisfactory working order, has been properly maintained and that any associated electrical components are sealed to prevent ignition in the event of a refrigerant release. Consult manufacturer if in doubt.

The recovered refrigerant shall be returned to the refrigerant supplier in the correct recovery cylinder, and the relevant waste transfer note arranged. Do not mix refrigerants in recovery units and especially not in cylinders.

If compressors or compressor oils are to be removed, ensure that they have been evacuated to an acceptable level to make certain that flammable refrigerant does not remain within the lubricant. The evacuation process shall be carried out prior to returning the compressor to the suppliers. Only electric heating to the compressor body shall be employed to accelerate this process. When oil is drained from a system, it shall be carried out safely.



## LIMITED EXPRESS WARRANTY

Congratulations on purchasing your new HVAC equipment. It's been designed for long life and reliable service, and is backed by one of the strongest warranties in the industry. Your unit automatically qualifies for the warranty coverage listed below, providing you keep your proof of purchase (receipt) for the equipment and meet the warranty conditions.

### LIMITED ONE (1) YEAR EXPRESS WARRANTY

Comfort-Aire warrants this Room Air Conditioner to be free from defects in workmanship and materials for normal use and maintenance for one (1) year from the date of purchase by the original consumer. This Express Limited Warranty applies only when the Room Air Conditioner is installed and operated per Comfort-Aire installation and operating instructions for normal use.

### EXCEPTIONS

The Limited Express Warranty does not cover normal maintenance. Comfort-Aire recommends that regular inspection/maintenance be performed at least once a season. Additionally, labor charges, diagnostic charges, transportation charges for replacement of refrigerant or filters, and any other service calls/repairs are not covered by this Limited Warranty. It also does not cover any portion or component of the system that is not supplied by Comfort-Aire, regardless of the cause of failure of such portion or component.

### CONDITIONS FOR WARRANTY COVERAGE

Unit must be operated according to Comfort-Aire operating instructions included with the unit and cannot have been subjected to accident, alteration, improper repair, neglect or misuse, or an act of God (such as a flood)

- Serial numbers and/or rating plate have not been altered or removed
- Performance cannot be impaired by use of any product not authorized by Comfort-Aire, or by any adjustments or adaptations to components
- Damage has not been a result of inadequate wiring or voltage conditions, use during brown-out conditions, or circuit interruptions
- Air flow around any section of the unit has not been restricted
- Unit remains in the original installation

### DURATION OF WARRANTY & REGISTRATION

The warranty begins on the date of purchase by the original consumer. The consumer must retain a receipted bill of sale as proof of warranty period. Without this proof, the express warranty begins on the date of shipment from the factory.

### REMEDY PROVIDED BY THE LIMITED EXPRESS WARRANTY

The sole remedy under the Limited Warranty is replacement of the defective unit. Labor to diagnose and replace the defective unit is not covered by this Limited Express Warranty. If for any reason the replacement product is no longer available during the warranty period, Comfort-Aire shall have the right to allow a credit in the amount of the current suggested retail price of the product instead of providing replacement.

### LIMITATION OF LIABILITY

1. There are no other express or implied warranties. Comfort-Aire makes no warranty of merchantability. We do not warrant that the unit is suitable for any particular purpose or can be used in buildings or rooms of any particular size or condition except as specifically provided in this document. There are no other warranties, express or implied, which extend beyond the description in this document.
2. All warranties implied by law are limited in duration to the one-term of the warranty. **We will not be liable for any consequential or incidental damages caused by any defect in this unit.**
3. This warranty gives you specific legal rights and you may also have other rights which vary from state to state. Some states do not allow limitation on how long an implied warranty lasts or do not allow the exclusion or limitation of incidental or consequential damages, so the above limitations or exclusions may not apply to you.
4. No warranties are made for units sold outside the continental United States and Canada. Your distributor or final seller may provide a warranty on units sold outside these areas.
5. Comfort-Aire will not be liable for damages if our performance regarding warranty resolution is delayed by events beyond our control including accident, alteration, abuse, war, government restrictions, strikes, fire, flood, or other acts of God.

### HOW TO SUBMIT A WARRANTY CLAIM

If you have a warranty claim, notify your installer or dealer promptly.



Please visit  
[www.heatcontroller.com](http://www.heatcontroller.com)  
to register your new product

### KEEP THIS INFORMATION AS A RECORD OF YOUR PURCHASE

#### PRODUCT IDENTIFICATION

Model Number \_\_\_\_\_

Serial Number \_\_\_\_\_

Date of Purchase \_\_\_\_\_

#### INSTALLATION

Installer Name (if used) \_\_\_\_\_

Phone Number/Contact Information \_\_\_\_\_

Date Installation Completed \_\_\_\_\_

Remember to retain your bill of sale as proof of warranty period.

Comfort-Aire\_5-2023

The design and specifications are subject to change without prior notice for product improvement. Consult with the sales agency or manufacturer for details. Any updates to the manual will be uploaded to the service website, please check for the latest version.

---

Due to ongoing product improvements, specifications and dimensions are subject to change and correction without notice or incurring obligations. Determining the application and suitability for use of any product is the responsibility of the installer. Additionally, the installer is responsible for verifying dimensional data on the actual product prior to beginning any installation preparations.

Incentive and rebate programs have precise requirements as to product performance and certification. All products meet applicable regulations in effect on date of manufacture; however, certifications are not necessarily granted for the life of a product. Therefore, it is the responsibility of the applicant to determine whether a specific model qualifies for these incentive/rebate programs.

*Comfort-Aire*<sup>®</sup>



66139906109

1900 Wellworth Ave., Jackson MI 49203 • Ph. 517-787-2100 • [www.heatcontroller.com](http://www.heatcontroller.com)