Comfort-Cire®

Century®

**Installation, Operation
& Maintenance
HRC Console Series**

Console HRC Series



Commercial Console Water-Source Heat Pumps 50Hz & 60Hz

Installation, Operation & Maintenance

Table of Contents

Model Nomenclature: Console	
(HRC) Series (60Hz)	3
General Information	4
Unit Physical Data	6
Installation	8
Piping Connections - HRC Size 06-15	10
Piping Connections - HRC Size 18	11
Piping Connections	12
Water-Loop Heat Pump Applications	13
Ground-Loop Heat Pump Applications	14
Ground-Water Heat Pump Applications	15
Water Quality Standards	17
Electrical - Line Voltage	18
Electrical - Low Voltage	21
HRC Series Wiring Diagram Matrix	23
CXM Controls	24
DXM Controls	25
Safety Features - CXM/DXM Controls	27
Unit Commissioning and Operating Conditions	29
Piping System Cleaning and Flushing	30
Unit and System Checkout Procedure	31
Unit Start-Up Procedure	32
Unit Operating Conditions	33
Start-Up Log Sheet	35
Preventive Maintenance	36
Functional Troubleshooting	37
Performance Troubleshooting	38
Troubleshooting Form	39
Warranty (U.S. & Canada)	40
Revision History	43

Model Nomenclature: Console (HRC) Series (60Hz)

SERIES
HRC = Heat Controller Console (R410A)

UNIT SIZE
09
12
15
18

REVISION LEVEL
A = Current Revision All Sizes

VOLTAGE
0 = 115/60/1 (SIZE 09 & 12 ONLY)
1 = 208-230/60/1
8 = 255/60/1

CONTROLS

C = ACO UNIT MOUNTED TSTAT w/ CXM
D = ACO UNIT MOUNTED TSTAT w/ DXM
R = REMOTE MOUNTED TSTAT w/ CXM
S = REMOTE MOUNTED TSTAT w/ DXM
L = REMOTE MOUNTED LON w/ CXM
M = REMOTE MOUNTED LON w/ DXM
N = REMOTE MOUNTED MPC w/ CXM
P = REMOTE MOUNTED MPC w/ DXM

PIPING CONNECTIONS
R = RIGHT PIPING
L = LEFT PIPING
V = LEFT PIPING w/S.S. DRAIN PAN
W = RIGHT PIPING w/S.S. DRAIN PAN

WATER CIRCUIT OPTIONS	Sweat	FPT	MPT
None	S	F	M
Motorized Water Valve	A	G	N
AutoFlow (2.25 gpm/ton)	B	H	P
AutoFlow (3.0 gpm/ton)	C	J	Q
Motorized Water Valve & AFR (2.25)	D	K	R
Motorized Water Valve & AFR (3.0)	E	L	T
Secondary Circulation Pump	U	V	W

Flow Regulator Reference

Size	Option B.H.P.D.K.R		Option C.J.Q.E.L.T	
	US GPM	LPS	US GPM	LPS
HRC09	2.0	0.126	2.5	0.158
HRC12	2.5	0.158	3.0	0.189
HRC15	3.0	0.189	3.5	0.221
HRC18	3.5	0.221	4.0	0.252

GPM = Gallons Per Minute
LPS = Liters Per Second

HEAT EXCHANGER OPTIONS

A = Copper Water Coil w/E-Coated Air Coil
C = Copper Water Coil w/Non-Coated Air Coil
J = Cupro-Nickel Water Coil w/E-Coated Air Coil
N = Cupro-Nickel Water Coil w/Non-Coated Air Coil
V = Copper Water Coil w/E-Coated Air Coil
E = Copper Water Coil w/Non-Coated Air Coil
M = Cupro-Nickel Water Coil w/E-Coated Air Coil
F = Cupro-Nickel Water Coil w/Non-Coated Air Coil

SUBBASE
S = 5" SUBBASE (BLACK)
H = 5" SUBBASE w/MOTORIZED DAMPER
N = NONE

CABINET AND CONSTRUCTION

M = BOTTOM RETURN w/ULTRAQUIET
D = BOTTOM RETURN w/LOCKING CONTROL DOOR w/MUTE
B = FRONT RETURN w/ULTRAQUIET
E = FRONT RETURN w/LOCKING CONTROL DOOR w/ULTRAQUIET
C = NO CABINET, BOTTOM RETURN CHASSIS ONLY w/ULTRAQUIET
J = NO CABINET, FRONT RETURN CHASSIS ONLY w/ULTRAQUIET
S = BOTTOM RETURN (STANDARD)
L = BOTTOM RETURN w/LOCKING CONTROL DOOR (STANDARD)
F = FRONT RETURN (STANDARD)
G = FRONT RETURN w/LOCKING CONTROL DOOR (STANDARD)
N = NO CABINET, BOTTOM RETURN CHASSIS ONLY
H = NO CABINET, FRONT RETURN CHASSIS ONLY (STANDARD)

POWER TERMINATION & OPTIONS

OPTION	FIELD CONNECTED (HARD WIRE)	20-Amp PLUG & COFD	DISCONNECT SWITCH	BREAKER	RECEPTACLE
A	X	-	-	-	-
B	-	X	-	-	-
D	-	-	-	X	-
F	-	-	X	-	-
K	-	X	X	-	X

NOTES:

- UNITS ARE ETL APPROVED FOR USA & CANADA.
- UNITS WITH CXM CONTROLLERS COME STANDARD WITH 50VA TRANSFORMERS. UNITS WITH DXM, LON OR MPC CONTROLLERS COME STANDARD WITH 75VA TRANSFORMERS.
- "CHASSIS ONLY" IS FOR FRONT & BOTTOM RETURN, REPLACEMENT UNIT.
- FOR SECONDARY PUMP OPTION DIGIT 7 MUST BE "1"(208-230). DIGIT 9 MUST BE "A", "D", or "F" (HARDWARE).
- HRC 09-15 WATER CONNECTIONS 1/2".
HRC 18 WATER CONNECTIONS 3/4".
- HRC09-15 w/SECONDARY PUMP SHALL BE IN EXTENDED CABINET 54" LONG.
HRC18 w/SECONDARY PUMP SHALL BE IN EXTENDED CABINET 60" LONG.
- AVAILABLE IN 115VOLT & 208-230 VOLT ONLY.



General Information

Safety

Warnings, cautions, and notices appear throughout this manual. Read these items carefully before attempting any installation, service, or troubleshooting of the equipment.

DANGER: Indicates an immediate hazardous situation, which if not avoided will result in death or serious injury. DANGER labels on unit access panels must be observed.

WARNING: Indicates a potentially hazardous situation, which if not avoided could result in death or serious injury.

⚠ WARNING! ⚠

WARNING! The EarthPure® Application and Service Manual should be read and understood before attempting to service refrigerant circuits with HFC-410A.

⚠ WARNING! ⚠

WARNING! To avoid the release of refrigerant into the atmosphere, the refrigerant circuit of this unit must be serviced only by technicians who meet local, state, and federal proficiency requirements.

⚠ WARNING! ⚠

WARNING! The installation of water-source heat pumps and all associated components, parts, and accessories which make up the installation shall be in accordance with the regulations of ALL authorities having jurisdiction and MUST conform to all applicable codes. It is the responsibility of the installing contractor to determine and comply with ALL applicable codes and regulations.

⚠ WARNING! ⚠

WARNING! This appliance is not intended for use by persons (including children) with reduced physical, sensory, or mental capabilities, or lack of experience and knowledge, unless they have been given supervision or instruction concerning use of the appliance by a person responsible for their safety.

CAUTION: Indicates a potentially hazardous situation or an unsafe practice, which if not avoided could result in minor or moderate injury or product or property damage.

NOTICE: Notification of installation, operation, or maintenance information, which is important, but which is not hazard-related.

⚠ WARNING! ⚠

WARNING! All refrigerant discharged from this unit must be recovered WITHOUT EXCEPTION. Technicians must follow industry accepted guidelines and all local, state, and federal statutes for the recovery and disposal of refrigerants. If a compressor is removed from this unit, refrigerant circuit oil will remain in the compressor. To avoid leakage of compressor oil, refrigerant lines of the compressor must be sealed after it is removed.

⚠ CAUTION! ⚠

CAUTION! To avoid equipment damage, DO NOT use these units as a source of heating or cooling during the construction process. The mechanical components and filters can quickly become clogged with construction dirt and debris, which may cause system damage and void product warranty.

Inspection - Upon receipt of the equipment, carefully check the shipment against the bill of lading. Make sure all units have been received. Inspect the packaging of each unit, and inspect each unit for damage. Insure that the carrier makes proper notation of any shortages or damage on all copies of the freight bill and completes a common carrier inspection report. Concealed damage not discovered during unloading must be reported to the carrier within 15 days of receipt of shipment. If not filed within 15 days, the freight company can deny the claim without recourse. Note: It is the responsibility of the purchaser to file all necessary claims with the carrier. Notify your equipment supplier of all damage within fifteen (15) days of shipment.

Storage - Equipment should be stored in its original packaging in a clean, dry area. Store units in an upright position at all times. Stack units a maximum of 3 units high.

Unit Protection - Cover units on the job site with either the original packaging or an equivalent protective covering. Cap the open ends of pipes stored on the job site. In areas where painting, plastering, and/or spraying has not been completed, all due precautions must be taken to avoid physical damage to the units and contamination by foreign material. Physical damage and contamination may prevent proper start-up and may result in costly equipment clean-up.

Examine all pipes, fittings, and valves before installing any of the system components. Remove any dirt or debris found in or on these components.

Pre-Installation - Installation, Operation, and Maintenance instructions are provided with each unit. Horizontal equipment is designed for installation above false ceiling or in a ceiling plenum. Other unit configurations are typically installed in a mechanical room. The installation site chosen should include adequate service clearance around the unit. Before unit start-up, read all manuals and become familiar with the unit and its operation. Thoroughly check the system before operation. Make sure wall behind the unit is flat and smooth.

Prepare units for installation as follows:

1. Compare the electrical data on the unit nameplate with ordering and shipping information to verify that the correct unit has been shipped.
2. Keep the cabinet covered with the original packaging until installation is complete and all plastering, painting, etc. is finished.
3. Verify refrigerant tubing is free of kinks or dents and that it does not touch other unit components.
4. Inspect all electrical connections. Connections must be clean and tight at the terminals.

⚠ CAUTION! ⚠

CAUTION! DO NOT store or install units in corrosive environments or in locations subject to temperature or humidity extremes (e.g., attics, garages, rooftops, etc.). Corrosive conditions and high temperature or humidity can significantly reduce performance, reliability, and service life. Always move and store units in an upright position. Tilting units on their sides may cause equipment damage.

⚠ CAUTION! ⚠

CAUTION! CUT HAZARD - Failure to follow this caution may result in personal injury. Sheet metal parts may have sharp edges or burrs. Use care and wear appropriate protective clothing, safety glasses and gloves when handling parts and servicing heat pumps.

Unit Physical Data

Console (HRC) Series (60Hz)

Model	09	12	15	18
Compressor (1 Each)	Rotary			
Factory Charge HFC-410A (oz) [kg]	28 [0.794]	29 [0.822]	33 [0.907]	39 [1.105]
Blower Wheel				
Blower Wheel Size (dia x w) - (in) [mm] - Qty 2	5.25 x 6.25 [133 x 159]			
Water Connection Size				
O.D. Sweat (in) [mm]	1/2 [12.7]		3/4 [19.1]	
Optional FPT Fittings (in)	1/2		3/4	
Optional MPT Fittings (in)	1/2		3/4	
Coax Volume				
Volume US Gal [Liters]	.09 [.34]	.09 [.34]	.23 [.87]	.26 [.98]
Condensate Connection Size				
I.D. Vinyl Hose (In) [mm]	5/8 [15.9]			
Air Coil Size				
Dimensions (h x w) - (in) [mm]	8 x 26 [203 x 660]	10 x 26 [254 x 660]	10 x 32 [254 x 812]	
Filter Size				
Bottom Return (in) [mm]	1 - 10 x 30 x 1 [254 x 762 x 25]		1 - 10 x 36 x 1 [254 x 914 x 25]	
Front Return (In) [mm]	1 - 7 x 29.5 x 1/8 [178 x 749 x 3.2]		1 - 7 x 35.5 x 1/8 [178 x 902 x 3.2]	
Unit Size				
Bottom Return (Std. 5" Base) (W x H x D) - (In) [mm]	48 x 26 x 12 [1219 x 660 x 305]		54 x 26 x 12 [1372 x 660 x 305]	
Front Return (No Subbase) (W x H x D) - (In) [mm]	48 x 21 x 12 [1219 x 533 x 305]		54 x 21 x 12 [1372 x 533 x 305]	
Unit Weight				
Weight - Operating, (lbs) [kg]	175 [79]	180 [82]	190 [86.2]	220 [99.8]
Weight - Packaged, (lbs) [kg]	185 [83.9]	190 [86]	200 [90.8]	232 [105.2]

All units have rubber grommet compressor mountings and TXV expansion devices.

Unit Maximum Water Working Pressure	
Options	Max Pressure PSIG [kPa]
Base Unit	500 [3,445]
Internal Secondary Pump (ISP)	145 [999]
Internal Motorized Water Valve (MWV)	300 [2,068]
Internal Auto Flow Valve	500 [3,445]

Use the lowest maximum pressure rating when multiple options are combined. Optional hoses have pressure rating of 400 PSIG (2758 kPa)

Optional Factory Installed Auto Flow Regulator GPM [LPS]		
Model	2.25 GPM/Ton	3 GPM/Ton
9	2.0 [.126]	2.5 [.158]
12	2.5 [.158]	3.0 [.189]
15	3.0 [.189]	3.5 [.221]
18	3.5 [.221]	4.0 [.252]

Console (HRC) Series (50Hz)

Model	09	12	15	18
Compressor (1 Each)	Rotary			
Factory Charge R410A (oz) [kg]	28 [0.794]	29 [0.822]	33 [0.936]	39 [1.105]
PSC Fan Motor & Blower (3 Speeds)				
Fan Motor (hp) [W]	1/20 [37]	1/12 [62]	1/8 [93]	1/8 [93]
Blower Wheel Size (dia x w) - (in) [mm] - Qty 2	5.25 x 6.25 [133 x 159]			
Water Connection Size				
O.D. Sweat (in) [mm]	1/2 [12.7]		3/4 [19.1]	
Optional IPT Fittings (in)	1/2		3/4	
Optional EPT Fittings (in)	1/2		3/4	
Condensate Connection Size				
I.D. Vinyl Hose (In) [mm]	5/8 [15.9]			
Air Coil Size				
Dimensions (h x w) - (in) [mm]	8 x 26 [203 x 660]	10 x 26 [254 x 660]		10 x 32 [254 x 813]
Filter Size				
Bottom Return (in) [mm]	1 - 10 x 30 x 1 [254 x 762 x 25]			1 - 10 x 36 x 1 [25.4 x 91.4 x 2.5]
Front Return (In) [mm]	1 - 7 x 29.5 x 1/8 [178 x 749 x 3.2]			1 - 7 x 35.5 x 1/8 [178 x 902 x 3.2]
Cabinet Size				
Bottom Return (Std. 5" [127] Base) (W x H x D) - (In) [mm]	48 x 26 x 12 [1219 x 660 x 305]			54 x 26 x 12 [1372 x 660 x 305]
Front Return (No Subbase) (W x H x D) - (In) [mm]	48 x 21 x 12 [1219 x 533 x 305]			54 x 21 x 12 [1372 x 533 x 305]
Cabinet Size				
Weight - Operating, (lbs) [kg]	175 [79]	180 [82]	190 [86.2]	220 [99.8]
Weight - Packaged, (lbs) [kg]	185 [83.9]	190 [86]	200 [90.8]	232 [105.2]

All units have rubber grommet compressor mountings and TXV expansion devices.

Unit Maximum Water Working Pressure	
Options	Max Pressure PSIG [kPa]
Base Unit	500 [3,445]
Internal Secondary Pump (ISP)	145 [999]
Internal Motorized Water Valve (MWV)	300 [2,068]
Internal Auto Flow Valve	500 [3,445]

Use the lowest maximum pressure rating when multiple options are combined. Optional hoses have pressure rating of 400 PSIG (2758 kPa)

Optional Factory Installed Auto Flow Regulator GPM [LPS]		
Model	2.25 GPM/Ton	3 GPM/Ton
9	2.0 [.126]	2.5 [.158]
12	2.5 [.158]	3.0 [.189]
15	3.0 [.189]	3.5 [.221]
18	3.5 [.221]	4.0 [.252]

Installation

The installation of Console Water-Source Heat Pumps and all associated components, parts and accessories that make up the installation shall be in accordance with the regulations of ALL Authorities having jurisdiction and MUST conform to all applicable Codes. It is the responsibility of the Installing Contractor to determine and comply with ALL applicable Codes and Regulations.

Note: An Installation Checklist is provided in this manual. Complete this checklist after all installation procedures are completed. A periodic maintenance checklist provided in the Maintenance section outlines recommended maintenance schedules. A Start-Up Inspection Log is also included at the end of this manual to encourage thorough unit checkout at initial start-up. These checklists are not a substitute for the detailed information found in the Installation section of this manual.

1. Console units are typically installed along an outside wall of the room. Provide adequate space in front of the unit for service and maintenance. Locate the Console Unit so that it provides adequate air circulation throughout the room.
2. Unpack the Console Unit from the shipping carton. Remove the front cabinet by lifting up and away from the backplate. Protect the cabinet from damage during installation by returning it to its original packaging until required.
3. Using a carpenter's square and a level, ensure the unit is level. Shim the unit if necessary to assure proper installation.
4. Select the proper fasteners to connect the backplate securely to the wall.
5. Fasten the backplate onto the wall through the screw holes located in the back flange. Secure the subbase in place.
6. Remove subbase shipping support bracket and discard.
7. Make all necessary electrical connections as described in the Electrical Wiring section of this manual. Consult the wiring diagram to ensure proper hook-up.
8. Connect the final piping as described in the Supply and Return Piping and Condensate Piping section of the manual. Install shut-off valves, piping and/or hoses and other accessories as specified.
9. Before making the final water connections, flush the system as described in the Start Up section of this manual. After flushing the system, connect piping and hoses to the proper supply, return and condensate connections of the unit.

Note: When necessary, use adapters to connect hoses.

10. Install any other system components as required following manufacturer's instructions.
11. After Start-up, reinstall the front cabinet by carefully lowering the front cabinet over the chassis onto the backplate.

Supply and Return Hoses - Optional pressure-rated hose assemblies 400 psi [2758 kPa] are available for use with Comfort-Aire/Century Console Units. Use the following guidelines when installing supply and return hose assemblies.

1. Install supply and return hoses fitted with swivel-joint fittings at one end to prevent the hose from twisting.
2. Use adapters to secure the hose assembly to the unit and the riser.
3. Do not allow the hose to twist during installation. Twisting may damage the hose wall or the interior rubber compound.
4. Use pipe joint compound sparingly on the pipe threads of the fitting adapters.
5. Prevent sealant from reaching the flared surfaces of the joint.
6. Do not use pipe joint compound when teflon thread tape is pre-applied to hose assemblies or when flared-end connections are used.
7. Maximum torque which may be applied to brass fittings is 30 ft-lbs [41 N-m]. When a torque wrench is not used, tighten brass fittings finger-tight plus one quarter turn.
8. Tighten steel fittings as necessary.
9. Shut-off/balancing valves, flow indicators, and drain tees in the supply runout and return at each floor to aid in loop balancing and servicing.

⚠ CAUTION! ⚠

CAUTION! Poor or inadequate installation may result in noisy unit operation or unattractive installation.

⚠ CAUTION! ⚠

CAUTION! Loop Fluids should be of good quality with no more than 0.50 ppm of chlorides w/copper heat exchangers (125 ppm w/ Cupro-nickel) to prevent corrosion and should also be filtered to a maximum 800 micron [0.8mm particle size to prevent erosion of the heat exchangers.

Condensate Piping - Unit is supplied with condensate drain hose, 5/8 inch [16mm] I.D. flexible plastic nonpressure-rated, protruding from piping side of unit. Connect this hose to building drain. Avoid making kinks in hose to ensure an unobstructed flow of condensate from the unit to the drain. DO NOT twist, pull hose out, or push excess hose into unit. If hose will not connect to your building drain several options include, relocate end of building drain, add to or cut hose, use hard plastic or copper elbow fittings for tight radii (put inside hose). Keep hose positioned within or over subbase area so hose does not interfere with front cabinet. Cabinet should not push or reroute hose. Clamp all joints watertight. Check for leaks.

Internally the drain hose is clamped to drain pan and pitched correctly. Horizontal runs of condensate hose should be pitched downward 1/4 inch minimum for every foot [10mm per 46cm] of hose. Avoid low points because dirt collects in these areas and may cause blockage. If blocked the condensate level in drain pan increases. When the level gets too high, the Console unit has sensor switch that will shut unit off. Overflow may still occur.

If the building drain connection is parallel with floor, the height can be up to 1-1/2 inches [38mm] above the subbase for proper pitch and correct drainage. Up to 5 inches [127mm] above the subbase is allowable, but drainage will be slower. When the drain connection is 2-1/2 to 5 inches [64 to 127mm] above, the hose inside the unit will act as a trap. Heights of more than 5 inches [127mm] above the subbase are NOT allowable (condensate overflow may occur). If the unit has a disconnect option, drain locations are limited. See unit configuration pages for details. Field installation of a trap or vent is not required unless specified by local codes. Console units are designed in a blow-through configuration. The condensate drain pan is located on the outlet side of the blower so that the pressure in the drain pan is higher than atmospheric pressures.

When drain connection is completed check for proper drainage and leaks. Correct if necessary.

If trap is used, check and clean often. See Preventive Maintenance Instructions.

Piping Connections - HRC Size 09-15

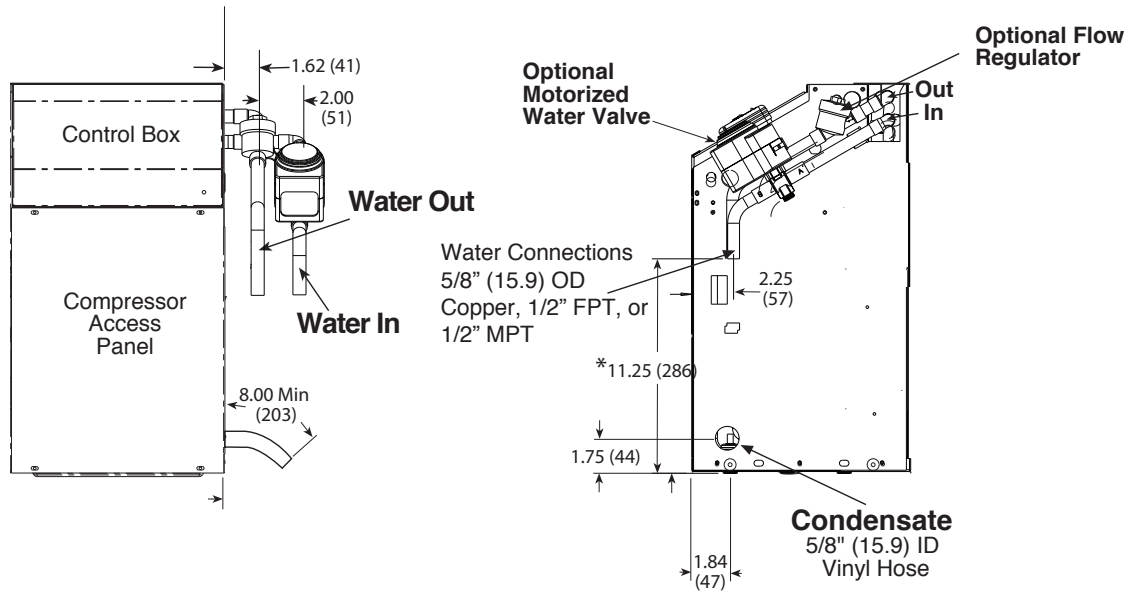

Right Hand Configuration

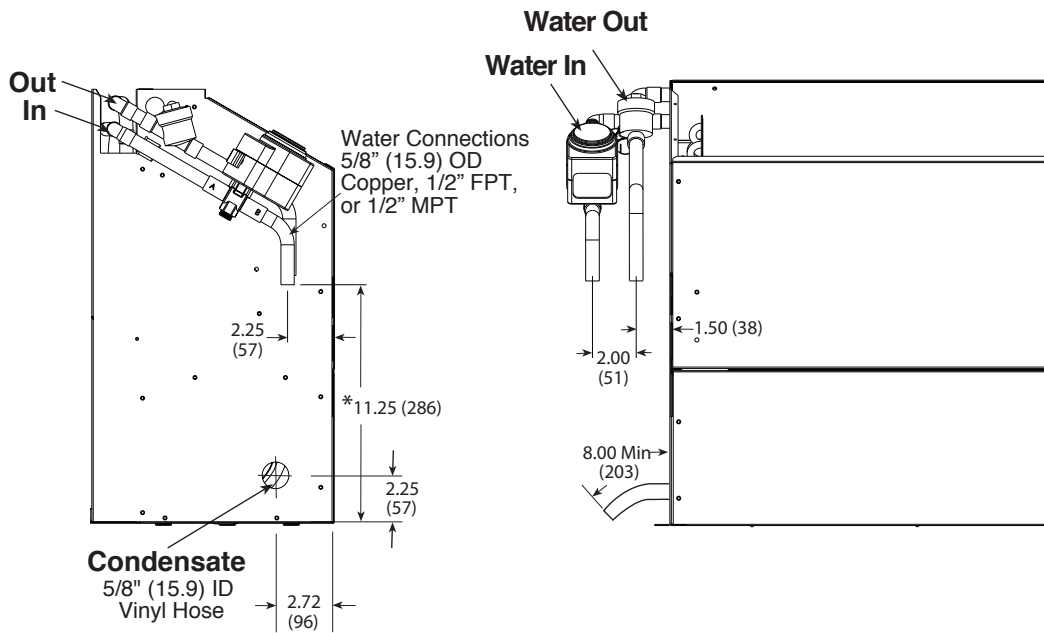

Left Hand Configuration

Notes: * Dimension reduced by fitting if selected

⚠ CAUTION! ⚠
CAUTION! Corrosive system water requires corrosion resistant fittings and hoses, and may require water treatment.

⚠ CAUTION! ⚠
CAUTION! Piping must comply with all applicable codes.

Piping Connections - HRC Size 18

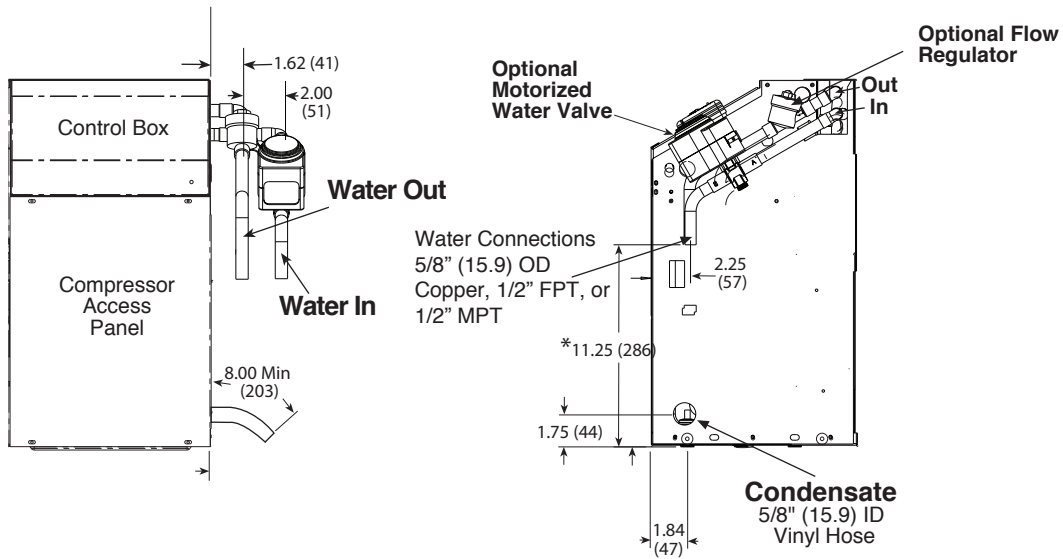

Right Hand Configuration

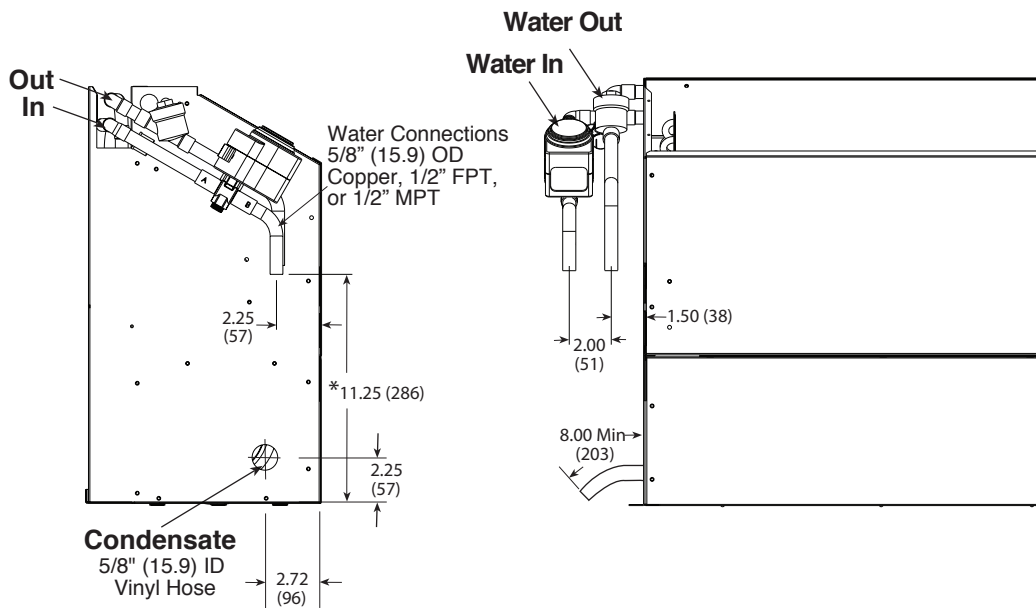

Left Hand Configuration

Notes: * Dimension reduced by fitting if selected

⚠ CAUTION! ⚠

CAUTION! Corrosive system water requires corrosion resistant fittings and hoses, and may require water treatment.

⚠ CAUTION! ⚠

CAUTION! Piping must comply with all applicable codes.

Piping Connections

Installation of Supply and Return Piping - Follow these piping guidelines.

1. Install a drain valve at the base of each supply and return riser to facilitate system flushing.
2. Install shut-off / balancing valves and unions at each unit to permit unit removal for servicing.
3. Place strainers at the inlet of each system circulating pump.
4. Select the proper hose length to allow slack between connection points. Hoses may vary in length by +2% to -4% under pressure.
5. Refer to Table 1. Do not exceed the minimum bend radius for the hose selected. Exceeding the minimum bend radius may cause the hose to collapse, which reduces water flow rate. Install an angle adapter to avoid sharp bends in the hose when the radius falls below the required minimum.

Insulation is not required on loop water piping except where the piping runs through unheated areas, outside the building or when the loop water temperature is below the minimum expected dew point of the pipe ambient conditions. Insulation is required if loop water temperature drops below the dew point (insulation is required for ground loop applications in most climates).

Pipe joint compound is not necessary when Teflon® thread tape is pre-applied to hose assemblies or when flared-end connections are used. If pipe joint compound is preferred, use compound only in small amounts on the external pipe threads of the fitting adapters. Prevent sealant from reaching the flared surfaces of the joint.

Note: When antifreeze is used in the loop, insure that it is compatible with the Teflon tape or pipe joint compound that is applied.

Maximum allowable torque for brass fittings is 30 ft-lbs [41 N-m]. If a torque wrench is not available, tighten finger-tight plus one quarter turn. Tighten steel fittings as necessary.

Optional pressure-rated hose assemblies designed specifically for use with Comfort-Aire/Century units are available. Similar hoses can be obtained from alternate suppliers. Supply and return hoses are fitted with swivel-joint fittings at one end to prevent kinking during installation.

Refer to Figure 2 for an illustration of a typical supply/return hose kit. Adapters secure hose assemblies to the unit and risers. Install hose assemblies properly and check regularly to avoid system failure and reduced service life.

⚠ WARNING! ⚠

WARNING! Polyolester Oil, commonly known as POE oil, is a synthetic oil used in many refrigeration systems including those with HFC-410A refrigerant. POE oil, if it ever comes in contact with PVC or CPVC piping, may cause failure of the PVC/CPVC. PVC/CPVC piping should never be used as supply or return water piping with water source heat pump products containing HFC-410A as system failures and property damage may result.

⚠ CAUTION! ⚠

CAUTION! Do not bend or kink supply lines or hoses.

Table 1: Metal Hose Minimum Bend Radii

Hose Diameter	Minimum Bend Radii
1/2" [12.7mm]	2-1/2" [6.4cm]
3/4" [19.1mm]	4" [10.2cm]
1" [25.4mm]	5-1/2" [14cm]

NOTICE! Do not allow hoses to rest against structural building components. Compressor vibration may be transmitted through the hoses to the structure, causing unnecessary noise complaints.

Figure 2: Supply/Return Hose Kit

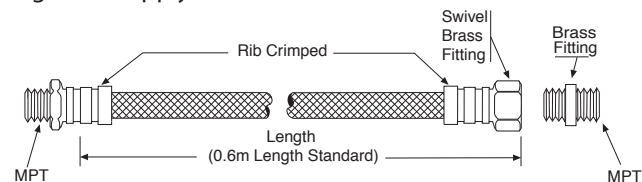

Water-Loop Heat Pump Applications

Commercial Water Loop Applications - Commercial systems typically include a number of units connected to a common piping system. Any unit plumbing maintenance work can introduce air into the piping system; therefore air elimination equipment is a major portion of the mechanical room plumbing. In piping systems expected to utilize water temperatures below 50°F [10°C], 1/2" (13mm) closed cell insulation is required on all piping surfaces to eliminate condensation (extended range units required). Metal to plastic threaded joints should never be used due to their tendency to leak over time.

Teflon tape thread sealant is recommended to minimize internal fouling of the heat exchanger. Do not over tighten connections and route piping so as not to interfere with service or maintenance access. Hose kits are available from Comfort-Aire/Century in different configurations for connection between the unit and the piping system. Depending upon selection, hose kits may include shut off valves, P/T plugs for performance measurement, high pressure stainless steel braided hose, "Y" type strainer with blow down valve, and/or "J" type swivel connection. Balancing valves and an external low pressure drop solenoid valve for use in variable speed pumping systems may also be included in the hose kit.

The piping system should be flushed to remove dirt, piping chips, and other foreign material prior to operation (see "Piping System Cleaning and Flushing Procedures" in this manual). The flow rate is usually set between 2.25 and 3.5 gpm per ton [2.9 and 4.5 l/m per kW] of cooling capacity. Comfort-Aire/Century recommends 3 gpm per ton [3.9 l/m per kW] for most applications of water loop heat pumps. To insure proper maintenance and servicing, P/T ports are imperative for temperature and flow verification, as well as performance checks.

Water loop heat pump (cooling tower/boiler) systems typically utilize a common loop, maintained between 60 - 90°F [16 - 32°C]. The use of a closed circuit evaporative cooling tower with a secondary heat exchanger between the tower and the water loop is recommended. If an open type cooling tower is used continuously, chemical treatment and filtering will be necessary.

Low Water Temperature Cutout Setting - CXM Control
When antifreeze is selected, the LT1 jumper (JW3) should be clipped to select the low temperature (antifreeze 10.0°F [-12.2°C]) setpoint and avoid nuisance faults (see "Low Water Temperature Cutout Selection" in this manual). Note: Low water temperature operation requires extended range equipment.

Table 2: Antifreeze Percentages by Volume

Type	Minimum Temperature for Freeze Protection			
	10°F [-12.2°C]	15°F [-9.4°C]	20°F [6.7°C]	25°F [-3.9°C]
Methanol - 100% USP food grade	25%	21%	16%	10%
Propylene Glycol	38%	30%	22%	15%

Ground-Loop Heat Pump Applications

⚠ CAUTION! ⚠

CAUTION! The following instructions represent industry accepted installation practices for closed loop earth coupled heat pump systems. Instructions are provided to assist the contractor in installing trouble free ground loops. These instructions are recommendations only. State/provincial and local codes **MUST** be followed and installation **MUST** conform to **ALL** applicable codes. It is the responsibility of the installing contractor to determine and comply with **ALL** applicable codes and regulations.

⚠ CAUTION! ⚠

CAUTION! Ground loop applications require extended range equipment and optional refrigerant/water circuit insulation.

Pre-Installation - Prior to installation, locate and mark all existing underground utilities, piping, etc. Install loops for new construction before sidewalks, patios, driveways, and other construction has begun. During construction, accurately mark all ground loop piping on the plot plan as an aid in avoiding potential future damage to the installation.

Piping Installation - All earth loop piping materials should be limited to polyethylene fusion only for in-ground sections of the loop. Galvanized or steel fittings should not be used at any time due to their tendency to corrode. All plastic to metal threaded fittings should be avoided due to their potential to leak in earth coupled applications. A flanged fitting should be substituted. P/T plugs should be used so that flow can be measured using the pressure drop of the unit heat exchanger.

Earth loop temperatures can range between 25 and 110°F [-4 to 43°C]. Flow rates between 2.25 and 3 gpm per ton [2.41 to 3.23 l/m per kW] of cooling capacity is recommended in these applications.

Test individual horizontal loop circuits before backfilling. Test vertical U-bends and pond loop assemblies prior to installation. Pressures of at least 100 psi [689 kPa] should be used when testing. Do not exceed the pipe pressure rating. Test entire system when all loops are assembled.

Flushing the Earth Loop - Upon completion of system installation and testing, flush the system to remove all foreign objects and purge to remove all air.

Antifreeze - If any liquid fluid or piping is exposed to unconditioned ambient below 42°F (5.5 C), antifreeze must be added. If the liquid fluid entering the heat pump is 50°F (10°C) or below, calculate the leaving heat pump temperature (shown in submittal on performance data selection notes section). Using the lowest temperature leaving the heat pump, must protect system 15°F (8°C) lower. IE: if temperature leaving the heat pump is 35°F subtract 15°F = 20°F protection required, if Methanol is used the system would require 16% mix by volume. Antifreeze is available in alcohol and glycols, contact local sales office for the best type for your system and area. Following must be considered safety, thermal performance, corrosiveness, local codes, stability, convenience, and cost.

All alcohols should be premixed and pumped from a reservoir outside of the building when possible or introduced under the water level to prevent fumes. Calculate the total volume of fluid in the piping system. Then use the percentage by volume shown in table 2 for the amount of antifreeze needed. Antifreeze concentration should be checked from a well mixed sample using a hydrometer to measure specific gravity.

Low Water Temperature Cutout Setting - CXM Control
When antifreeze is selected, the LT1 jumper (JW3) should be clipped to select the low temperature (antifreeze 10.0°F [-12.2°C]) setpoint and avoid nuisance faults (see "Low Water Temperature Cutout Selection" in this manual). Note: Low water temperature operation requires extended range equipment.

Ground-Water Heat Pump Applications

Open Loop - Ground Water Systems - Shut off valves should be included for ease of servicing. Boiler drains or other valves should be "tee'd" into the lines to allow acid flushing of the heat exchanger. Shut off valves should be positioned to allow flow through the coax via the boiler drains without allowing flow into the piping system. P/T plugs should be used so that pressure drop and temperature can be measured. Supply and return water piping materials should be limited to copper, PE, or similar material. PVC or CPVC should never be used as they are incompatible with the POE oils used in HFC-410A products and piping system failure and property damage may result.

⚠ WARNING! ⚠

WARNING! Polyolester Oil, commonly known as POE oil, is a synthetic oil used in many refrigeration systems including those with HFC-410A refrigerant. POE oil, if it ever comes in contact with PVC or CPVC piping, may cause failure of the PVC/CPVC. PVC/CPVC piping should never be used as supply or return water piping with water source heat pump products containing HFC-410A as system failures and property damage may result.

Water quantity should be plentiful and of good quality. Consult table 3 for water quality guidelines. The unit can be ordered with either a copper or cupro-nickel water heat exchanger. Consult Table 3 for recommendations. Copper is recommended for closed loop systems and open loop ground water systems that are not high in mineral content or corrosiveness. In conditions anticipating heavy scale formation or in brackish water, a cupro-nickel heat exchanger is recommended. In ground water situations where scaling could be heavy or where biological growth such as iron bacteria will be present, an open loop system is not recommended. Heat exchanger coils may over time lose heat exchange capabilities due to build up of mineral deposits. Heat exchangers must only be serviced by a qualified technician, as acid and special pumping equipment is required. Desuperheater coils can likewise become scaled and possibly plugged. In areas with extremely hard water, the owner should be informed that the heat exchanger may require occasional acid flushing. In some cases, the desuperheater option should not be recommended due to hard water conditions and additional maintenance required.

Water Quality Standards - Table 3 should be consulted for water quality requirements. Scaling potential should be assessed using the pH/Calcium hardness method. If the pH <7.5 and the calcium hardness is less than 100 ppm, scaling potential is low. If this method yields numbers out of range of those listed, the Ryznar Stability

and Langelier Saturation indices should be calculated. Use the appropriate scaling surface temperature for the application, 150°F [66°C] for direct use (well water/open loop) and DHW (desuperheater); 90°F [32°F] for indirect use. A monitoring plan should be implemented in these probable scaling situations. Other water quality issues such as iron fouling, corrosion prevention and erosion and clogging should be referenced in Table 3.

Expansion Tank and Pump - Use a closed, bladder-type expansion tank to minimize mineral formation due to air exposure. The expansion tank should be sized to provide at least one minute continuous run time of the pump using its drawdown capacity rating to prevent pump short cycling. Discharge water from the unit is not contaminated in any manner and can be disposed of in various ways, depending on local building codes (e.g. recharge well, storm sewer, drain field, adjacent stream or pond, etc.). Most local codes forbid the use of sanitary sewer for disposal. Consult your local building and zoning department to assure compliance in your area.

Water Control Valve - Always maintain water pressure in the heat exchanger by placing the water control valve(s) on the discharge line to prevent mineral precipitation during the off-cycle. Pilot operated slow closing valves are recommended to reduce water hammer. If water hammer persists, a mini-expansion tank can be mounted on the piping to help absorb the excess hammer shock. Insure that the total 'VA' draw of the valve can be supplied by the unit transformer. For instance, a slow closing valve can draw up to 35VA. This can overload smaller 40 or 50 VA transformers depending on the other controls in the circuit. A typical pilot operated solenoid valve draws approximately 15VA..

Flow Regulation - Flow regulation can be accomplished by two methods. One method of flow regulation involves simply adjusting the ball valve or water control valve on the discharge line. Measure the pressure drop through the unit heat exchanger, and determine flow rate. Since the pressure is constantly varying, two pressure gauges may be needed. Adjust the valve until the desired flow of 1.5 to 2 gpm per ton [2.0 to 2.6 l/m per kW] is achieved. A second method of flow control requires a flow control device mounted on the outlet of the water control valve. The device is typically a brass fitting with an orifice of rubber or plastic material that is designed to allow a specified flow rate. On occasion, flow control devices may produce velocity noise that can be reduced by applying some back pressure from the ball valve located on the discharge line. Slightly closing the valve will spread the pressure drop over both devices, lessening the velocity noise. Note: When EWT is below 50°F [10°C], 2 gpm per ton (2.6 l/m per kW) is required.

Ground-Water Heat Pump Applications

Water Coil Low Temperature Limit Setting - For all open loop systems the 30°F [-1.1°C] LT1 setting (factory setting-water) should be used to avoid freeze damage to the unit. See "Low Water Temperature Cutout Selection" in this manual for details on the low limit setting.

Notice! Ground-water applications for commercial buildings with more than 2-3 units should include a plate frame heat-exchanger to isolate the heat pumps from the ground-water and confine heat exchanger cleanings to one location and lessen maintenance. Direct use of ground-water may increase the frequency of heat pump maintenance and may shorten life expectancy.

Water Quality Standards

Table 2: Water Quality Standards

Water Quality Parameter	HX Material	Closed Recirculating	Open Loop and Recirculating Well		
Scaling Potential - Primary Measurement					
Above the given limits, scaling is likely to occur. Scaling indexes should be calculated using the limits below					
pH/Calcium Hardness Method	All	-	pH < 7.5 and Ca Hardness <100ppm		
Index Limits for Probable Scaling Situations - (Operation outside these limits is not recommended)					
Scaling indexes should be calculated at 66°C for direct use and HWG applications, and at 32°C for indirect HX use. A monitoring plan should be implemented.					
Ryznar Stability Index	All	-	6.0 - 7.5 If >7.5 minimize steel pipe use.		
Langelier Saturation Index	All	-	-0.5 to +0.5 If <-0.5 minimize steel pipe use. Based upon 66°C HWG and Direct well, 29°C Indirect Well HX		
Iron Fouling					
Iron Fe ²⁺ (Ferrous) (Bacterial Iron potential)	All	-	<0.2 ppm (Ferrous) If Fe ²⁺ (ferrous)>0.2 ppm with pH 6 - 8, O ₂ <5 ppm check for iron bacteria.		
Iron Fouling	All	-	<0.5 ppm of Oxygen Above this level deposition will occur.		
Corrosion Prevention					
pH	All	6 - 8.5 Monitor/treat as needed	6 - 8.5 Minimize steel pipe below 7 and no open tanks with pH <8		
Hydrogen Sulfide (H ₂ S)	All	-	<0.5 ppm At H ₂ S>0.2 ppm, avoid use of copper and copper nickel piping or HX's. Rotten egg smell appears at 0.5 ppm level. Copper alloy (bronze or brass) cast components are OK to <0.5 ppm.		
Ammonia ion as hydroxide, chloride, nitrate and sulfate compounds	All	-	<0.5 ppm		
Maximum Chloride Levels	Maximum Allowable at maximum water temperature.				
			10°C	24°C	38°C
	Copper	-	<20ppm	NR	NR
	Cupronickel	-	<150 ppm	NR	NR
	304 SS	-	<400 ppm	<250 ppm	<150 ppm
316 SS	-	<1000 ppm	<550 ppm	< 375 ppm	
Titanium	-	>1000 ppm	>550 ppm	>375 ppm	
Erosion and Clogging					
Particulate Size and Erosion	All	<10 ppm of particles and a maximum velocity of 1.8 m/s Filtered for maximum 841 micron [0.84 mm, 20 mesh] size.	<10 ppm (<1 ppm "sandfree" for reinjection) of particles and a maximum velocity of 1.8 m/s. Filtered for maximum 841 micron 0.84 mm, 20 mesh] size. Any particulate that is not removed can potentially clog components.		

The Water Quality Table provides water quality requirements for coaxial heat exchangers. The water should be evaluated by an independent testing facility comparing to this Table and when properties are outside of these requirements, an external secondary heat exchanger must be used to isolate the heat pump heat exchanger from the unsuitable water. Failure to do so will void the warranty for the coaxial heat exchanger and any other components damaged by a leak.

Notes:

- Closed Recirculating system is identified by a closed pressurized piping system.
- Recirculating open wells should observe the open recirculating design considerations.
- NR - Application not recommended.
- "-" No design Maximum.

Electrical - Line Voltage

⚠ WARNING! ⚠

WARNING! To avoid possible injury or death due to electrical shock, open the power supply disconnect switch and secure it in an open position during installation.

⚠ CAUTION! ⚠

CAUTION! Use only copper conductors for field installed electrical wiring. Unit terminals are not designed to accept other types of conductors.

Electrical - Line Voltage - All field installed wiring, including electrical ground, must comply with the National Electrical Code as well as all applicable local codes. Refer to the unit electrical data for fuse sizes. Consult wiring diagram for field connections that must be made by the installing (or electrical) contractor. All final electrical connections must be made with a length of flexible conduit to minimize vibration and sound transmission to the building.

General Line Voltage Wiring - Be sure the available power is the same voltage and phase shown on the unit serial plate. Line and low voltage wiring must be done in accordance with local codes or the National Electric Code, whichever is applicable.

Power Connection - Line voltage connection is made by connecting the incoming line voltage wires to the "L" side of the contactor. Consult Tables 4 through 5 for correct fuse size.

Transformer - All commercial dual voltage units are factory wired for 208/60/1 or 240/50/1. If supply voltage is 230/60/1 or 220/50/1, installer must rewire transformer. See wire diagram for connections.

Table 4: HRC Electrical Data (60Hz)

Model	Voltage Code	Voltage	Min/Max Voltage	Compressor		Fan Motor FLA	Pump Option FLA	Total Unit FLA	Min Circuit Amps	Max Fuse Amps
				RLA	LRA					
HRC09	0	115/60/1	104-126	8.0	50.0	0.6	N/A	8.60	10.60	15
							1.0	9.60	11.60	15
	1	208-230/60/1	197-254	3.7	22.0	0.5	N/A	4.20	5.13	15
							0.8	5.00	5.93	15
	8	265/60/1	239-292	3.5	22.0	0.4	N/A	3.90	4.78	15
							0.7	4.60	5.48	15
HRC12	0	115/60/1	104-126	9.5	50.0	1.0	N/A	10.50	12.88	20
							1.4	11.90	14.28	20
	1	208-230/60/1	197-254	4.7	25.0	0.6	N/A	5.30	6.48	15
							1.07	6.37	7.55	15
	8	265/60/1	239-292	4.2	22.0	0.4	N/A	4.60	5.65	15
							1.3	5.90	6.95	15
HRC15	1	208-230/60/1	197-254	5.6	29.0	0.7	N/A	6.30	7.70	15
							1.07	7.37	8.77	15
	8	265/60/1	239-292	5.0	28.0	0.6	N/A	5.60	6.85	15
							1.3	6.90	8.15	15
HRC18	1	208-230/60/1	197-254	6.6	33.0	0.7	N/A	7.30	8.95	15
							1.07	8.37	10.02	15
	8	265/60/1	239-292	5.6	28.0	0.6	N/A	6.20	7.60	15
							1.3	7.50	8.90	15

Table 5: HRC Electrical Data (50Hz)

Model	Voltage Code	Voltage	Min/Max Voltage	Compressor			Fan Motor FLA	Total Unit FLA	Min Circuit Amps	Max Fuse/HACR
				QTY	RLA	LRA				
HRC09	V	220-240/50/1	198-264	1	3.2	17	0.4	3.6	4.4	15.0
HRC12	V	220-240/50/1	198-264	1	4.0	19	0.4	4.4	5.4	15.0
HRC15	V	220-240/50/1	198-264	1	4.7	23	0.6	5.3	6.5	15.0
HRC18	V	220-240/50/1	198-264	1	5.6	25	0.6	6.2	7.6	15.0

Figure 3: Typical Field Installed Wiring

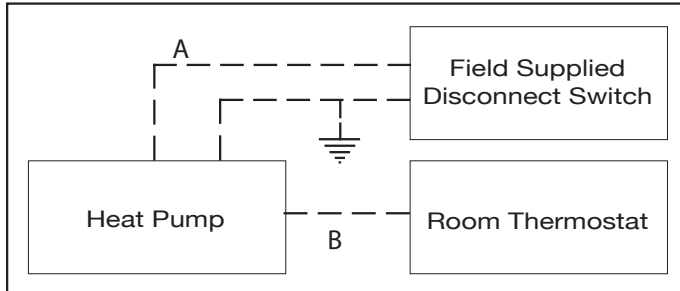

A= Two power wires on single-phase units; three power wires on three-phase units. B= 1 heat /1 cool /manual or Auto Change-over remote 24V thermostat. Note: All customer-supplied wiring to be copper only and must conform to NEC and local electrical codes. Wiring shown with dashed lines must be field-supplied and field-installed. "B" only required with systems employing remote mounted thermostats.

Low Water Temperature Cutout Setting - CXM Control
When antifreeze is selected, the LT1 jumper (JW3) should be clipped to select the low temperature (antifreeze 10.0°F [-12.2°C]) setpoint and avoid nuisance faults (see "Low Water Temperature Cutout Selection" in this manual). Note: Low water temperature operation requires extended range equipment.

⚠ WARNING! ⚠

WARNING! To avoid possible injury or death due to electrical shock, open the power supply disconnect switch and secure it in an open position during installation.

⚠ CAUTION! ⚠

CAUTION! Use only copper conductors for field installed electrical wiring. Unit terminals are not designed to accept other types of conductors.

Figure 4: LT1 Limit Setting

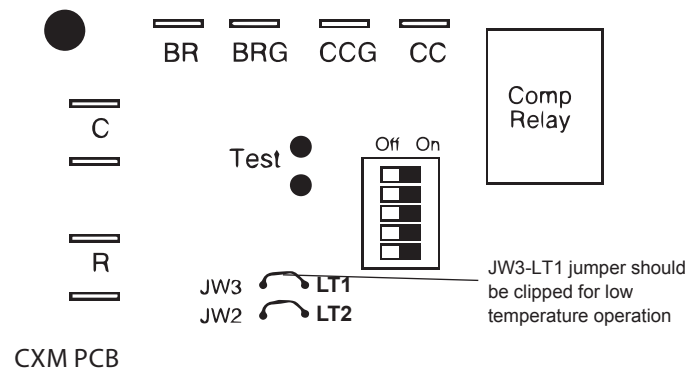

Unit-Mounted Control Models include digital display unit-mounted auto changeover (ACO) control. (see Fig. 5).

Figure 5: ACO Thermostat

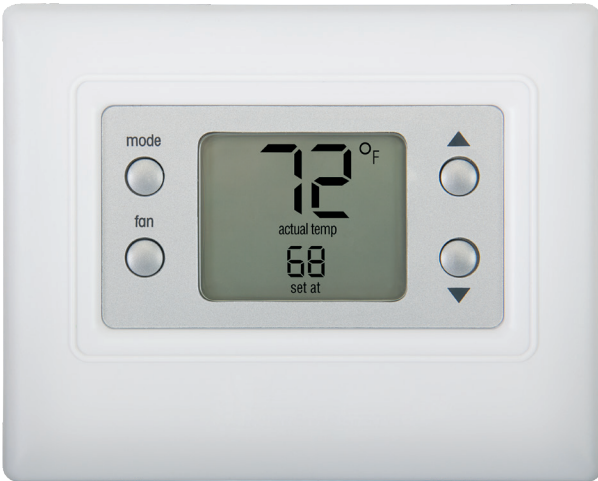

To Change Mode - push mode button to toggle through heat only, cool only, auto, off. Stop where desired.

To Adjust Setpoint - push up arrow for temperature increase or down arrow for temperature decrease. Stop where desired.

To Select Fan Operation/Speed - push fan button to toggle through fan on low, fan on hi, fan auto lo, and fan auto hi. Stop where desired. ON is continuous and Auto cycles fan with compressor.

To Configure Thermostat - for temperature reading in Fahrenheit or Celsius and backlight on/off.

Temperature reading - Press and hold mode button for 3-5 seconds.

Screen will flash U1 with °F or °C below. Press and release mode button °F or °C will flash. Use down arrow to change to °C. Use up arrow to change to °F.

Press fan button to escape.

Backlight - Press and hold mode button for 3-5 seconds.

Screen will flash U1 press up arrow and screen will change to U2 flashing. Press and release mode button and on will flash. To turn off push down arrow, push up arrow to get back to on.

Press fan button to escape.

Thermostat has advanced features to be changed by qualified installer only (do not use code 99- to restore factory default settings, reset each code if needed.)

To enter advanced mode push and hold fan button for 10-15 seconds. Use mode and arrow buttons to make selections.

Code 02 is sensor selection : rS is remote (default) DO NOT CHANGE.

Code 07 is delay: off - timeguard enabled (default); on-timeguard disabled. DO NOT CHANGE.

Code 11 is deadband between auto heat and cool: 1 through 10 for °F or °C (5 default).

Code 15 is auto or manual: On is auto (default); of is manual.

Code 21 is keypad lock: user has full access (default); 1 only access to setpoints; cd entire keypad is locked.

Code 26 is minimum cooling setpoint: 55°F to 90°F (60°F default).
[12 °C to 32 °C (50 °C default)]

Code 27 is maximum heating setpoint: 50°F to 90°F (85°F default).
[10 °C to 32 °C (29 °C default)]

Thermostat has additional codes - DO NOT CHANGE.

Figure 6: Display

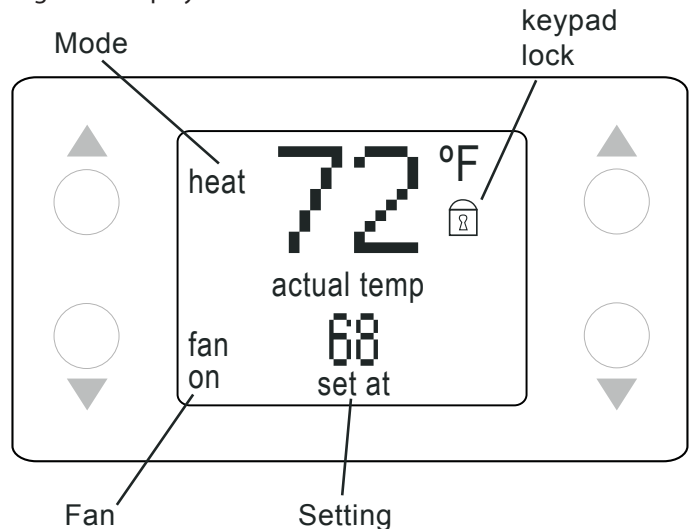

Optional Wall-Mounted Thermostat

HRC WSHP units (Model digit 8 is C, D, F, or K) are built with standard internal thermostat that has automatic changeover (ACO) configuration. No external, field-installed low-voltage wiring is required.

When desired, the unit can be furnished with a 24-volt control circuit which is field-wired to a Comfort-Aire/Century-supplied accessory remote thermostat.

Low-voltage wiring between the unit and the wall thermostat must comply with all applicable electrical codes (i.e., NEC and local codes), and be completed before the unit is installed.

Table 6: Recommended Thermostat Wire Sizes

Wire Size	Maximum Wire Length*
18-Gauge	75 feet [22m]
16-Gauge	125 feet [38m]
14-Gauge	200 feet [60 m]

*Length = Physical distance from thermostat to unit.

Thermostat Installation - The thermostat should be located on an interior wall in a larger room, away from supply air drafts. DO NOT locate the thermostat in areas subject to sunlight, drafts or on external walls. The wire access hole behind the thermostat may in certain cases need to be sealed to prevent erroneous temperature measurement. Position the thermostat back plate against the wall so that it appears level and so the thermostat wires protrude through the middle of the back plate. Mark the position of the back plate mounting holes and drill holes with a 3/16" (5mm) bit. Install supplied anchors and secure plate to the wall. Thermostat wire must be 18 AWG wire. Wire the appropriate thermostat as shown in Figure 7 to the low voltage terminal strip on the CXM or DXM control board. Practically any heat pump thermostat will work with Comfort-Aire/Century units, provided it has the correct number of heating and cooling stages.

Zone integrity must be maintained to efficiently control units or groups of units. Unless zones of control are considered and accounted for, adjacent units may operate in heating and cooling modes simultaneously, to prevent units with DXM can be wired per figure 7A.

Figure 7: Typical Remote Thermostat Wiring

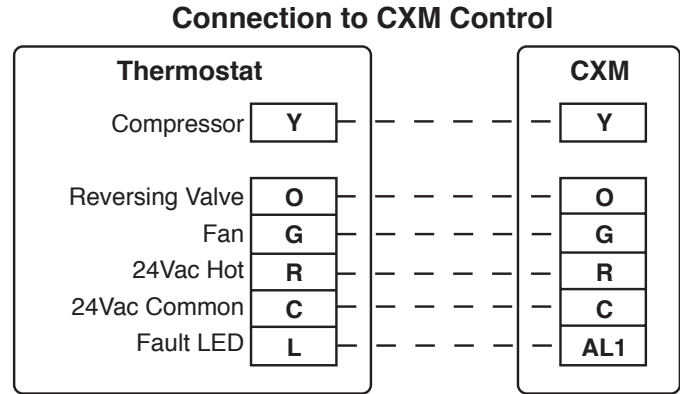

Note: If ATA11U03 is used must jumper G and G2

Figure 7a: Wiring for multiple units to be controlled from 1 thermostat

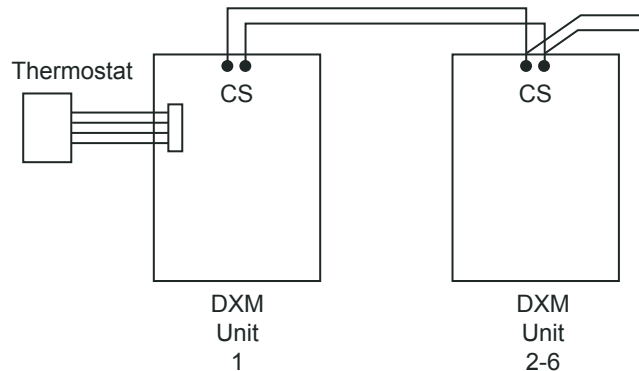

Connect thermostat to Unit 1 then jumper Com 1 (S to S and C to C) up to 6 units with twisted pair.

HRC Series Wiring Diagram Matrix

Model	Refrigerant	Wiring Diagram Part Number	Electrical V-Hz-Ph	Control		Agency
HRC09-HRC18	R410A	96B0292N01	115-60-1, 208/230-60-1, 265-60-1	CXM	ACO/MCO	ETL
	R410A	96B0292N02			REM	ETL
	R410A	96B0292N03			LON	ETL
	R410A	96B0292N04			MPC	ETL
	R410A	96B0293N01	115-60-1, 208/230-60-1, 265-60-1	DXM	ACO/MCO	ETL
	R410A	96B0293N02			REM	ETL
	R410A	96B0293N03			LON	ETL
	R410A	96B0293N04			MPC	ETL
	R410A	96B0292N05	220/240-50-1	CXM	ACO/MCO	CE
	R410A	96B0292N06			REM	CE
	R410A	96B0292N07			LON	CE
	R410A	96B0292N08			MPC	CE
	R410A	96B0293N05		DXM	MCO/ACO	CE
	R410A	96B0293N06			REM	CE
	R410A	96B0293N07			LON	CE
	R410A	96B0293N08			MPC	CE

DIP Setting for Board

<p>HRC DIGIT 8 = C,R + CXM Standard</p> <p>S1</p>	<p>HRC DIGIT 8 = D,S + DXM Standard</p> <p>S1 S2</p>
<p>HRC DIGIT 8 = L,N + CXM w/LON or MPC</p> <p>S1</p>	<p>HRC DIGIT 8 = M,P + DXM w/LON or MPC</p> <p>S1 S2</p>

CXM Controls

CXM Control - For detailed control information, see CXM Application, Operation and Maintenance (AOM) manual (part # 97B0003N12).

Field Selectable Inputs - Test mode: Test mode allows the service technician to check the operation of the control in a timely manner. At board, momentarily shorting the test terminals or externally, momentarily push test button (See Fig 22), the CXM control enters a 20 minute test mode period in which all time delays are sped up 15 times. Upon entering test mode, the status LED will flash a code representing the last fault. For diagnostic ease at the thermostat, the alarm relay will also cycle during test mode. The alarm relay will cycle on and off similar to the status LED to indicate a code representing the last fault, at the thermostat. Test mode can be exited by shorting the test terminals or holding button for 3 seconds.

Retry Mode: If the control is attempting a retry of a fault, the status LED will slow flash (slow flash = one flash every 2 seconds) to indicate the control is in the process of retrying.

Field Configuration Options - Note: In the following field configuration options, jumper wires should be clipped **ONLY** when power is removed from the CXM control.

Water coil low temperature limit setting: Jumper 3 (JW3-LT1 Low Temp) provides field selection of temperature limit setting for LT1 of 30°F or 10°F [-1°F or -12°C] (refrigerant temperature).

Not Clipped = 30°F [-1°C]. Clipped = 10°F [-12°C].

Air coil low temperature limit setting: Jumper 2 (JW2-LT2 Low Temp) provides field selection of temperature limit setting for LT2 of 30°F or 10°F [-1°F or -12°C] (refrigerant temperature). Note: This jumper should only be clipped under extenuating circumstances, as recommended by the factory.

Not Clipped = 30°F [-1°C]. Clipped = 10°F [-12°C].

Alarm relay setting: Jumper 1 (JW1-AL2 Dry) provides field selection of the alarm relay terminal AL2 to be jumpered to 24VAC or to be a dry contact (no connection).

Not Clipped = AL2 connected to R. Clipped = AL2 dry contact (no connection).

DIP Switches - Note: In the following field configuration options, DIP switches should only be changed when power is removed from the CXM control.

DIP switch 1: Unit Performance Sentinel Disable - provides field selection to disable the UPS feature.

On = Enabled. Off = Disabled.

DIP switch 2: Stage 2 Selection - provides selection of whether compressor has an “on” delay. If set to stage 2, the compressor will have a 3 second delay before energizing. Also, if set for stage 2, the alarm relay will NOT cycle during test mode.

On = Stage 1. Off = Stage 2

DIP switch 3: Not Used.

DIP switch 4: DDC Output at EH2 - provides selection for DDC operation. If set to “DDC Output at EH2,” the EH2 terminal will continuously output the last fault code of the controller. If set to “EH2 normal,” EH2 will operate as standard electric heat output.

On = EH2 Normal. Off = DDC Output at EH2.

Note: Some CXM controls only have a 2 position DIP switch package. If this is the case, this option can be selected by clipping the jumper which is in position 4 of SW1.

Jumper not clipped = EH2 Normal. Jumper clipped = DDC Output at EH2.

DIP switch 5: Factory Setting - Normal position is “On.” Do not change selection unless instructed to do so by the factory.

Table 7a: LED And Alarm Relay Operations

Description of Operation	LED	Alarm
Normal Mode	ON	Open
Normal Mode w/UPS Warning	ON	Cycle (Closed 5 seconds, Open 25 seconds)
CXM is non-functional	OFF	Open
Fault Retry	Slow Flash	Open
Lockout	Fast Flash	Closed
Over/Under Voltage Shutdown	Slow Flash	Open (Closed after 15 Minutes)
Test Mode - No Fault in Memory	Flashing Code 1	Cycling Code 1
Test Mode - HP Fault in Memory	Flashing Code 2	Cycling Code 2
Test Mode - LP Fault in Memory	Flashing Code 3	Cycling Code 3
Test Mode - LT1 Fault in Memory	Flashing Code 4	Cycling Code 4
Test Mode - LT2 Fault in Memory	Flashing Code 5	Cycling Code 5
Test Mode - CO Fault in Memory	Flashing Code 6	Cycling Code 6
Test Mode - Over/Under Shutdown in Memory	Flashing Code 7	Cycling Code 7
Test Mode - UPS in Memory	Flashing Code 8	Cycling Code 8
Test Mode - Swapped Thermistor	Flashing Code 9	Cycling Code 9

-Slow Flash = 1 flash every 2 seconds

-Fast Flash = 2 flashes every 1 second

-Flash code 2 = 2 quick flashes, 10 second pause, 2 quick flashes, 10 second pause, etc.

-On pulse 1/3 second; off pulse 1/3 second

DXM Control - For detailed control information, see DXM AOM (part #97B0003N13), Lon controller AOM (part #97B0013N01) or MPC AOM (part # 97B0031N01).

Table 7b: DXM LED And Alarm Relay Operations

Description of Operation	Status LED (green)	Test LED (yellow)	Fault LED (red)	Alarm Relay
Normal mode	On	-	Off	Open
Normal mode with UPS	On	-	Flashing Code 8	Cycle (closed 5 sec, open 25 sec)
DXM is non-functional	Off	Off	Off	Open
Fault Retry	Slow Flash	-	Flashing fault code	Open
Lockout	Fast Flash	-	Flashing fault code	Closed
Test Mode	-	On	-	-
Night Setback	Flashing Code 2	-	-	-
ESD	Flashing Code 3	-	-	-
Invalid T-stat Inputs	Flashing Code 4	-	-	-
HP Fault	Slow Flash	-	Flashing Code 2	Open
LP Fault	Slow Flash	-	Flashing Code 3	Open
LT1 Fault	Slow Flash	-	Flashing Code 4	Open
LT2 Fault	Slow Flash	-	Flashing Code 5	Open
CO Fault	Slow Flash	-	Flashing Code 6	Open
Over/Under Voltages	Slow Flash	-	Flashing Code 7	Open (closed after 15 minutes)

- Slow Flash = 1 flash every 2 seconds
- Fast Flash = 2 flashes every 1 second
- Flash code 2 = 2 quick flashes, 10 second pause, 2 quick flashes, 10 second pause, etc.
- On pulse 1/3 second; off pulse 1/3 second

Field Selectable Inputs - Test mode: Test mode allows the service technician to check the operation of the control in a timely manner. By momentarily shorting the test terminals, the DXM control enters a 20 minute test mode period in which all time delays are sped up 15 times. Upon entering test mode, the status LED will flash a code representing the last fault. For diagnostic ease at the thermostat, the alarm relay will also cycle during test mode. The alarm relay will cycle on and off similar to the status LED to indicate a code representing the last fault, at the thermostat. Test mode can be exited by shorting the test terminals for 3 seconds.

Retry mode: If the control is attempting a retry of a fault, the status LED will slow flash (slow flash = one flash every 2 seconds) to indicate the control is in the process of retrying.

Field Configuration Options - Note: In the following field configuration options, jumper wires should be clipped ONLY when power is removed from the DXM control.

Water coil low temperature limit setting: Jumper 3 (JW3-LT1 Low Temp) provides field selection of temperature limit setting for LT1 of 30°F or 10°F [-1°F or -12°C] (refrigerant temperature).

Not Clipped = 30°F [-1°C]. Clipped = 10°F [-12°C].

Air coil low temperature limit setting: Jumper 2 (JW2-LT2 Low Temp) provides field selection of temperature limit setting for LT2 of 30°F or 10°F [-1°F or -12°C] (refrigerant temperature).

Note: This jumper should only be clipped under extenuating circumstances, as recommended by Enertech technical services.

Not Clipped = 30°F [-1°C]. Clipped = 10°F [-12°C].

Alarm relay setting: Jumper 4 (JW4-AL2 Dry) provides field selection of the alarm relay terminal AL2 to be jumpered to 24VAC or to

- be a dry contact (no connection).
- Not Clipped = AL2 connected to R.
- Clipped = AL2 dry contact (no connection).

Low pressure normally open: Jumper 1 (JW1-LP norm open) provides field selection for low pressure input to be normally closed or normally open.
Not Clipped = LP normally closed. Clipped = LP normally open.

DIP Switches - Note: In the following field configuration options, DIP switches should only be changed when power is removed from the DXM control.

DIP Package #1 (S1) - DIP Package #1 has 8 switches and provides the following setup selections:
1.1 - Unit Performance Sentinel (UPS) disable: DIP Switch 1.1 provides field selection to disable the UPS feature. On = Enabled. Off = Disabled.
1.2 - Compressor relay staging operation: DIP 1.2 provides selection of compressor relay staging operation. The compressor relay can be selected to turn on with a stage 1 or stage 2 call from the thermostat. This is used with dual stage units (2 compressors where 2 DXM controls are being used) or with master/slave applications. In master/slave applications, each compressor and fan will stage according to its appropriate DIP 1.2 setting. If set to stage 2, the compressor will have a 3 second on-delay before

energizing during a Stage 2 demand. Also, if set for stage 2, the alarm relay will NOT cycle during test mode.

On = Stage 1. Off = Stage 2.

1.3 - Thermostat type (heat pump or heat/cool): DIP 1.3 provides selection of thermostat type. Heat pump or heat/cool thermostats can be selected. When in heat/cool mode, Y1 is the input call for cooling stage 1; Y2 is the input call for cooling stage 2; W1 is the input call for heating stage 1; and O/W2 is the input call for heating stage 2. In heat pump mode, Y1 is the input call for compressor stage 1; Y2 is the input call for compressor stage 2; W1 is the input call for heating stage 3 or emergency heat; and O/W2 is the input call for reversing valve (heating or cooling, depending upon DIP 1.4).

On = Heat Pump. Off = Heat/Cool.

1.4 - Thermostat type (O/B): DIP 1.4 provides selection of thermostat type for reversing valve activation. Heat pump thermostats with "O" output (reversing valve energized for cooling) or "B" output (reversing valve energized for heating) can be selected with DIP 1.4.

On = HP stat with "O" output for cooling. Off = HP stat with "B" output for heating.

1.5 - Dehumidification mode: DIP 1.5 provides selection of normal or dehumidification fan mode. In dehumidification mode, the fan speed relay will remain off during cooling stage 2. In normal mode, the fan speed relay will turn on during cooling stage 2.

On = Normal fan mode. Off = Dehumidification mode.

1.6 - DDC output at EH2: DIP 1.6 provides selection for DDC operation. If set to "DDC Output at EH2," the EH2 terminal will continuously output the last fault code of the controller. If set to "EH2 normal," EH2 will operate as standard electric heat output.

On = EH2 Normal. Off = DDC Output at EH2.

1.7 - Boilerless operation: DIP 1.7 provides selection of boilerless operation. In boilerless mode, the compressor is only used for heating when LT1 is above the temperature specified by the setting of DIP 1.8. Below DIP 1.8 setting, the compressor is not used and the control goes into emergency heat mode, staging on EH1 and EH2 to provide heating.

On = normal. Off = Boilerless operation.

1.8 - Boilerless changeover temperature: DIP 1.8 provides selection of boilerless changeover temperature setpoint. Note that the LT1 thermistor is sensing refrigerant temperature between the coaxial heat exchanger and the expansion device (TXV). Therefore, the 50°F [10°C] setting is not 50°F [10°C] water, but approximately 60°F [16°C] EWT.

On = 50°F [10°C]. Off = 40°F [16°C].

DIP Package #2 (S2) - DIP Package #2 has 8 switches and provides the following setup selections:

2.1 - Accessory1 relay personality: DIP 2.1 provides selection of ACC1 relay personality (relay operation/ characteristics). See table 5c for description of functionality.

2.2 - Accessory1 relay personality: DIP 2.2 provides selection of ACC 1 relay personality (relay operation/ characteristics). See table 5c for description of functionality.

2.3 - Accessory1 relay personality: DIP 2.3 provides selection of ACC 1 relay options. See table 5c for description of functionality.

2.4 - Accessory2 relay personality: DIP 2.4 provides selection of ACC 2 relay personality (relay operation/ characteristics). See table 5c for description of functionality.

2.5 - Accessory2 relay personality: DIP 2.5 provides selection of ACC 2 relay personality (relay operation/ characteristics). See table 5c for description of functionality.

2.6 - Accessory2 relay personality: DIP 2.6 provides selection of ACC 2 relay options. See table 5c for description of functionality.

2.7 - Auto dehumidification fan mode or high fan mode: DIP 2.7 provides selection of auto dehumidification fan mode or high fan mode. In auto dehumidification mode, the fan speed relay will remain off during cooling stage 2 IF the H input is active. In high fan mode, the fan enable and fan speed relays will turn on when the H input is active.

On = Auto dehumidification mode. Off = High fan mode.

2.8 - Special factory selection: DIP 2.8 provides special factory selection. Normal position is "On". Do not change selection unless instructed to do so by the factory.

Table 7c: Accessory DIP Switch Settings

DIP 2.1	DIP 2.2	DIP 2.3	ACC1 Relay Option
On	On	On	Cycle with fan
Off	On	On	Digital NSB
On	Off	On	Water Valve - slow opening
On	On	Off	OAD
Off	Off	Off	Reheat Option - Humidistat
Off	On	Off	Reheat Option - Dehumidistat
DIP 2.4	DIP 2.5	DIP 2.6	ACC2 Relay Option
On	On	On	Cycle with compressor
Off	On	On	Digital NSB
On	Off	On	Water Valve - slow opening
On	On	Off	OAD

All other DIP combinations are invalid

Safety Features - CXM/DXM Controls

Safety Features – CXM/DXM Control - The safety features below are provided to protect the compressor, heat exchangers, wiring and other components from damage caused by operation outside of design conditions.

Anti-short cycle protection: The control features a 5 minute anti-short cycle protection for the compressor. Note: The 5 minute anti-short cycle also occurs at power up.

Random start: The control features a random start upon power up of 5-80 seconds.

Fault Retry: In Fault Retry mode, the Status LED begins slowly flashing to signal that the control is trying to recover from a fault input. The control will stage off the outputs and then “try again” to satisfy the thermostat input call. Once the thermostat input call is satisfied, the control will continue on as if no fault occurred. If 3 consecutive faults occur without satisfying the thermostat input call, the control will go into “lockout” mode. The last fault causing the lockout will be stored in memory and can be viewed at the “fault” LED (DXM board) or by going into test mode (CXM board). Note: LT1/LT2 faults are factory set at only one try.

Lockout: In lockout mode, the status LED will begin fast flashing. The compressor relay is turned off immediately. Lockout mode can be “soft” reset by turning off the thermostat (or satisfying the call). A “soft” reset keeps the fault in memory but resets the control. A “hard” reset (disconnecting power to the control) resets the control and erases fault memory.

Lockout with emergency heat: While in lockout mode, if W becomes active (CXM), emergency heat mode will occur. If DXM is configured for heat pump thermostat type (DIP 1.3), emergency heat will become active if O/W2 is energized.

High pressure switch: When the high pressure switch opens due to high refrigerant pressures, the compressor relay is de-energized immediately since the high pressure switch is in series with the compressor contactor coil. The high pressure fault recognition is immediate (does not delay for 30 continuous seconds before de-energizing the compressor).

High pressure lockout code = 2

Example: 2 quick flashes, 10 sec pause, 2 quick flashes, 10 sec. pause, etc.

Low pressure switch: The low pressure switch must be open and remain open for 30 continuous seconds during “on” cycle to be recognized as a low pressure fault. If the low pressure switch is open for 30 seconds prior to compressor power up it will be considered a low pressure (loss of charge) fault. The low pressure switch input is bypassed for the initial 120 seconds of a compressor run cycle.

Low pressure lockout code = 3

Water coil low temperature (LT1): The LT1 thermistor temperature must be below the selected low temperature limit setting for 30 continuous seconds during a compressor run cycle to be recognized as a LT1 fault. The LT1 input is bypassed for the initial 120 seconds of a compressor run cycle. LT1 is set at the factory for one try. Therefore, the control will go into lockout mode once the LT1 fault has occurred.

LT1 lockout code = 4

Air coil low temperature (LT2): The LT2 thermistor temperature must be below the selected low temperature limit setting for 30 continuous seconds during a compressor run cycle to be recognized as a LT2 fault. The LT2 input is bypassed for the initial 60 seconds of a compressor run cycle. LT2 is set at the factory for one try. Therefore, the control will go into lockout mode once the LT2 fault has occurred.

LT2 lockout code = 5

Condensate overflow: The condensate overflow sensor must sense overflow level for 30 continuous seconds to be recognized as a CO fault. Condensate overflow will be monitored at all times.

CO lockout code = 6

Over/under voltage shutdown: An over/under voltage condition exists when the control voltage is outside the range of 19VAC to 30VAC. Over/under voltage shutdown is a self-resetting safety. If the voltage comes back within range for at least 0.5 seconds, normal operation is restored. This is not considered a fault or lockout. If the CXM/DXM is in over/under voltage shutdown for 15 minutes, the alarm relay will close.

Over/under voltage shut down code = 7

Unit Performance Sentinel-UPS (patent pending): The UPS feature indicates when the heat pump is operating inefficiently. A UPS condition exists when:

- a. In heating mode with compressor energized, LT2 is greater than 125°F [52°C] for 30 continuous seconds, or:
- b. In cooling mode with compressor energized, LT1 is greater than 125°F [52°C] for 30 continuous seconds, or:
- c. In cooling mode with compressor energized, LT2 is less than 40°F [4.5°C] for 30 continuous seconds.

If a UPS condition occurs, the control will immediately go to UPS warning. The status LED will remain on as if the control is in normal mode. Outputs of the control, excluding LED and alarm relay, will NOT be affected by UPS. The UPS condition cannot occur during a compressor off cycle. During UPS warning, the alarm relay will cycle on and off. The cycle rate will be "on" for 5 seconds, "off" for 25 seconds, "on" for 5 seconds, "off" for 25 seconds, etc.

UPS warning code = 8

Swapped LT1/LT2 thermistors: During test mode, the control monitors to see if the LT1 and LT2 thermistors are in the appropriate places. If the control is in test mode, the control will lockout with code 9 after 30 seconds if:

- a. The compressor is on in the cooling mode and the LT1 sensor is colder than the LT2 sensor, or:
- b. The compressor is on in the heating mode and the LT2 sensor is colder than the LT1 sensor.

Swapped LT1/LT2 thermistor code = 9.

ESD (DXM only): The ESD (Emergency Shut Down) mode can be enabled from an external common signal to terminal ESD to shut down the unit. The green status light will flash code 3 when the unit is in ESD mode.

ESD mode = code 3 (green "status" LED)

CXM/DXM CONTROLS

Diagnostic Features - The LED on the CXM board advises the technician of the current status of the CXM control. The LED can display either the current CXM mode or the last fault in memory if in test mode. If there is no fault in memory, the LED will flash Code 1 (when in test mode).

The green status LED and red fault LED on the DXM board advise the technician of the current status of the DXM control. The status LED will indicate the current mode that the DXM control is in. The fault LED will ALWAYS flash a code representing the LAST fault in memory. If there is no fault in memory, the fault LED will flash Code 1. The yellow test LED will turn on when in test mode. CAUTION: Do not restart units without inspection and remedy of faulting condition. Damage may occur.

CXM/DXM Control Start-up Operation - The control will not operate until all inputs and safety controls are checked for normal conditions. The compressor will have a 5 minute anti-short cycle delay at power-up. The first time after power-up that there is a call for compressor, the compressor will follow a 5 to 80 second random start delay. After the random start delay and anti-short cycle delay, the compressor relay will be energized. On all subsequent compressor calls, the random start delay is omitted.

Unit Commissioning and Operating Conditions

Environment - This unit is designed for indoor installation only. Do not install in an area subject to freezing or where humidity levels can cause cabinet condensation.

Power Supply - A voltage variation of +/- 10% of nameplate utilization voltage is acceptable.

Operation and performance is primarily dependent upon return air temperature, airflow, water temperature, water flow rate and ambient air temperature. This water to air heat pump is capable of operating over a wide temperature range and with flow rates of between 1.5 GPM (.1 l/s) and 3 GPM (.19 l/s) per ton, however usually no more than one of these factors may be at a minimum or maximum level at a time.

Table 8: Building Commissioning

BUILDING COMMISSIONING		
	ALL HRC MODELS	
	Cooling °F [°C]	Heating °F [°C]
AMBIENT MIN - MAX DB	45-110 [7-43]	40-85 [4.5-29]
RETURN AIR MIN DB/WB	60/45 [16/7]	40 [4.5]
RETURN AIR MAX DB/WB	110/83 [43/28]	80 [27]
STANDARD UNIT ENTERING WATER MIN* - MAX	40-120 [4.5-49]	60-90 [16-43]
EXTENDED RANGE UNIT** ENTERING WATER MIN* - MAX	30-120 [-1-49]	20-90 [-6.7-32]

*- Requires optional insulation package when operating below the dew point

** - Requires antifreeze, optional insulation package and jumper clipped.

Table 8A: Unit Operating Limits

UNIT OPERATING LIMITS		
	All HRC Models	
	Cooling °F [°C]	Heating °F [°C]
AMBIENT MIN - MAX DB	50-100 [10-38]	50-85 [10-29]
RETURN AIR MIN DB/WB	65/60 [18/15.5]	50 [10]
RETURN AIR MAX DB/WB	95/75 [35/24]	80 [27]
STANDARD UNIT ENTERING WATER MIN* - MAX	50-120 [10-49]	60-90 [16-43]
EXTENDED RANGE UNIT** ENTERING WATER MIN* - MAX	30-120 [-1-49]	20-90 [-6.7-32]

*- Requires optional insulation package when operating below the dew point

** - Requires antifreeze, optional insulation package and jumper clipped.

The commissioning table indicates air and water temperatures which are suitable for initial unit commissioning in an environment where the flow rate and water temperature is not yet stable and to avoid nuisance shut down of the units freeze and refrigerant pressure safeties.

The operating table indicates the maximum and minimum ranges of the unit.

For more specific unit performance reference the product catalog, the submittal data sheets or contact your supplier for assistance.

Table 9: Water Temperature Change Through Heat Exchanger

Water Flow, gpm (l/m)	Rise, Cooling °F (°C)	Drop, Heating °F (°C)
For Closed Loop: Ground Source or Closed Loop Systems at 3 gpm per ton (3.9 l/m per kw)	9 - 12 (5 - 6.7)	4 - 8 (2.2 - 4.4)
For Open Loop: Ground Water Systems at 1.5 gpm per ton (2.0 l/m per kw)	20 - 26 (11.1 - 14.4)	10 - 17 (5.6 - 9.4)

Piping System Cleaning and Flushing

Piping System Cleaning and Flushing - Cleaning and flushing the WLHP piping system is the single most important step to ensure proper start-up and continued efficient operation of the system.

Follow the instructions below to properly clean and flush the system:

1. Ensure that electrical power to the unit is disconnected.
2. Install the system with the supply hose connected directly to the return riser valve. Use a single length of flexible hose.
3. Open all air vents. Fill the system with water. DO NOT allow system to overflow. Bleed all air from the system. Pressurize and check the system for leaks and repair as appropriate.
4. Verify that all strainers are in place (Comfort-Aire/Century recommends a strainer with a #20 stainless steel wire mesh). Start the pumps, and systematically check each vent to ensure that all air is bled from the system.
5. Verify that make-up water is available. Adjust make-up water as required to replace the air which was bled from the system. Check and adjust the water/air level in the expansion tank.
6. Set the boiler to raise the loop temperature to approximately 86°F [30°C]. Open a drain at the lowest point in the system. Adjust the make-up water replacement rate to equal the rate of bleed.
7. Refill the system and add trisodium phosphate in a proportion of approximately one pound per 150 gallons [1/2 kg per 750 l] of water (or other equivalent approved cleaning agent). Reset the boiler to raise the loop temperature to 100°F [38°C]. Circulate the solution for a minimum of 8 to 24 hours. At the end of this period, shut off the circulating pump and drain the solution. Repeat system cleaning if desired.
8. When the cleaning process is complete, remove the short-circuited hoses. Reconnect the hoses to the proper supply, and return the connections to each of the units. Refill the system and bleed off all air.
9. Test the system pH with litmus paper. The system water should be in the range of pH 6.0 - 8.5 (see table 3). Add chemicals, as appropriate to maintain neutral pH levels.
10. When the system is successfully cleaned, flushed, refilled and bled, check the main system panels, safety cutouts and alarms. Set the controls to properly maintain loop temperatures.

DO NOT use "Stop Leak" or similar chemical agent in this system. Addition of chemicals of this type to the loop water will foul the heat exchanger and inhibit unit operation.

⚠ CAUTION! ⚠

CAUTION! To avoid possible damage to a plastic (PVC) piping system, do not allow temperatures to exceed 110°F (43°C).

Note: The manufacturer strongly recommends all piping connections, both internal and external to the unit, be pressure tested by an appropriate method prior to any finishing of the interior space or before access to all connections is limited. Test pressure may not exceed the maximum allowable pressure for the unit and all components within the water system. The manufacturer will not be responsible or liable for damages from water leaks due to inadequate or lack of a pressurized leak test, or damages caused by exceeding the maximum pressure rating during installation.

Unit and System Checkout Procedure

⚠ WARNING! ⚠

WARNING! Polyolester Oil, commonly known as POE oil, is a synthetic oil used in many refrigeration systems including those with HFC-410A refrigerant. POE oil, if it ever comes in contact with PVC or CPVC piping, may cause failure of the PVC/CPVC. PVC/CPVC piping should never be used as supply or return water piping with water source heat pump products containing HFC-410A as system failures and property damage may result.

BEFORE POWERING SYSTEM, please check the following:

UNIT CHECKOUT

- Balancing/shutoff valves: Insure that all isolation valves are open and water control valves are wired.
- Line voltage and wiring: Verify that voltage is within an acceptable range for the unit and wiring and fuses/breakers are properly sized. Verify that low voltage wiring is complete.
- Unit control transformer: Insure that transformer has the properly selected voltage tap. Commercial 208-230V units are factory wired for 208V operation unless specified otherwise.
- Entering water and air: Insure that entering water and air temperatures are within operating limits of Table 8.
- Low water temperature cutout: Verify that low water temperature cut-out on the CXM/DXM control is properly set.
- Unit fan: Manually rotate fan to verify free rotation and insure that blower wheel is secured to the motor shaft. Be sure to remove any shipping supports if needed. DO NOT oil motors upon start-up. Fan motors are pre-oiled at the factory. Check unit fan speed selection and compare to design requirements.
- Condensate line: Verify that condensate line is open and properly pitched toward drain.
- Water flow balancing: Record inlet and outlet water temperatures for each heat pump upon startup. This check can eliminate nuisance trip outs and high velocity water flow that could erode heat exchangers.
- Unit air coil and filters: Insure that filter is clean and accessible. Clean air coil of all manufacturing oils.
- Unit controls: Verify that CXM or DXM field selection options are properly set.

SYSTEM CHECKOUT

- System water temperature: Check water temperature for proper range and also verify heating and cooling set points for proper operation.
- System pH: Check and adjust water pH if necessary to maintain a level between 6 and 8.5. Proper pH promotes longevity of hoses and fittings (see Table 3).
- System flushing: Verify that all hoses are connected end to end when flushing to insure that debris bypasses the unit heat exchanger, water valves and other components. Water used in the system must be potable quality initially and clean of dirt, piping slag, and strong chemical cleaning agents. Verify that all air is purged from the system. Air in the system can cause poor operation or system corrosion.
- Cooling tower/boiler: Check equipment for proper set points and operation.
- Standby pumps: Verify that the standby pump is properly installed and in operating condition.
- System controls: Verify that system controls function and operate in the proper sequence.
- Low water temperature cutout: Verify that low water temperature cut-out controls are provided for the outdoor portion of the loop. Otherwise, operating problems may occur.
- System control center: Verify that the control center and alarm panel have appropriate set points and are operating as designed.
- Miscellaneous: Note any questionable aspects of the installation.

⚠ CAUTION! ⚠

CAUTION! Verify that ALL water control valves are open and allow water flow prior to engaging the compressor. Freezing of the coax or water lines can permanently damage the heat pump.

⚠ CAUTION! ⚠

CAUTION! To avoid equipment damage, DO NOT leave system filled in a building without heat during the winter unless antifreeze is added to the water loop. Heat exchangers never fully drain by themselves and will freeze unless winterized with antifreeze.

NOTICE! Failure to remove shipping brackets from spring-mounted compressors will cause excessive noise, and could cause component failure due to added vibration.

Unit Start-Up Procedure

Unit Start-up Procedure

1. Turn the thermostat fan position to "ON". Blower should start.
2. Balance air flow at registers.
3. Adjust all valves to their full open positions. Turn on the line power to all heat pumps.
4. Room temperature should be within the minimum-maximum ranges of table 8. During start-up checks, loop water temperature entering the heat pump should be between 60°F [16°C] and 95°F [35°C].
5. Two factors determine the operating limits of Comfort-Aire/Century heat pumps, (a) return air temperature, and (b) water temperature. When any one of these factors is at a minimum or maximum level, the other factor must be at normal level to insure proper unit operation.
 - a. Adjust the unit thermostat to the warmest setting. Place the thermostat mode switch in the "COOL" position. Slowly reduce thermostat setting until the compressor activates.
 - b. Check for cool air delivery at the unit grille within a few minutes after the unit has begun to operate.

Note: Units have a five minute time delay in the control circuit that can be eliminated on the CXM/DXM control board as shown below in Figure 8. See controls description for details.

- c. Check the elevation and cleanliness of the condensate lines. Dripping may be a sign of a blocked line. Check that the condensate trap is filled to provide a water seal.
 - d. Refer to Table 9. Check the temperature of both entering and leaving water. If temperature is within range, proceed with the test. If temperature is outside of the operating range, check refrigerant pressures.
 - e. Check air temperature drop across the air coil when compressor is operating. Air temperature drop should be between 15°F and 25°F [8°C and 14°C].
 - f. Turn thermostat to "OFF" position. A hissing noise indicates proper functioning of the reversing valve.
6. Allow five (5) minutes between tests for pressure to equalize before beginning heating test.
 - a. Adjust the thermostat to the lowest setting. Place the thermostat mode switch in the "HEAT" position.
 - b. Slowly raise the thermostat to a higher temperature until the compressor activates.
 - c. Check for warm air delivery within a few minutes after the unit has begun to operate.

- d. Refer to Table 9. Check the temperature of both entering and leaving water. If temperature is within range, proceed with the test. If temperature is outside of the operating range, check refrigerant pressures.
 - e. Check air temperature rise across the air coil when compressor is operating. Air temperature rise should be between 20°F and 30°F [11°C and 17°C].
 - f. Check for vibration, noise, and water leaks.
7. If unit fails to operate, perform troubleshooting analysis (see troubleshooting section). If the check described fails to reveal the problem and the unit still does not operate, contact a trained service technician to insure proper diagnosis and repair of the equipment.
8. When testing is complete, set system to maintain desired comfort level.
9. BE CERTAIN TO FILL OUT AND FORWARD ALL WARRANTY REGISTRATION PAPERS TO Comfort-Aire/Century.

Note: If performance during any mode appears abnormal, refer to the CXM/DXM section or troubleshooting section of this manual. To obtain maximum performance, the air coil should be cleaned before start-up. A 10% solution of dishwasher detergent and water is recommended.

⚠ WARNING ⚠

WARNING! When the disconnect switch is closed, high voltage is present in some areas of the electrical panel. Exercise caution when working with energized equipment.

⚠ CAUTION! ⚠

CAUTION! Verify that ALL water control valves are open and allow water flow prior to engaging the compressor. Freezing of the coax or water lines can permanently damage the heat pump.

Figure 8: Test Mode Pins

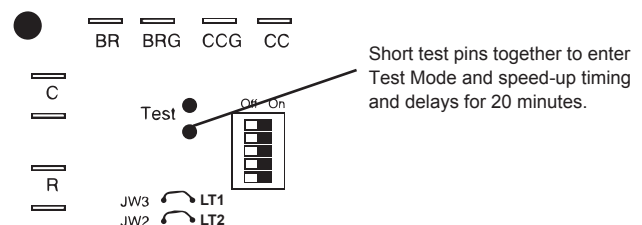

Unit Operating Conditions

NOTE: Table 10 includes the following notes:

- Airflow is at nominal (rated) conditions;
- Entering air is based upon 70°F [21°C] DB in heating and 80/67°F [27/19°C] in cooling;
- Subcooling is based upon head pressure at compressor service port;
- Cooling air and water values can vary greatly with changes in humidity level.

Table: 10 HRC Series Typical Operating Pressures and Temperatures (60 Hz I-P Units)

HRC09		Full Load Cooling						Full Load Heating					
Entering Water Temp °F	Water Flow GPM/Ton	Suction Pressure PSIG	Discharge Pressure PSIG	Super-heat	Sub-cooling	Water Temp Rise °F	Air Temp Drop °F DB	Suction Pressure PSIG	Discharge Pressure PSIG	Super-heat	Sub-cooling	Water Temp Drop °F	Air Temp Rise °F DB
30	1.4	126-136	161-181	17-22	8-13	19.8-21.8	21-27	74-84	278-298	6-11	4-9	6.1-8.1	18-24
	2	126-136	146-166	17-22	7-12	14.9-16.9	21-27	77-87	280-300	6-11	4-9	4.5-6.5	18-24
	2.75	126-136	131-151	17-22	6-11	9.9-11.9	21-27	79-89	283-303	6-11	3-8	2.8-4.8	19-25
50	1.4	132-142	215-235	10-15	8-13	18.8-20.8	20-26	104-114	309-329	8-12	7-12	9.6-11.6	24-30
	2	132-142	200-220	10-15	7-12	14.4-16.1	20-26	106-116	312-332	8-12	7-12	7-9	24-30
	2.75	132-142	185-205	10-15	6-11	9.4-11.4	20-26	108-118	315-335	8-12	7-12	4.5-6.5	25-31
70	1.4	138-148	278-298	8-13	9-14	17.7-19.7	19-25	127-137	332-352	10-15	10-15	12-14	29-35
	2	138-148	263-283	8-13	8-13	13.1-15.1	19-25	132-142	340-360	11-16	10-15	9-10	29-35
	2.75	137-147	248-268	8-13	7-12	8.5-10.5	19-25	138-148	341-367	13-18	10-15	6.1-8.1	30-36
90	1.4	142-152	365-385	8-13	9-14	16-18	18-24	164-174	372-392	17-22	13-18	14.5-16.5	35-41
	2	142-152	351-371	8-13	8-13	12-14	18-24	165-175	375-395	18-23	13-18	11.2-13.2	35-41
	2.75	142-152	337-357	8-13	7-12	8-10	18-24	167-177	379-399	19-24	13-18	7.9-9.9	36-42
110	1.4	150-160	439-459	7-12	9-14	14.2-16.2	17-23						
	2	150-160	439-459	7-12	8-13	10.6-12.6	17-23						
	2.75	150-160	439-459	7-12	7-12	6.9-8.9	17-23						

HRC12		Full Load Cooling						Full Load Heating					
Entering Water Temp °F	Water Flow GPM/Ton	Suction Pressure PSIG	Discharge Pressure PSIG	Super-heat	Sub-cooling	Water Temp Rise °F	Air Temp Drop °F DB	Suction Pressure PSIG	Discharge Pressure PSIG	Super-heat	Sub-cooling	Water Temp Drop °F	Air Temp Rise °F DB
30	1.75	98-108	140-160	36-41	14-19	17.1-19.1	19-25	72-82	301-321	9-14	12-17	6.5-8.5	21-27
	2.6	98-108	135-155	36-41	12-17	12.5-14.5	19-25	85-95	304-324	9-14	12-17	4.7-6.7	21-27
	3.5	99-109	127-148	36-41	10-15	7.9-9.9	19-25	78-88	308-328	9-14	12-17	2.9-4.9	22-28
50	1.75	118-128	215-235	22-27	14-19	18.1-20.1	20-26	100-110	337-357	10-15	15-20	9.5-11.5	26-32
	2.6	118-128	200-220	22-27	12-17	13.1-15.1	20-26	98-108	334-354	10-15	15-20	6.6-8.6	26-32
	3.5	118-128	185-205	22-27	10-15	8.1-10.1	19-25	95-105	332-352	11-16	15-20	3.8-5.8	26-32
70	1.75	132-142	300-320	11-16	12-17	17-19	19-25	115-125	361-381	19-24	18-23	11.1-13.1	29-35
	2.6	132-142	263-282	11-16	10-15	12.6-14.6	19-25	112-122	360-380	20-25	18-23	8-10	29-35
	3.5	132-142	245-265	12-17	7-12	8.2-10.2	19-25	110-120	356-376	21-26	18-23	4.8-6.8	29-35
90	1.75	138-148	366-386	9-14	11-16	15.8-17.8	18-24	122-132	376-396	34-39	22-27	12.1-14.1	32-38
	2.6	138-148	353-373	9-14	9-14	14.9-16.9	18-24	123-133	378-398	36-41	22-27	9-11	32-38
	3.5	138-148	340-360	9-14	6-11	14-16	18-24	124-134	380-400	38-43	23-28	5.8-7.8	32-38
110	1.75	145-155	453-473	9-14	9-14	14.7-16.7	16-22						
	2.6	145-155	442-462	9-14	7-12	10.8-12.8	16-22						
	3.5	145-155	431-451	9-14	5-10	6.8-8.8	17-23						

Unit Operating Conditions

Table: 10 HRC Series Typical Operating Pressures and Temperatures (60 Hz I-P Units)

HRC15		Full Load Cooling						Full Load Heating					
Entering Water Temp °F	Water Flow GPM/ton	Suction Pressure PSIG	Discharge Pressure PSIG	Super-heat	Sub-cooling	Water Temp Rise °F	Air Temp Drop °F DB	Suction Pressure PSIG	Discharge Pressure PSIG	Super-heat	Sub-cooling	Water Temp Drop °F	Air Temp Rise °F DB
30	2.1	98-108	140-160	36-41	14-19	17.1-19.1	19-25	74-84	278-298	6-11	4-9	6.1-8.1	18-24
	3.15	98-108	135-155	36-41	12-17	12.5-14.5	19-25	77-87	280-300	6-11	4-9	4.5-6.5	18-24
	4.2	99-109	127-148	36-41	10-15	7.9-9.9	19-25	79-89	283-303	6-11	3-8	2.8-4.8	19-25
50	2.1	118-128	215-235	22-27	14-19	18.1-20.1	20-26	104-114	309-329	8-12	7-12	9.6-11.6	24-30
	3.15	118-128	200-220	22-27	12-17	13.1-15.1	20-26	106-116	312-332	8-12	7-12	7-9	24-30
	4.2	118-128	185-205	22-27	10-15	8.1-10.1	19-25	108-118	315-335	8-12	7-12	4.5-6.5	25-31
70	2.1	132-142	300-320	11-16	12-17	17-19	19-25	127-137	332-352	10-15	10-15	12-14	29-35
	3.15	132-142	263-282	11-16	10-15	12.6-14.6	19-25	132-142	340-360	11-16	10-15	9-10	29-35
	4.2	132-142	245-265	12-17	7-12	8.2-10.2	19-25	138-148	347-367	13-18	10-15	6.1-8.1	30-36
90	2.1	138-148	366-386	9-14	11-16	15.8-17.8	18-24	164-174	372-392	17-22	13-18	14.5-16.5	35-41
	3.15	138-148	353-373	9-14	9-14	14.9-16.9	18-24	165-175	375-395	18-23	13-18	11.2-13.2	35-41
	4.2	138-148	340-360	9-14	6-11	14-16	18-24	167-177	379-399	19-24	13-18	7.9-9.9	36-42
110	2.1	145-155	453-473	9-14	9-14	14.7-16.7	16-22						
	3.15	145-155	442-462	9-14	7-12	10.8-12.8	16-22						
	4.2	145-155	431-451	9-14	5-10	6.8-8.8	17-23						

HRC18		Full Load Cooling						Full Load Heating					
Entering Water Temp °F	Water Flow GPM/ton	Suction Pressure PSIG	Discharge Pressure PSIG	Super-heat	Sub-cooling	Water Temp Rise °F	Air Temp Drop °F DB	Suction Pressure PSIG	Discharge Pressure PSIG	Super-heat	Sub-cooling	Water Temp Drop °F	Air Temp Rise °F DB
30	2.5	98-108	140-160	36-41	14-19	17.1-19.1	19-25	74-84	278-298	6-11	4-9	6.1-8.1	18-24
	3.75	98-108	135-155	36-41	12-17	12.5-14.5	19-25	77-87	280-300	6-11	4-9	4.5-6.5	18-24
	5	99-109	127-148	36-41	10-15	7.9-9.9	19-25	79-89	283-303	6-11	3-8	2.8-4.8	19-25
50	2.5	118-128	215-235	22-27	14-19	18.1-20.1	20-26	104-114	309-329	8-12	7-12	9.6-11.6	24-30
	3.75	118-128	200-220	22-27	12-17	13.1-15.1	20-26	106-116	312-332	8-12	7-12	7-9	24-30
	5	118-128	185-205	22-27	10-15	8.1-10.1	19-25	108-118	315-335	8-12	7-12	4.5-6.5	25-31
70	2.5	132-142	300-320	11-16	12-17	17-19	19-25	127-137	332-352	10-15	10-15	12-14	29-35
	3.75	132-142	263-282	11-16	10-15	12.6-14.6	19-25	132-142	340-360	11-16	10-15	9-10	29-35
	5	132-142	245-265	12-17	7-12	8.2-10.2	19-25	138-148	347-367	13-18	10-15	6.1-8.1	30-36
90	2.5	138-148	366-386	9-14	11-16	15.8-17.8	18-24	164-174	372-392	17-22	13-18	14.5-16.5	35-41
	3.75	138-148	353-373	9-14	9-14	14.9-16.9	18-24	165-175	375-395	18-23	13-18	11.2-13.2	35-41
	5	138-148	340-360	9-14	6-11	14-16	18-24	167-177	379-399	19-24	13-18	7.9-9.9	36-42
110	2.5	145-155	453-473	9-14	9-14	14.7-16.7	16-22						
	3.75	145-155	442-462	9-14	7-12	10.8-12.8	16-22						
	5	145-155	431-451	9-14	5-10	6.8-8.8	17-23						

Table 11: Coax Water Pressure Drop

Model	GPM	Pressure Drop, PSI				PD Added for Motorized Water Valve
		30°F	50°F	70°F	90°F	
HRC09	1.1	1.6	1.2	1.0	0.9	0.3
	1.6	2.6	2.2	2.0	1.9	0.6
	2.3	4.5	3.8	3.5	3	1.2
HRC12	1.5	2.1	1.8	1.5	1.3	0.5
	2.3	4.5	3.8	3.5	3	1.2
	3	6.8	5.8	4.9	4.5	2.2
HRC15	1.9	1.5	1	0.9	0.8	0.7
	2.8	3	2.3	2	1.7	1.7
	3.7	4.7	3.9	3.3	2.9	3.3
HRC18	2.3	2.2	1.8	1.5	1.3	0.2
	3.4	4.4	3.8	3.4	3	0.6
	4.5	6.9	6	5.2	4.8	1.1

Installer: Complete unit and system checkout and follow unit start-up procedures in the IOM. Use this form to record unit information, temperatures and pressures during start-up. Keep this form for future reference.

Job Name: _____ **Street Address:** _____

Model Number: _____ **Serial Number:** _____

Unit Location in Building: _____

Date: _____ **Sales Order No:** _____

In order to minimize troubleshooting and costly system failures, complete the following checks and data entries before the system is put into full operation.

Temperatures: F or C
Pressures: PSIG or kPa

Antifreeze: _____ %
Type _____

	Cooling Mode	Heating Mode
Return-Air Temperature DB		
Supply-Air Temperature DB		
Temperature Differential		
Entering Fluid Temperature		
Leaving Fluid Temperature		
Temperature Differential		
Water Coil Heat Exchanger (Water Pressure IN)		
Water Coil Heat Exchanger (Water Pressure OUT)		
Pressure Differential		
Flow Rate GPM (l/s)		
Supply Voltage at Contactor		
Transformer Low Side Volts		
Compressor Amps		
Motor Amps		

Allow unit to run 15 minutes in each mode before taking data.

Do not connect service manifold gauges during start up unless instructed by Comfort-Aire/Century service tech.

Preventive Maintenance

Water Coil Maintenance -

(Direct ground water applications only)

If the system is installed in an area with a known high mineral content (125 P.P.M. or greater) in the water, it is best to establish a periodic maintenance schedule with the owner so the coil can be checked regularly. Consult the well water applications section of this manual for a more detailed water coil material selection. Should periodic coil cleaning be necessary, use standard coil cleaning procedures, which are compatible with the heat exchanger material and copper water lines. Generally, the more water flowing through the unit, the less chance for scaling. Therefore, 1.5 gpm per ton [2.0 l/m per kW] is recommended as a minimum flow. Minimum flow rate for entering water temperatures below 50°F [10°C] is 2.0 gpm per ton [2.6 l/m per kW].

Water Coil Maintenance -

(All other water loop applications)

Generally water coil maintenance is not needed for closed loop systems. However, if the piping is known to have high dirt or debris content, it is best to establish a periodic maintenance schedule with the owner so the water coil can be checked regularly. Dirty installations are typically the result of deterioration of iron or galvanized piping or components in the system. Open cooling towers requiring heavy chemical treatment and mineral buildup through water use can also contribute to higher maintenance. Should periodic coil cleaning be necessary, use standard coil cleaning procedures, which are compatible with both the heat exchanger material and copper water lines. Generally, the more water flowing through the unit, the less chance for scaling. However, flow rates over 3 gpm per ton (3.9 l/m per kW) can produce water (or debris) velocities that can erode the heat exchanger wall and ultimately produce leaks.

Filters - Filters must be clean to obtain maximum performance. Filters should be inspected every month under normal operating conditions and be replaced when necessary. Units should never be operated without a filter.

Washable, high efficiency, electrostatic filters, when dirty, can exhibit a very high pressure drop for the fan motor and reduce air flow, resulting in poor performance. It is especially important to provide consistent washing of these filters (in the opposite direction of the normal air flow) once per month using a high pressure wash similar to those found at self-serve car washes.

Condensate Drain - In areas where airborne bacteria may produce a "slimy" substance in the drain pan, it may be necessary to treat the drain pan chemically with an algaecide approximately every three months to minimize the problem. The condensate pan may also need to be cleaned periodically to insure indoor air quality. The condensate drain can pick up lint and dirt, especially with dirty filters. Inspect the drain twice a year to avoid the possibility of plugging and eventual overflow.

Compressor - Conduct annual amperage checks to insure that amp draw is no more than 10% greater than indicated on the serial plate data.

Fan Motors - All units have lubricated fan motors. Fan motors should never be lubricated unless obvious, dry operation is suspected. Periodic maintenance oiling is not recommended, as it will result in dirt accumulating in the excess oil and cause eventual motor failure. Conduct annual dry operation check and amperage check to insure amp draw is no more than 10% greater than indicated on serial plate data.

Air Coil - The air coil must be cleaned to obtain maximum performance. Check once a year under normal operating conditions and, if dirty, brush or vacuum clean. Care must be taken not to damage the aluminum fins while cleaning. CAUTION: Fin edges are sharp.

Cabinet - Do not allow water to stay in contact with the cabinet for long periods of time to prevent corrosion of the cabinet sheet metal. The cabinet can be cleaned using a mild detergent.

Refrigerant System - To maintain sealed circuit integrity, do not install service gauges unless unit operation appears abnormal. Reference the operating charts for pressures and temperatures. Verify that air and water flow rates are at proper levels before servicing the refrigerant circuit.

Fault	Htg	Clg	Possible Cause	Solution		
Main power problems	X	X	Green Status LED Off	Check line voltage circuit breaker and disconnect.		
				Check for line voltage between L1 and L2 on the contactor.		
				Check for 24VAC between R and C on CXM/DXM2		
HP Fault Code 2 High Pressure		X	Reduced or no water flow in cooling	Check pump operation or valve operation/setting. Check water flow adjust to proper flow rate.		
			Water Temperature out of range in cooling	Bring water temp within design parameters.		
	X		Reduced or no air flow in heating	Check for dirty air filter and clean or replace.		
				Check fan motor operation and airflow restrictions.		
				Dirty Air Coil- construction dust etc.		
	X		Air temperature out of range in heating	Too high of external static. Check static vs blower table. Bring return air temp within design parameters.		
	X	X	Overcharged with refrigerant	Check superheat/subcooling vs typical operating condition table.		
X	X	Bad HP Switch	Check switch continuity and operation. Replace.			
LP/LOC Fault Code 3 Low Pressure / Loss of Charge	X	X	Insufficient charge	Check for refrigerant leaks		
				X		Compressor pump down at start-up
LT1 Fault Code 4 Water coil low temperature limit	X		Reduced or no water flow in heating	Check pump operation or water valve operation/setting. Plugged strainer or filter. Clean or replace.. Check water flow adjust to proper flow rate.		
			X		Inadequate antifreeze level	Check antifreeze density with hydrometer.
			X		Improper temperature limit setting (30°F vs 10°F [-1°C vs -2°C])	Clip JW3 jumper for antifreeze (10°F [-12°C]) use.
	X		Water Temperature out of range	Bring water temp within design parameters.		
	X	X	Bad thermistor	Bring water temp within design parameters. Check temp and impedance correlation per chart		
LT2 Fault Code 5 Air coil low temperature limit		X	Reduced or no air flow in cooling	Check for dirty air filter and clean or replace. Check fan motor operation and airflow restrictions. Too high of external static. Check static vs blower table.		
			X		Air Temperature out of range	Too much cold vent air? Bring entering air temp within design parameters.
	X	X	Improper temperature limit setting (30°F vs 10°F [-1°C vs -12°C])	Normal airside applications will require 30°F [-1°C] only.		
	X	X	Bad thermistor	Check temp and impedance correlation per chart.		
Condensate Fault Code 6	X	X	Blocked drain	Check for blockage and clean drain.		
			X	X	Improper trap	Check trap dimensions and location ahead of vent. Check for piping slope away from unit. Check slope of unit toward outlet. Poor venting. Check vent location.
		X	Poor drainage	Poor venting. Check vent location.		
				Check for moisture shorting to air coil.		
	X	X	Plugged air filter	Replace air filter.		
	X	X	Restricted Return Air Flow	Find and eliminate restriction. Increase return duct and/or grille size. Check power supply and 24VAC voltage before and during operation.		
Over/Under Voltage Code 7 (Auto resetting)	X	X	Under Voltage	Check power supply wire size. Check compressor starting. Need hard start kit? Check 24VAC and unit transformer tap for correct power supply voltage.		
			X	X	Over Voltage	Check power supply voltage and 24VAC before and during operation. Check 24VAC and unit transformer tap for correct power supply voltage.
	X		Heating mode LT2>125°F [52°C]	Check for poor air flow or overcharged unit.		
Unit Performance Sentinel Code 8		X	Cooling Mode LT1>125°F [52°C] OR LT2<40°F [4°C]	Check for poor water flow, or air flow.		
Swapped Thermistor Code 9	X	X	LT1 and LT2 swapped	Reverse position of thermistors		
No Fault Code Shown	X	X	No compressor operation	See "Only Fan Operates".		
			Compressor overload	Check and replace if necessary.		
			Control board	Reset power and check operation.		
Unit Short Cycles	X	X	Dirty air filter	Check and clean air filter.		
			Unit in "test mode"	Reset power or wait 20 minutes for auto exit.		
			Unit selection	Unit may be oversized for space. Check sizing for actual load of space.		
			Compressor overload	Check and replace if necessary		
Only Fan Runs	X	X	Thermostat position	Ensure thermostat set for heating or cooling operation.		
			Unit locked out	Check for lockout codes. Reset power.		
			Compressor Overload	Check compressor overload. Replace if necessary.		
			Thermostat wiring	Check thermostat wiring at heat pump. Jumper Y and R for compressor operation in test mode.		
Only Compressor Runs	X	X	Thermostat wiring	Check G wiring at heat pump. Jumper G and R for fan operation		
			X	X	Fan motor relay	Jumper G and R for fan operation. Check for Line voltage across BR contacts.
			X	X	Fan motor	Check fan power enable relay operation (if present).
			X	X	Fan motor	Check for line voltage at motor. Check capacitor.
Unit Doesn't Operate in Cooling		X	Reversing valve	Set for cooling demand and check 24VAC on RV coil and at CXM/DXM2 board. If RV is stuck, run high pressure up by reducing water flow and while operating engage and disengage RV coil voltage to push valve.		
			Thermostat setup	Check for 'O' RV setup not 'B'.		
			Thermostat wiring	Check O wiring at heat pump. Jumper O and R for RV coil 'click'.		
	X	X	Thermostat wiring	Put thermostat in cooling mode. Check 24 VAC on O (check between C and O); check for 24 VAC on W (check between W and C). There should be voltage on O, but not on W. If voltage is present on W, thermostat may be bad or wired incorrectly.		

Performance Troubleshooting

Performance Troubleshooting	Htg	Clg	Possible Cause	Solution
Insufficient capacity/ Not cooling or heating	X	X	Dirty filter	Replace or clean.
	X		Reduced or no air flow in heating	Check for dirty air filter and clean or replace.
				Check fan motor operation and airflow restrictions.
				Too high of external static. Check static vs. blower table.
		X	Reduced or no air flow in cooling	Check for dirty air filter and clean or replace.
				Check fan motor operation and airflow restrictions.
				Too high of external static. Check static vs. blower table.
	X	X	Leaky duct work	Check supply and return air temperatures at the unit and at distant duct registers if significantly different, duct leaks are present.
	X	X	Low refrigerant charge	Check superheat and subcooling per chart.
	X	X	Restricted metering device	Check superheat and subcooling per chart. Replace.
	X	X	Defective reversing valve	Perform RV touch test.
X	X	Thermostat improperly located	Check location and for air drafts behind stat.	
X	X	Unit undersized	Recheck loads & sizing. Check sensible clg. load and heat pump capacity.	
X	X	Scaling in water heat exchanger	Perform scaling check and clean if necessary.	
X	X	Inlet water too hot or too cold	Check load, loop sizing, loop backfill, ground moisture.	
High Head Pressure	X		Reduced or no air flow in heating	Check for dirty air filter and clean or replace.
				Check fan motor operation and air flow restrictions.
				Too high of external static. Check static vs. blower table.
		X	Reduced or no water flow in cooling	Check pump operation or valve operation/setting. Check water flow. Adjust to proper flow rate.
		X	Inlet water too hot	Check load, loop sizing, loop backfill, ground moisture.
	X		Air temperature out of range in heating	Bring return air temperature within design parameters.
		X	Scaling in water heat exchanger	Perform scaling check and clean if necessary.
	X	X	Unit overcharged	Check superheat and subcooling. Re-weigh in charge.
X	X	Non-condensables in system	Vacuum system and re-weigh in charge.	
X	X	Restricted metering device.	Check superheat and subcooling per chart. Replace.	
Low Suction Pressure	X		Reduced water flow in heating.	Check pump operation or water valve operation/setting.
				Plugged strainer or filter. Clean or replace.
				Check water flow. Adjust to proper flow rate.
	X		Water temperature out of range.	Bring water temperature within design parameters.
		X	Reduced air flow in cooling.	Check for dirty air filter and clean or replace. Check fan motor operation and air flow restrictions. Too high of external static. Check static vs. blower table.
		X	Air temperature out of range	Too much cold vent air? Bring entering air temperature within design parameters.
X	X	Insufficient charge	Check for refrigerant leaks.	
Low Discharge Air Temperature in Heating	X		Too high of air flow	Check fan motor speed selection and air flow chart.
	X		Poor performance	See 'Insufficient Capacity'
High humidity		X	Too high of air flow	Check fan motor speed selection and airflow chart.
		X	Unit oversized	Recheck loads & sizing. Check sensible clg load and heat pump capacity.

HEATING CYCLE ANALYSIS -

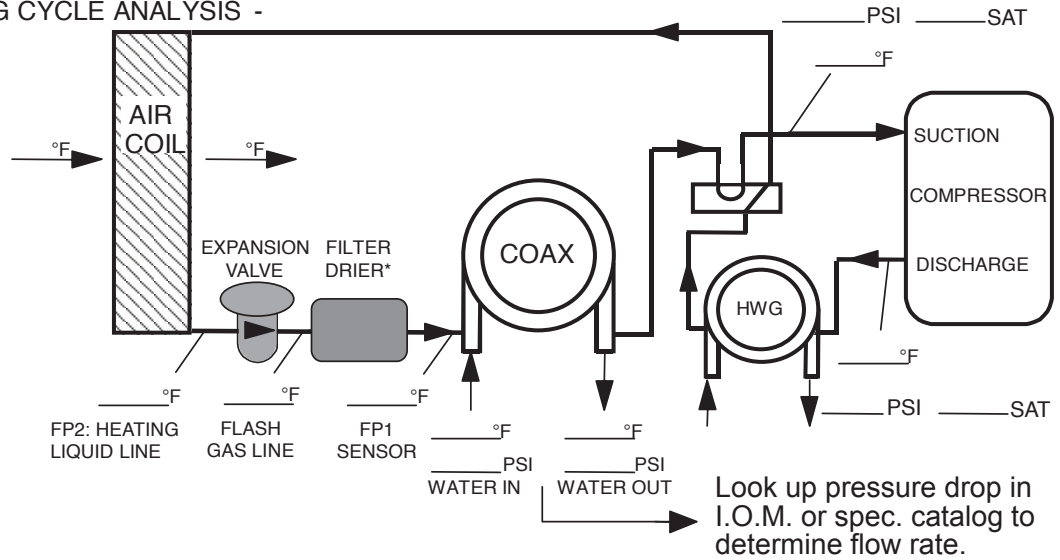

COOLING CYCLE ANALYSIS -

Refrigerant Type:

HFC-410A

Voltage: _____

Comp Amps: _____

Total Amps: _____

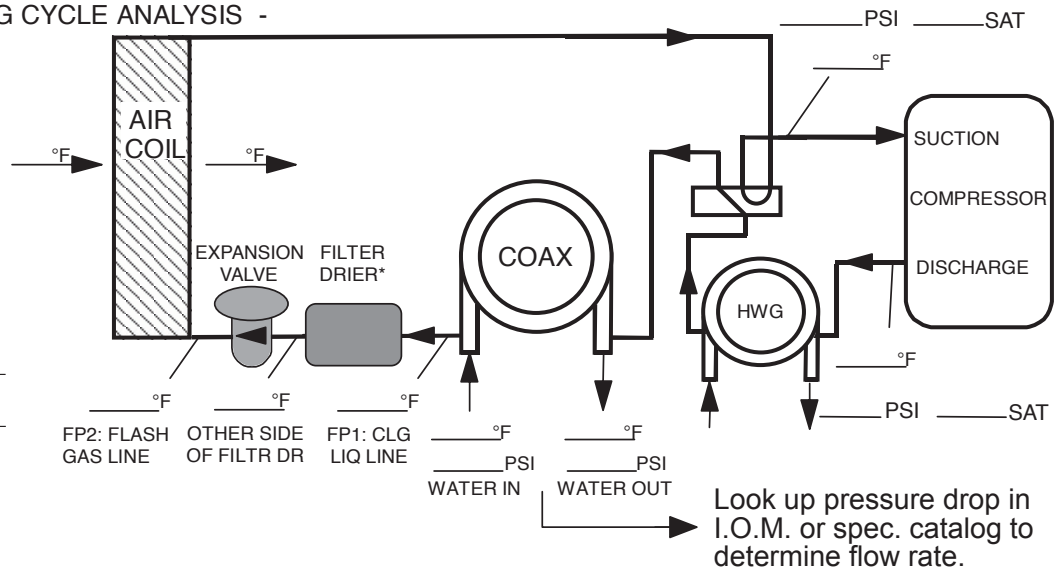

Heat of Extraction (Absorption) or Heat of Rejection =

_____ flow rate (gpm) x _____ temp.diff. (deg. F) x _____ fluid factor[†] = _____ (Btu/hr)

Superheat = Suction temperature - suction saturation temp. = _____ (deg F)

Subcooling = Discharge saturation temp. - liquid line temp. = _____ (deg F)

[†] Use 500 for water, 485 for antifreeze.

Note: Never connect refrigerant gauges during startup procedures. Conduct water-side analysis using P/T ports to determine water flow and temperature difference. If water-side analysis shows poor performance, refrigerant troubleshooting may be required. Connect refrigerant gauges as a last resort.



LIMITED EXPRESS WARRANTY - HRC SERIES WATER-SOURCE HEAT PUMP

Congratulations on purchasing your new HVAC equipment. It has been designed for long life and reliable service, and is backed by one of the strongest warranties in the industry. Your unit automatically qualifies for the warranty coverage listed below, provided you keep your proof of purchase (receipt) for the equipment and meet the warranty conditions.

GENERAL

This limited express warranty is applicable to HRC Series water-source heat pumps manufactured by Comfort-Aire/Century, and used in commercial installations.

LIMITED ONE (1) YEAR PARTS EXPRESS WARRANTY

Comfort-Aire/Century warrants all parts of the HRC water-source heat pump used in commercial applications to be free from defects in workmanship and materials for normal use and maintenance for one (1) year from the date of purchase by the original consumer for the original installation. This Express Limited Warranty applies only when the system is installed per Comfort-Aire/Century installation instructions and in accordance with all local, state and national codes for normal use.

LIMITED FIVE (5) YEAR EXPRESS WARRANTY ON COMPRESSOR

We will replace a compressor which proves to be defective for a period of five (5) years from date of heat pump purchase. All restrictions, limitations and procedures for the one year parts warranty apply to the additional compressor warranty period.

EXCEPTIONS

The Limited Express Warranty does not cover normal maintenance—Comfort-Aire/Century recommends that regular inspection/maintenance be performed at least once a season and proof of maintenance be kept. Additionally, labor charges, transportation charges for replacement parts, replacement of refrigerant or filters, any other service calls/repairs are not covered by this Limited Warranty. It also does not cover any portion or component of the system that is not supplied by Comfort-Aire/Century, regardless of the cause of failure of such portion or component.

CONDITIONS FOR WARRANTY COVERAGE

- Unit must be operated according to Comfort-Aire/Century operating instructions included with the unit and cannot have been subjected to accident, alteration, improper repair, neglect or misuse, or an act of God (such as flood)
- Serial numbers and/or rating plate have not been altered or removed
- Installation was done by a trained, licensed or otherwise qualified geothermal dealer/contractor
- Performance cannot be impaired by use of any product not authorized by Comfort-Aire/Century, or by any adjustments or adaptations to components
- Damage has not been a result of inadequate wiring or voltage conditions, use during brown-out conditions, or circuit interruptions
- Air flow around any section of the unit has not been restricted
- Unit remains in the original installation
- Unit was not purchased over the internet

DURATION OF WARRANTY & REGISTRATION

The warranty begins on the date of purchase by the original consumer. The consumer must register their product at www.marsdelivers.com within 90 days of purchase. The consumer must retain a receipted bill of sale as proof of warranty period. Without this proof, the express warranty begins on the date of shipment from the factory.

REMEDY PROVIDED BY THE LIMITED EXPRESS WARRANTY

The sole remedy under the Limited Warranty is replacement of the defective part. If replacement parts are required within the period of this warranty, Comfort-Aire/Century replacement parts shall be used; any warranty on the replacement part(s) shall not affect the applicable original unit warranty. Ready access to the unit for service is the owner's responsibility. Labor to diagnose and replace the defective part is not covered by this Limited Express Warranty. If for any reason the replacement part/product is no longer available during the warranty period, Comfort-Aire/Century shall have the right to allow a credit in the amount of the current suggested retail price of the part/product instead of providing repair or replacement.

LIMITATION OF LIABILITY

1. There are no other express or implied warranties. Comfort-Aire/Century makes no warranty of merchantability. We do not warrant that the unit is suitable for any particular purpose or can be used in buildings or rooms of any particular size or condition except as specifically provided in this document. There are no other warranties, express or implied, which extend beyond the description in this document.
2. All warranties implied by law are limited in duration to the one-term of the parts warranty. Your exclusive remedy is limited to the replacement of defective parts. **We will not be liable for any consequential or incidental damages caused by any defect in this unit.**
3. This warranty gives you specific legal rights and you may also have other rights which vary from state to state. Some states do not allow limitation on how long an implied warranty lasts or do not allow the exclusion or limitation of incidental or consequential damages, so the above limitations or exclusions may not apply to you.
4. No warranties are made for units sold outside the continental United States and Canada. Your distributor or final seller may provide a warranty on units sold outside these areas.
5. Comfort-Aire/Century will not be liable for damages if our performance regarding warranty resolution is delayed by events beyond our control including accident, alteration, abuse, war, government restrictions, strikes, fire, flood, or other acts of God.

Please follow the below steps to register your product.

- **Please log onto our website www.marsdelivers.com**
- **Resources**
- **Product Registration**
- **Complete the requested information in all caps, especially the Email Address**
- **Press the "Continue" button at the bottom**
- **A copy of the registration will be sent to the email address that you entered at the top of the page for your records**

KEEP THIS INFORMATION AS A RECORD OF YOUR PURCHASE

Apply Serial Number and Model Number sticker here (from product carton). If unavailable, write serial number and model number below (can be found on unit rating plate).

Date of Purchase _____ Date Installation Completed _____
 Component of new HVAC system Replacement heat pump only
 Remember to retain your bill of sale as proof of warranty period and ownership.



Please visit www.marsdelivers.com to register your new product

Notes

Notes

Revision History

Date:	Item:	Action:
04/19/16	Logo	Updated
04/15/16	Text	Updated
10/12/15	General Information Text; Wiring Diagram Matrix	Updated
8/24/15	Decoders, Physical Data, Wiring Diagram Matrix, and Start-Up Log Sheet	Updated
8/14/15	50 Hz Decoder & Wire Diagram Matrix	Removed CE Text
8/11/15	All	Updated
6/11/15	Unit Operating Conditions	Updated
09/23/14	50 Hz Decoders and Misc.	Updated
06/23/14	Water Quality Table	Updated
04/08/13	Electrical - Low Voltage	Added ACO T-stat
11/09/12	POE Oil Warning	Updated
	Water Quality Table	Updated
12/06/11	Removed shipping bolt, compressor isolation, plate, and spring information.	All were removed with compressor revision.
09/09/11	HRC Series Nomenclature Unit Physical Data Tables	Updated Added Optional Factory Installed Auto Flow Regulator Data
08/09/11	Unit Maximum Working Water Pressure	Updated to Reflect New Safeties
01/03/11	Format - All Pages	Updated
07/26/10	Wiring Diagrams	Updated
07/07/10	Pre-Installation	Updated
06/11/10	Format - All Pages	Updated
06/11/10	CCE (R22) Units	Removed
11/05/09	Warranty	Updated
10/30/09	Functional Troubleshooting Table	Updated
09/15/09	Safety Features - CXM/DXM Controls	Updated
07/29/09	Unit Commissioning & Operating Conditions	Data Tables Corrected
06/09/09	'Unit Starting & Operating Conditions' Section & Table	Edited and renamed 'Unit Commissioning and Operating Conditions'
12/02/08	HRC & CCE Wiring Diagrams	Consolidated
12/02/08	HRC & Piping Connection Diagrams	Added
09/09/08	Pressure Testing Note	Updated
06/30/08	Shut-Off Valve Note	Added to Piping Connections
05/21/08	Unit and System Checkout	Added Pressure testing language
05/20/08	All	Updated
01/01/07	All	Added HRC
01/01/07	Controls	Added CCE Rev B controls
01/01/07	Piping	Added warnings on pressure switches when using water solenoid valves
01/01/07	Applications	Added Notice on ground-water applications
01/01/06	First Published	

Due to ongoing product improvements, specifications and dimensions are subject to change and correction without notice or incurring obligations. Determining the application and suitability for use of any product is the responsibility of the installer. Additionally, the installer is responsible for verifying dimensional data on the actual product prior to beginning any installation preparations.

Incentive and rebate programs have precise requirements as to product performance and certification. All products meet applicable regulations in effect on date of manufacture; however, certifications are not necessarily granted for the life of a product. Therefore, it is the responsibility of the applicant to determine whether a specific model qualifies for these incentive/rebate programs.

Comfort-Aire®  Century®