

HMG60E1P

SPECIFICATIONS

Application

- 5 ton systems
- Optional field installed electric heater

Installation

- 1 piece design
- Multi-position = Upflow/Horizontal (Left/Right)/ Downflow (with kit)
- Approved for installation in manufactured housing and mobile homes

Cabinet

- Improved rubber gasketing between cabinets to prevent air leaks
- Removable panels for complete service access
- Tool-less access to filter area for quick and easy servicing
- Baked enamel finish over galvanized steel and insulated with thick fiberglass for maximum durability
- Deep, corrosion resistant plastic drain pans have dual pipes designed for upflow, downflow and horizontal applications
- 2% or less air leakage

Coils

- Enhanced tube-and-fin coil design for corrosion resistance
- Aluminum tubing, hairpins, distributor and header tubes
- Lanced fins and rifled tubing for maximum heat transfer
- Factory leak tested

Components

- Efficient constant torque ECM blower motor
- Leadless blower motor with easy plug connections

ENHANCED AIR HANDLER

*ECM Motor
Constant Torque Motor*



MODEL NUMBER GUIDE

H	M	G	60	E	1	P
DX Air Handler	Multi-Tubed Aluminum Alloy Coil	'Green' Gas R-410A	Capacity BTUH x 1000	Enhance Constant Torque Motor with TXV	Power 1 = 208/230-1-60	Series/Revision

ELECTRICAL HEAT DATA - SINGLE PHASE

Electric Heat Model Number	No. of Stages	Input			² Blower Motor Full Load Amps	³ Minimum Circuit Ampacity			⁵ Maximum Overcurrent Protection			Single Point Power Source	
		Volts	kW	¹ Btuh		CKT 1	CKT 2	CKT 3	CKT 1	CKT 2	CKT 3	³ Minimum Circuit Ampacity	⁵ Maximum Overcurrent Protection
5 kW 4 lbs. ECB27-5CB (17D47) 35A Circuit breaker	1	208	3.8	12,800	7.6	32	-	-	35	-	-	-	-
		220	4.2	14,300	7.6	36	-	-	⁴ 40	-	-	-	-
		230	4.6	15,700	7.6	36	-	-	⁴ 40	-	-	-	-
		240	5.0	17,100	7.6	36	-	-	⁴ 40	-	-	-	-
9 kW 5 lbs. ECB27-9CB (17D52) 60A Circuit breaker	2	208	6.8	23,100	7.6	50	-	-	⁴ 50	-	-	-	-
		220	7.6	25,800	7.6	56	-	-	60	-	-	-	-
		230	8.3	28,200	7.6	56	-	-	60	-	-	-	-
		240	9.0	30,700	7.6	56	-	-	60	-	-	-	-
12.5 kW 10 lbs. ECB27-12.5CB (17D53) (1) 30A Circuit breaker & (1) 45A Circuit breaker	2	208	9.4	32,000	7.6	28	38	-	30	⁴ 40	-	66	70
		220	10.5	35,800	7.6	31	43	-	⁴ 35	45	-	75	80
		230	11.5	39,200	7.6	31	43	-	⁴ 35	45	-	75	80
		240	12.5	42,600	7.6	31	45	-	⁴ 35	45	-	75	80
15 kW 12 lbs. ECB27-15CB (17D54) (1) 35A Circuit breaker & (1) 60A Circuit breaker	2	208	11.3	38,400	7.6	32	52	-	35	⁴ 45	-	77	80
		220	12.6	43,000	7.6	36	52	-	⁴ 40	60	-	88	90
		230	13.5	47,000	7.6	36	52	-	⁴ 40	60	-	88	90
		240	15.0	51,200	7.6	36	52	-	⁴ 40	60	-	88	90
20 kW 19 lbs. ECB27-20CB (17D55) (1) 60A Circuit breaker & (1) 60A Circuit breaker	2	208	15.0	51,200	7.6	50	50	-	⁴ 50	⁴ 50	-	100	125
		220	16.8	57,300	7.6	56	57	-	60	60	-	114	125
		230	18.4	62,700	7.6	56	57	-	60	60	-	114	125
		240	20.0	68,200	7.6	56	57	-	60	60	-	114	125
25 kW 19 lbs. ECB27-25CB (17D56) (1) 60A Circuit breaker & (2) 45A Circuit breaker	3	208	18.8	64,100	7.6	47	38	38	⁴ 50	⁴ 40	⁴ 40	123	125
		220	21.0	71,700	7.6	53	43	43	60	45	45	140	150
		230	23.0	78,300	7.6	53	43	43	60	45	45	140	150
		240	25.0	85,300	7.6	53	43	43	60	45	45	140	150

NOTE - Circuit 1 Minimum Circuit Ampacity includes the Blower Motor Full Load Amps.

¹. Electric heater capacity only - does not include additional blower motor heat capacity.

². Amps shown are for blower motor only

³. Refer to National or Canadian Electrical Code manual to determine wire, fuse, and disconnect size requirements. Use wires suitable for at least 167°F

⁴. Bold text indicates that the circuit breaker on "CB" circuit breaker models must be replaced with size noted.

⁵. HACR type circuit breaker or fuse.

BLOWER

External Static Pressure in. w.g.	Air Volume and Motor Watts									
	Tap 1		Tap 2		Tap 3		Tap 4		Tap 5	
	CFM	Watts	CFM	Watts	CFM	Watts	CFM	Watts	CFM	Watts
.10	1404	206	1704	340	1886	453	1928	481	2268	800
.20	1295	194	1658	349	1849	467	1905	510	2228	829
.30	1256	204	1631	365	1806	489	1869	525	2192	830
.40	1199	217	1594	386	1784	505	1842	546	2169	856
.50	1145	236	1549	394	1751	523	1799	548	2136	870
.60	1091	248	1508	413	1720	534	1775	569	2106	894
.70	978	270	1474	433	1683	549	1741	592	2089	907
.80	946	279	1440	453	1655	566	1709	611	2050	925

INSTALLATION CLEARANCES WITH ELECTRIC HEAT

CABINET	0 inch (0 mm)
TO PLENUM	1 inch (25mm)
TO OUTLET DUCT WITHIN 3 FEET (914 MM)	1 inch (25mm)
FLOOR	See Note #1
SERVICE / MAINTENANCE	See Note #2

¹ Units installed on combustible floors in the downflow position with electric heat require optional downflow combustible flooring base.

² Front service access - 24 inches (610 mm) minimum.

Note - If cabinet depth is more than 24 inches (610mm), allow a minimum of the cabinet depth plus 2 inches (51 mm).

DIMENSIONS - INCHES (MM)

UPFLOW POSITION

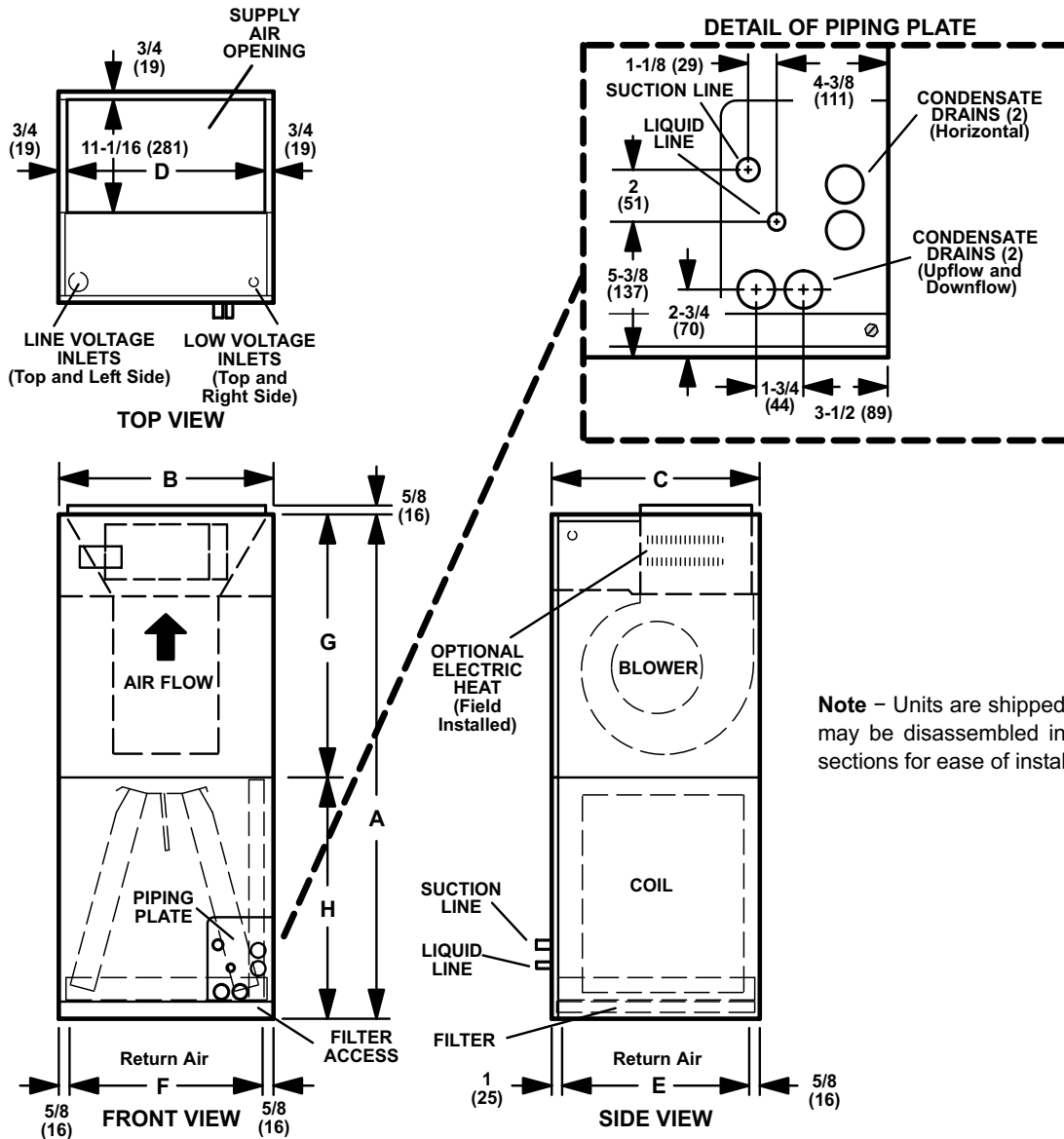

Note - Units are shipped in one piece but may be disassembled into two separate sections for ease of installation.

MODEL		A	B	C	D	E	F	G	H
HMG60E1P	in.	62-1/2	21-1/4	24-5/8	19-3/4	23	20	27-7/8	34-5/8
	mm	1588	540	625	502	584	508	708	879

DIMENSIONS - INCHES (MM)

DOWNFLOW POSITION with Optional Downflow Conversion Kit (Required)

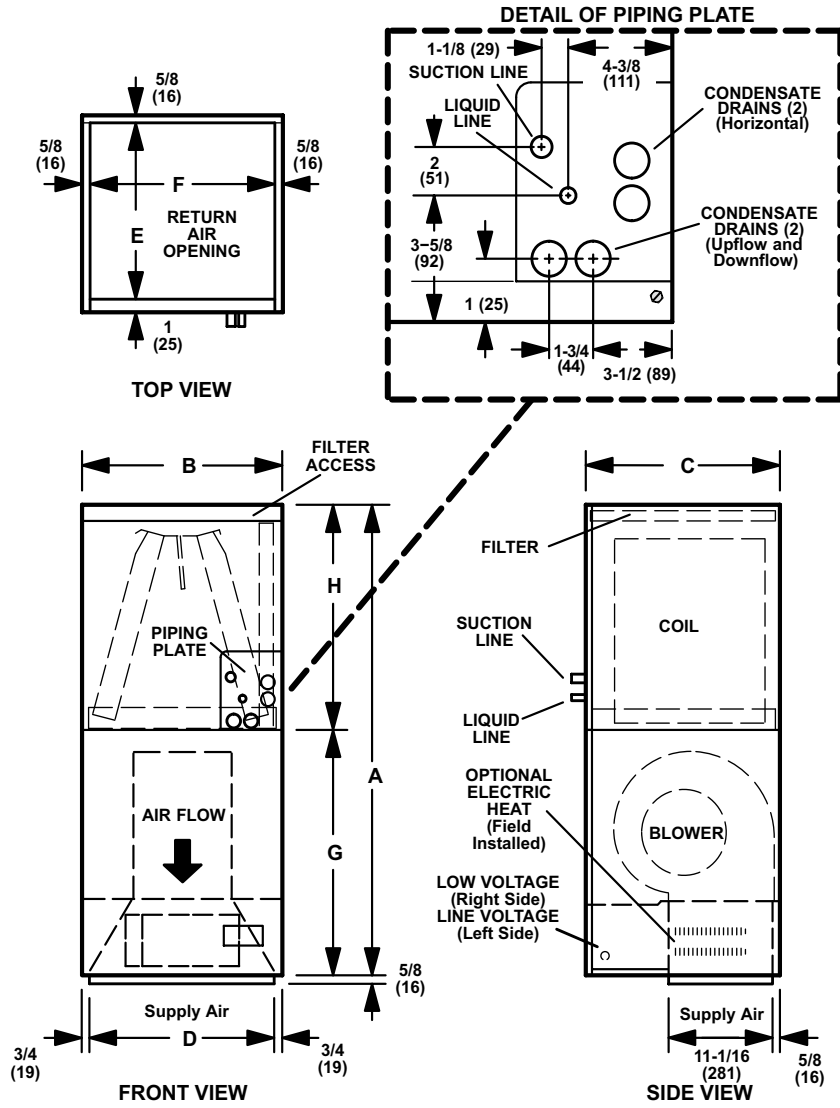

Note - Units are shipped in one piece but may be disassembled into two separate sections for ease of installation.

MODEL		A	B	C	D	E	F	G	H
HMG60E1P	in.	62-1/2	21-1/4	24-5/8	19-3/4	23	20	27-7/8	34-5/8
	mm	1588	540	625	502	584	508	708	879

DIMENSIONS - INCHES (MM)

RIGHT-HAND AIR DISCHARGE

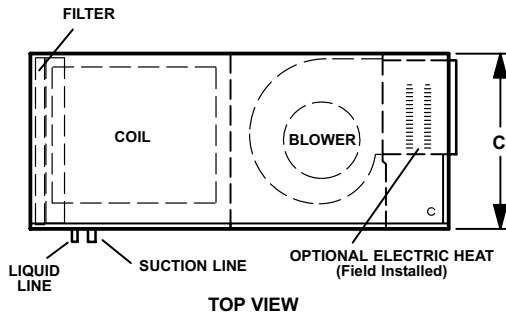
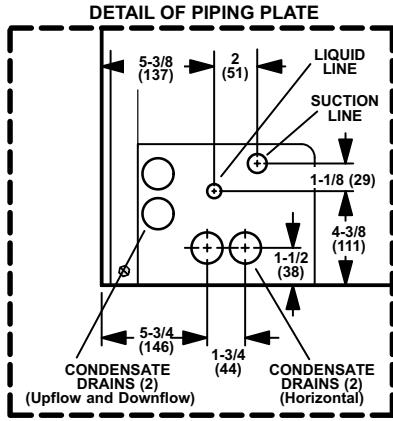

Note – Units are shipped in one piece but may be disassembled into two separate sections for ease of installation.

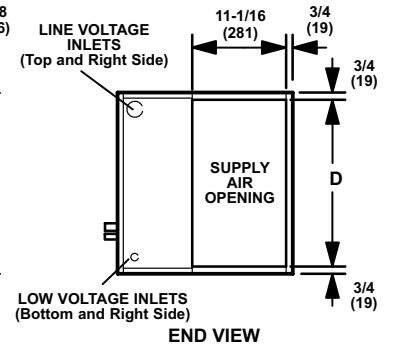
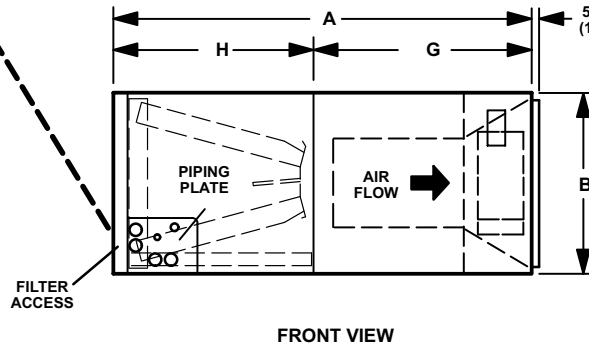
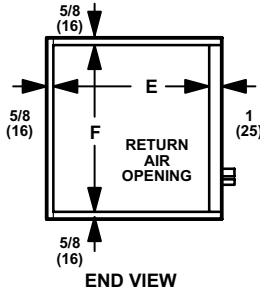

LEFT-HAND AIR DISCHARGE

Note – Units are shipped in one piece but may be disassembled into two separate sections for ease of installation.

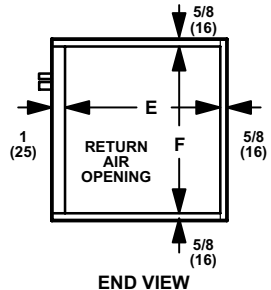
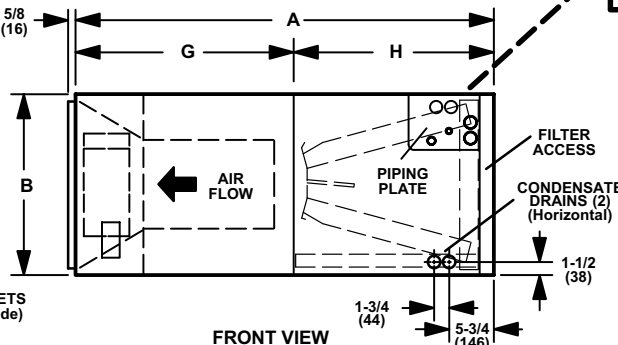
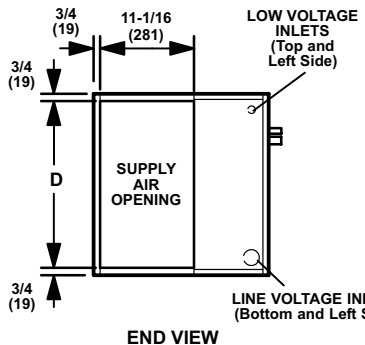
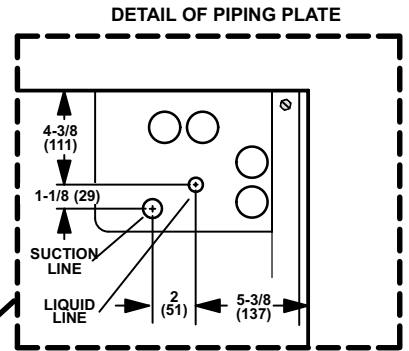
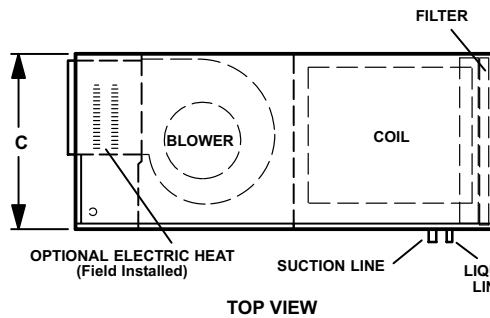

MODEL		A	B	C	D	E	F	G	H
HMG60E1P	in.	62-1/2	21-1/4	24-5/8	19-3/4	23	20	27-7/8	34-5/8
	mm	1588	540	625	502	584	508	708	879

DIMENSIONS - INCHES (MM)

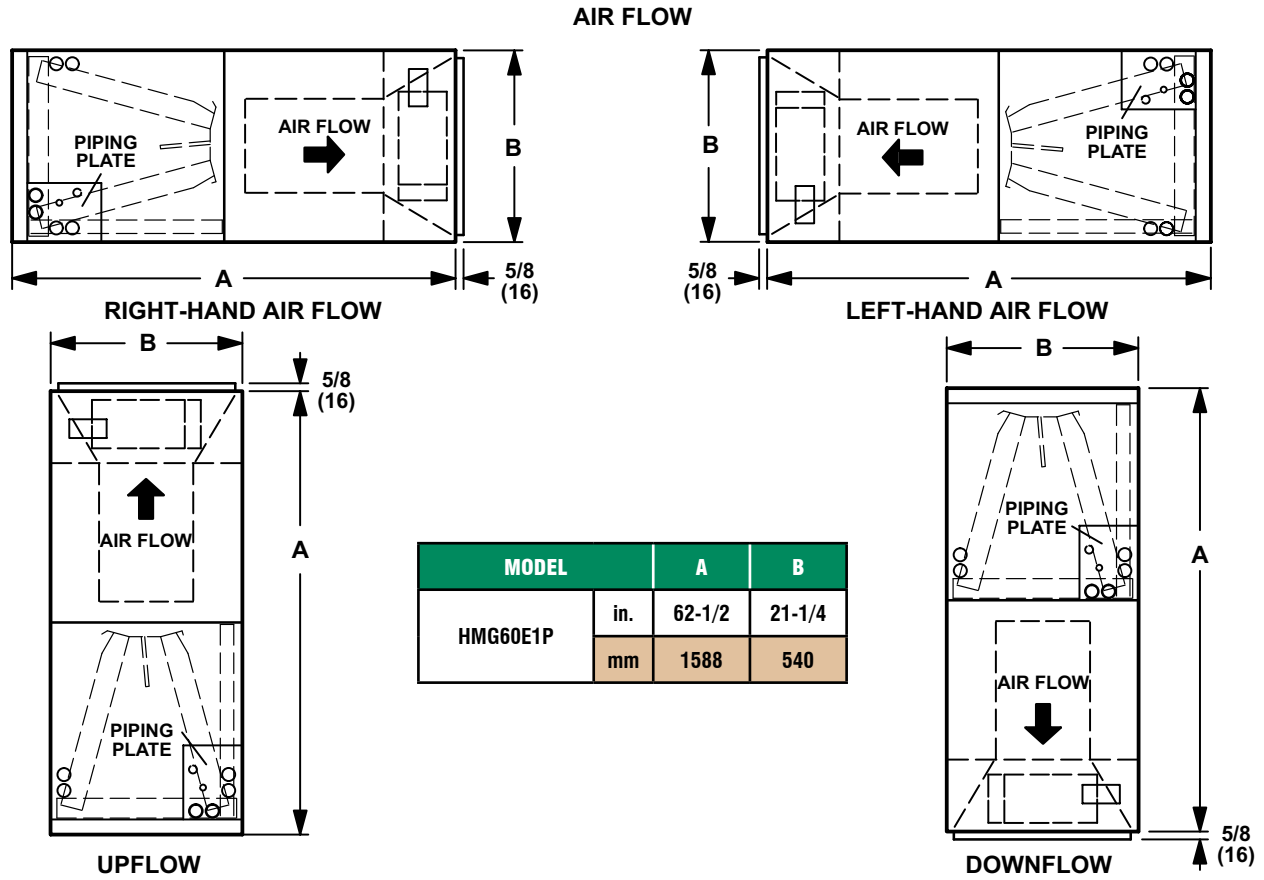

SIDE RETURN UNIT STAND (Upflow Only)

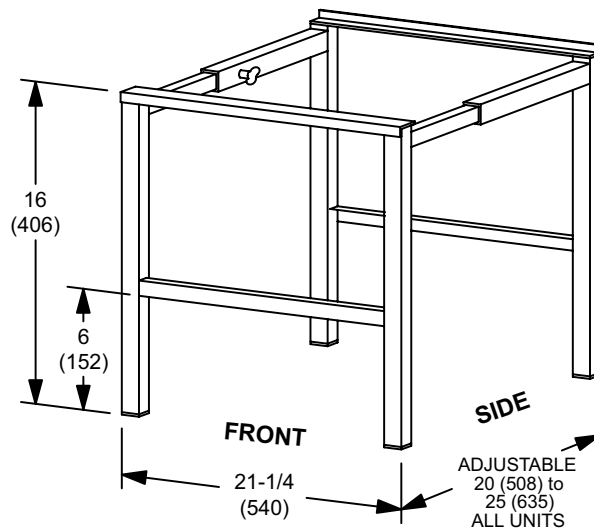

DIMENSIONS - INCHES (MM)

DOWNFLOW COMBUSTIBLE FLOORING BASE

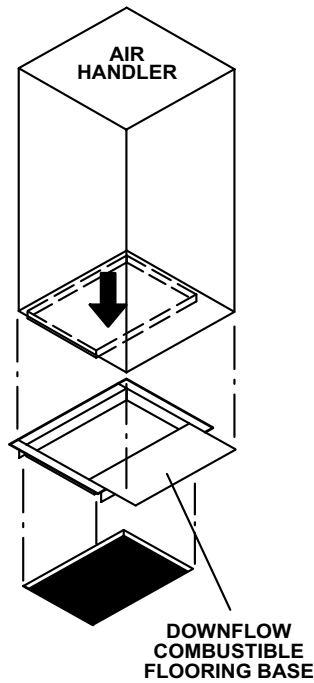

Catalog No. - 44K15

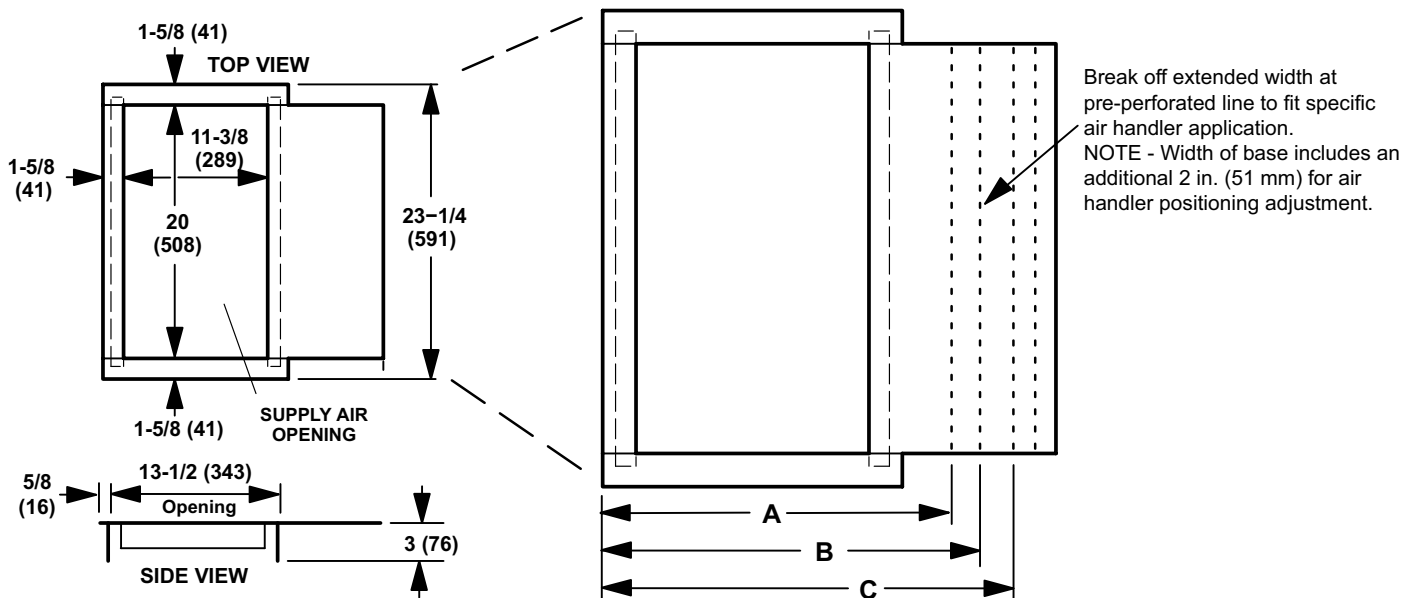

MODEL No.	60	
	in.	mm
A	-	-
B	-	-
C	26-5/8	676

HMG60E1P

SPECIFICATIONS

General Data		Model Number	HMG60E1P
		Nominal Tonnage	5
Connections	Suction (vapor) line (o.d.) - in. sweat		7/8
	Liquid line (o.d.) - in. sweat		3/8
	Condensate - in. fpt		(2) 3/4
Indoor Coil	Net face area - fr. ²		8.33
	Tube outside diameter - in.		3/8
	Number of rows		3
	Fins per inch		14
Blower	Wheel nominal diameter x width - in.		12 x 9
	Blower motor output - hp		1
¹ Filters	Size of filter - in.		20 x 24 x 1
Shipping Data -1 package lbs.			199

ELECTRICAL DATA

Voltage - 1 phase - 60hz	208/230V-1ph
Voltage - 3 phase - 60hz	³ 460V-1PH
² Maximum overcurrent protection (unit only) - All Voltages	15
Minimum circuit ampacity (unit only) - 208/230V	10
Blower motor full load amps - 208/230V	7.6
Minimum circuit ampacity (unit only) - 460V	5
Blower motor full load amps - 460V	4

OPTIONAL ACCESSORIES - ORDER SEPARATELY

Downflow Combustible Flooring Base	44K15
Downflow Conversion Kit	83M57
Electric Heat - See Electric Heat Data tables	5 to 25 kW
Electric Heat Circuit Breaker Cover Kit	82W01
Horizontal Support Frame Kit	56J18
Side Return Unit Stand (Upflow Only)	45K32
Single Point Power Source Control Box	21H39
Wall Hanging Bracket Kit (Upflow Only)	45K30
Remote Outdoor Sensor	X2658

¹ Disposable frame type filter.

² HACR type circuit breaker or fuse.

³ Blower motor is 460V - 1 phase.

Due to ongoing product improvements, specifications and dimensions are subject to change and correction without notice or incurring obligations. Determining the application and suitability for use of any product is the responsibility of the installer. Additionally, the installer is responsible for verifying dimensional data on the actual product prior to beginning any installation preparations.

Third party incentive and rebate programs have precise requirements as to product performance and certification. All products meet applicable regulations in effect on date of manufacture; however, certifications are not necessarily granted for the life of a product. Therefore, it is the responsibility of the applicant to determine whether a specific model qualifies for these incentive/rebate programs.

ACCESSORIES

DESCRIPTION	MODEL
Downflow Combustible Flooring Base	44K15
Downflow Conversion Kit	83M57
Electric Heat - See Electric Heat Data tables	5 to 25 kW
Electric Heat Circuit Breaker Cover Kit	82W01
Horizontal Support Frame Kit	56J18
Side Return Unit Stand (Upflow Only)	45K32
Single Point Power Source Control Box	21H39
Wall Hanging Bracket Kit (Upflow Only)	45K30
Remote Outdoor Sensor	X2658

ELECTRIC HEAT

SIZE	MODEL	C/B SIZE *	WHERE USED	ITEM #
ELECTRIC HEAT KITS - SINGLE PHASE				
5 kW	ECB27-5CB-P	35A	60	17D47
9 kW	ECB27-9CB-P	60A	60	17D52
12 kW	ECB27-12.5CB-P	30A + 45A	60	17D53
15 kW	ECB27-15CB-P	35A + 60A	60	17D54
20 kW	ECB27-20CB-P	60A + 60A	60	17D55
25 kW	ECB27-25CB-P	60A + 45A + 45A	60	17D56

REPLACEMENT CIRCUIT BREAKERS

MODEL		A
Voltage	Description	Item #
208/240V 1 Phase	60A, 2 pole	17K72

"This product complies with all California product labeling laws including, but not limited to, the Safe Drinking Water and Toxic Enforcement Act of 1986, more commonly known as Proposition 65."