

## FEATURES

- Available for cooling and heat pump applications
- Multi-speed ECM blower motor
- Factory-sealed cabinet certified to achieve 2% or less leakage rate at 1.0 inch water column
- Multi-position Installation
- Horizontal and vertical condensate drain pans standard
- Blower and coil slide out for ease of maintenance
- Field Installed heater kits are optional: 5/7.5/10/15/20kW
- AHRI Listed & ETL Certified

## MULTI-POSITION AIR HANDLER

*Constant Torque Motor*  
*Cooling Capacity: 24 - 60 kBTU/h*



## MODEL NUMBER GUIDE

<b>A</b>	<b>M</b>	<b>C</b>	<b>24</b>	<b>S</b>	<b>1</b>	<b>A</b>
Air Handler	Multi-Position	Constant Torque/ Piston	Capacity BTUH x 1000	SE Series	Power 1 = 208/230-1-60	Revision Level

## SPECIFICATIONS

	AMC24S1A	AMC36S1A	AMC60S1A
<b>NOMINAL RATING</b>			
Cooling (BTU/h)	24,000	36,000	60,000
External Static Pressure(in.w.c)	0.8	0.7	0.8
<b>ELECTRICAL DATA</b>			
Voltage / Phase(60Hz)	208/230/1	208/230/1	208/230/1
Min. / Max. Voltage	187/253	187/253	187/253
Min. Circuit Amps	3.3	3.8	5.7
Max. Overcurrent Protection	15	15	15
<b>FAN MOTOR</b>			
Motor Type	ECM	ECM	ECM
Horsepower (HP)	1/3	1/2	3/4
Rated RPM	1050	1050	1050
Full Load Amps (FLA)	2.6	3.0	4.5
<b>FAN BLOWER</b>			
Material	Metal	Metal	Metal
Type	Centrifugal	Centrifugal	Centrifugal
Diameter(in.)	10-5/8	13	13
Height(in.)	8-1/8	10-5/8	10-5/8
<b>EVAPORATOR COIL</b>			
Type	Tube & Fin	Tube & Fin	Tube & Fin
Tube Material	Aluminum	Aluminum	Aluminum
Tube Size(in.)	9/32	9/32	9/32
<b>REFRIGERANT CONNECTION SIZE</b>			
Liquid Line Size (O.D.)	3/8	3/8	3/8
Suction Line Size (O.D.)	3/4	3/4	7/8

## TXV KITS

	Part#	Description	Used On
TXV Kit	TR6-3TONNB	18-36K	MAA18(36,42)S1A, MAA3042S1A, MAA36(42,48,60)S1A, AMP36S1A, AMC24S1A, AMC36S1A, AMP48S1A
	TR6-4TON	42-48K	MAA(18,30)42S1A, MAA36(48,60)S1A, MAA4260S1A, AMP48S1A, AMC36S1A, AMC60S1A
	TR6-5TON	60K	MAA3660S1A, MAA4260S1A, AMP60S1A, AMC60S1A



NOTE: 25" CLEARANCE IS REQUIRED IN THE FRONT OF THE UNIT FOR FILTER AND COIL MAINTENANCE.

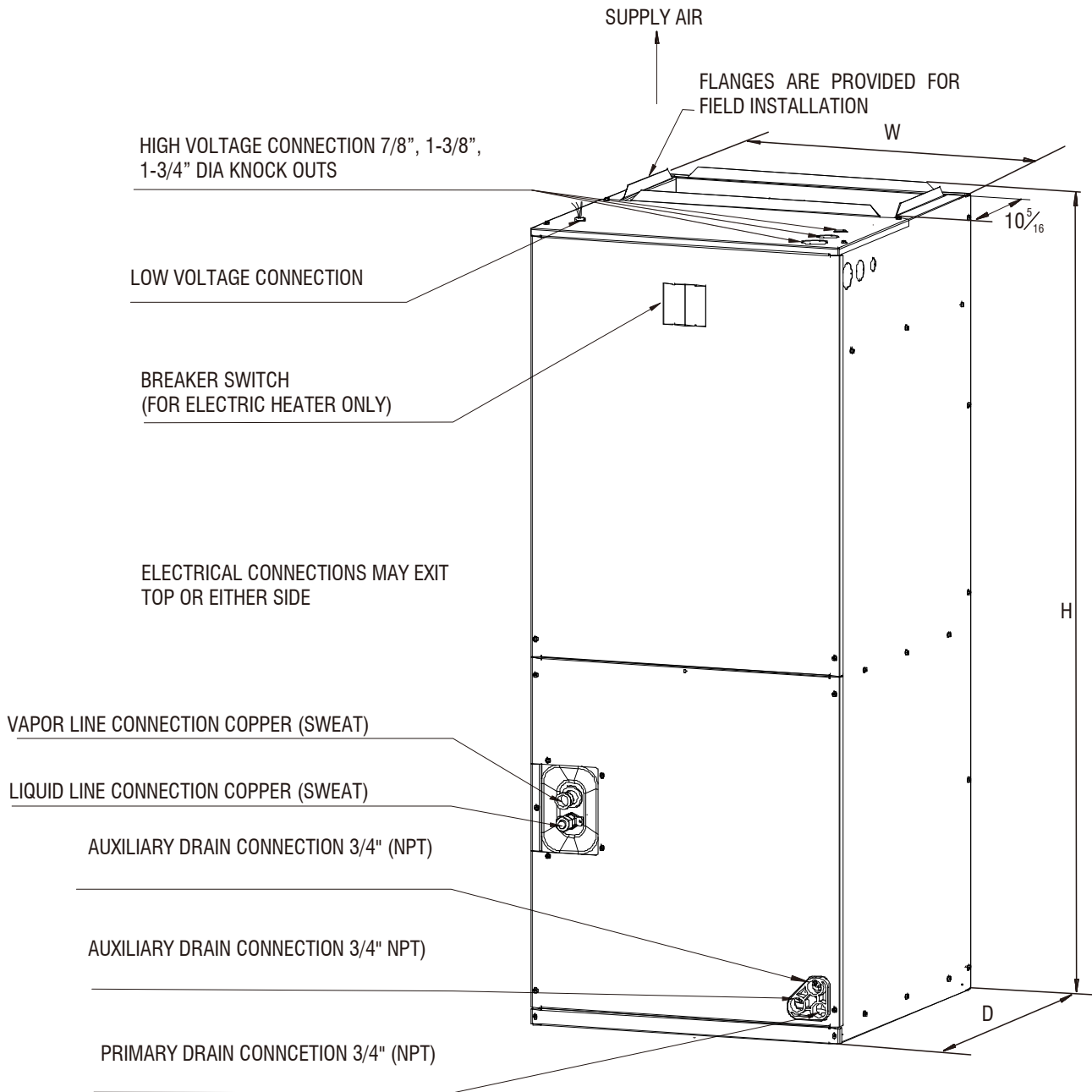

UPFLOW CONFIGURATIONS SHOWN;  
MAY BE INSTALLED UPFLOW, DOWNFLOW,  
HORIZONTAL RIGHT OR LEFT.

	AMC24S1A	AMC36S1A	AMC60S1A
<b>DIMENSIONS AND WEIGHTS</b>			
Height (in.)	41-3/8	46-1/2	54-1/2
Width (in.)	18-1/8	19-5/8	22
Depth (in.)	20-1/2	21-5/8	24
Weight (lbs.)	101	125	159

## AIR FLOW DATA

Air Handler Model	Outdoor Unit Size(Tons)	Motor Speed		CFM Wet Coil without filter and Electric Heat								
				External Static Pressure-Inches W.C.[kPa]								
				0[0]	0.1[.025]	0.2[.050]	0.3[.075]	0.4[0.100]	0.5[0.125]	0.6[0.150]	0.7[0.175]	0.8[0.200]
AMC24S1A	1.5	1	SCFM	590	544	511	447	404	345	311	273	239
			Power/W	49	57	64	70	75	82	91	97	102
			Current/A	0.77	0.81	0.84	0.87	0.91	0.94	0.99	1.02	1.11
		2	SCFM	681	633	591	535	490	446	388	354	313
			Power/W	63	69	77	83	90	96	103	111	118
			Current/A	0.84	0.87	0.93	0.96	0.99	1.03	1.07	1.13	1.16
		3 (Recommended)	SCFM	788	736	687	648	597	558	511	473	429
			Power/W	86	91	100	108	114	121	128	133	142
			Current/A	0.95	0.99	1.11	1.14	1.18	1.21	1.26	1.31	1.37
		4 (Factory Default)	SCFM	883	842	796	758	717	681	642	599	524
			Power/W	121	128	135	144	151	159	165	173	181
			Current/A	1.21	1.28	1.32	1.38	1.43	1.47	1.54	1.59	1.64
		5	SCFM	1103	1073	1036	998	967	934	896	855	814
			Power/W	233	241	249	258	265	275	281	286	291
			Current/A	1.97	2.03	2.09	2.16	2.22	2.29	2.34	2.37	2.41
AMC24S1A	2	1	SCFM	590	544	511	447	404	345	311	273	239
			Power/W	49	57	64	70	75	82	91	97	102
			Current/A	0.77	0.81	0.84	0.87	0.91	0.94	0.99	1.02	1.11
		2	SCFM	681	633	591	535	490	446	388	354	313
			Power/W	63	69	77	83	90	96	103	111	118
			Current/A	0.84	0.87	0.93	0.96	0.99	1.03	1.07	1.13	1.16
		3	SCFM	788	736	687	648	597	558	511	473	429
			Power/W	86	91	100	108	114	121	128	133	142
			Current/A	0.95	0.99	1.11	1.14	1.18	1.21	1.26	1.31	1.37
		4 (Factory Default)	SCFM	883	842	796	758	717	681	642	599	524
			Power/W	121	128	135	144	151	159	165	173	181
			Current/A	1.21	1.28	1.32	1.38	1.43	1.47	1.54	1.59	1.64
		5	SCFM	1103	1073	1036	998	967	934	896	855	814
			Power/W	233	241	249	258	265	275	281	286	291
			Current/A	1.97	2.03	2.09	2.16	2.22	2.29	2.34	2.37	2.41
AMC36S1A	2.5	1	SCFM	898	752	603	511	405	360	301	259	203
			Power/W	78	72	65	60	54	48	41	38	36
			Current/A	0.68	0.64	0.59	0.52	0.46	0.42	0.36	0.29	0.28
		2	SCFM	1026	902	810	694	630	544	490	409	366
			Power/W	109	99	106	111	120	126	135	140	148
			Current/A	0.94	0.86	0.91	0.95	1.03	1.07	1.14	1.18	1.24
		3	SCFM	1161	1114	1052	992	893	825	768	694	646
			Power/W	148	158	164	175	187	193	203	209	219
			Current/A	1.26	1.34	1.39	1.48	1.57	1.61	1.69	1.73	1.81

--- Shaded boxes represent airflow outside the required 300-450 cfm/ton, which are not recommended.

**AIR FLOW DATA CONT.**

Air Handler Model	Outdoor Unit Size(Tons)	Motor Speed		CFM Wet Coil without filter and Electric Heat										
				External Static Pressure-Inches W.C.[kPa]										
				0[0]	0.1[.025]	0.2[.050]	0.3[.075]	0.4[0.100]	0.5[0.125]	0.6[0.150]	0.7[0.175]	0.8[0.200]		
AMC36S1A	2.5	4 (Recommended)	SCFM	1287	1244	1186	1142	1078	969	914	892	893		
			Power/W	194	205	211	221	233	241	252	253	253		
			Current/A	1.62	1.69	1.75	1.83	1.93	1.98	2.07	2.08	2.11		
		5 (Factory Default)	SCFM	1491	1442	1396	1348	1302	1243	1150	1088	1029		
			Power/W	290	298	307	318	325	337	351	362	367		
			Current/A	2.35	2.42	2.49	2.58	2.64	2.73	2.83	2.92	2.96		
AMC36S1A	3	1	SCFM	898	752	603	511	405	360	301	259	203		
			Power/W	78	72	65	60	54	48	41	38	36		
			Current/A	0.68	0.64	0.59	0.52	0.46	0.42	0.36	0.29	0.28		
		2	SCFM	1026	902	810	694	630	544	490	409	366		
			Power/W	109	99	106	111	120	126	135	140	148		
			Current/A	0.94	0.86	0.91	0.95	1.03	1.07	1.14	1.18	1.24		
		3	SCFM	1161	1114	1052	992	893	825	768	694	646		
			Power/W	148	158	164	175	187	193	203	209	219		
			Current/A	1.26	1.34	1.39	1.48	1.57	1.61	1.69	1.73	1.81		
		4	SCFM	1287	1244	1186	1142	1078	969	914	892	893		
			Power/W	194	205	211	221	233	241	252	253	253		
			Current/A	1.62	1.69	1.75	1.83	1.93	1.98	2.07	2.08	2.11		
		5 (Factory Default)	SCFM	1491	1442	1396	1348	1302	1243	1150	1088	1029		
			Power/W	290	298	307	318	325	337	351	362	367		
			Current/A	2.35	2.42	2.49	2.58	2.64	2.73	2.83	2.92	2.96		
		AMC60S1A	3.5	1	SCFM	1344	1284	1226	1151	1076	946	904	893	869
					Power/W	143	151	159	168	177	191	197	195	194
					Current/A	1.23	1.26	1.33	1.41	1.5	1.61	1.63	1.61	1.62
2	SCFM			1531	1477	1418	1366	1299	1239	1138	1064	1001		
	Power/W			200	211	222	231	239	250	266	277	291		
	Current/A			1.73	1.74	1.81	1.89	2.02	2.14	2.22	2.31	2.38		
3 (Recommended)	SCFM			1647	1592	1538	1490	1436	1378	1315	1215	1140		
	Power/W			244	254	263	273	283	300	305	325	336		
	Current/A			2.03	2.11	2.14	2.19	2.31	2.38	2.53	2.64	2.72		
4 (Factory Default)	SCFM			1875	1822	1774	1729	1677	1629	1581	1533	1473		
	Power/W			340	353	365	375	388	399	412	423	437		
	Current/A			2.73	2.79	2.86	3.02	3.12	3.21	3.29	2.38	3.51		
5	SCFM			2021	1967	1924	1879	1828	1785	1742	1694	1641		
	Power/W			409	416	429	447	461	471	487	500	513		
	Current/A			3.21	3.29	3.38	3.52	3.61	3.73	3.76	3.86	4.04		

--- Shaded boxes represent airflow outside the required 300-450 cfm/ton, which are not recommended.

**AIR FLOW DATA CONT.**

Air Handler Model	Outdoor Unit Size(Tons)	Motor Speed		CFM Wet Coil without filter and Electric Heat								
				External Static Pressure-Inches W.C.[kPa]								
				0[0]	0.1[.025]	0.2[.050]	0.3[.075]	0.4[0.100]	0.5[0.125]	0.6[0.150]	0.7[0.175]	0.8[0.200]
AMC60S1A	4	1	SCFM	1344	1284	1226	1151	1076	946	904	893	869
			Power/W	143	151	159	168	177	191	197	195	194
			Current/A	1.23	1.26	1.33	1.41	1.5	1.61	1.63	1.61	1.62
		2	SCFM	1531	1477	1418	1366	1299	1239	1138	1064	1001
			Power/W	200	211	222	231	239	250	266	277	291
			Current/A	1.73	1.74	1.81	1.89	2.02	2.14	2.22	2.31	2.38
		3 (Recommended)	SCFM	1647	1592	1538	1490	1436	1378	1315	1215	1140
			Power/W	244	254	263	273	283	300	305	325	336
			Current/A	2.03	2.11	2.14	2.19	2.31	2.38	2.53	2.64	2.72
		4 (Factory Default)	SCFM	1875	1822	1774	1729	1677	1629	1581	1533	1473
			Power/W	340	353	365	375	388	399	412	423	437
			Current/A	2.73	2.79	2.86	3.02	3.12	3.21	3.29	2.38	3.51
	5	SCFM	2021	1967	1924	1879	1828	1785	1742	1694	1641	
		Power/W	409	416	429	447	461	471	487	500	513	
		Current/A	3.21	3.29	3.38	3.52	3.61	3.73	3.76	3.86	4.04	
AMC60S1A	5	1	SCFM	1344	1284	1226	1151	1076	946	904	893	869
			Power/W	143	151	159	168	177	191	197	195	194
			Current/A	1.23	1.26	1.33	1.41	1.5	1.61	1.63	1.61	1.62
		2	SCFM	1531	1477	1418	1366	1299	1239	1138	1064	1001
			Power/W	200	211	222	231	239	250	266	277	291
			Current/A	1.73	1.74	1.81	1.89	2.02	2.14	2.22	2.31	2.38
		3	SCFM	1647	1592	1538	1490	1436	1378	1315	1215	1140
			Power/W	244	254	263	273	283	300	305	325	336
			Current/A	2.03	2.11	2.14	2.19	2.31	2.38	2.53	2.64	2.72
		4 (Factory Default)	SCFM	1875	1822	1774	1729	1677	1629	1581	1533	1473
			Power/W	340	353	365	375	388	399	412	423	437
			Current/A	2.73	2.79	2.86	3	3.12	3.21	3.29	2.38	3.51
	5	SCFM	2021	1967	1924	1879	1828	1785	1742	1694	1641	
		Power/W	409	416	429	447	461	471	487	500	513	
		Current/A	3.21	3.29	3.38	3.52	3.61	3.73	3.76	3.86	4.04	

--- Shaded boxes represent airflow outside the required 300-450 cfm/ton, which are not recommended.

## HEATER KITS

Model	Air Handler Capacity (kBTU/h)	Electric Heat(kW)	Min. Circuit Ampacity		Max. Fuse or Breaker (HACR) Ampacity		Blower Speed				
			240V	208V	240V	208V	1	2	3	4	5
<b>AMC24S1A</b>											
EHK-05A(UL)	24	5	29	25.5	30	30	•	•	•	•	•
EHK-08A(UL)		7.5	42	36.8	45	40	x	x	•	•	•
EHK-10A(UL)		10	55	48.1	60	50	x	x	•	•	•
<b>AMC36S1A</b>											
EHK-05A(UL)	36	5	29.4	25.9	30	30	•	•	•	•	•
EHK-08A(UL)		7.5	42.4	37.2	45	40	x	•	•	•	•
EHK-10A(UL)		10	55.4	48.5	60	50	x	x	•	•	•
EHK-15B(UL)		15	55.4/26.1	48.5/22.6	60/30	50/25	x	x	•	•	•
EHK-20B(UL)		20	55.4/52.1	48.5/45.2	60/60	60/50	x	x	x	•	•
<b>AMC60S1A</b>											
EHK-05A(UL)	60	5	31.8	28.3	35	30	x	x	•	•	•
EHK-08A(UL)		7.5	44.8	39.6	45	40	x	x	•	•	•
EHK-10A(UL)		10	57.8	50.9	60	60	x	x	•	•	•
EHK-15B(UL)		15	57.8/26.1	50.9/22.6	60/30	60/25	x	x	•	•	•
EHK-20B(UL)		20	57.8/52.1	50.9/45.2	60/60	60/50	x	x	x	•	•

**NOTE:** Heat kit suitable for AHU 4-way position installation.

Ampacities for MCA and Fuse/breaker including the blower motor.

## ELECTRIC HEATER KITS

NO.	Kit	Description	Ref. Air Handler Use
1	EHK-05A(UL)	5kW Heat Strip	24/36/60
2	EHK-08A(UL)	7.5kW Heat Strip	24/36/60
3	EHK-10A(UL)	10kW Heat Strip	24/36/60
4	EHK-15B(UL)	15kW Heat Strip, double Breaker panel	36/60
5	EHK-20B(UL)	20kW Heat Strip, double Breaker panel	36/60



# AMC\*\*S1A



*Due to ongoing product improvements, specifications and dimensions are subject to change and correction without notice or incurring obligations. Determining the application and suitability for use of any product is the responsibility of the installer. Additionally, the installer is responsible for verifying dimensional data on the actual product prior to beginning any installation preparations.*

*Third party incentive and rebate programs have precise requirements as to product performance and certification. All products meet applicable regulations in effect on date of manufacture; however, certifications are not necessarily granted for the life of a product. Therefore, it is the responsibility of the applicant to determine whether a specific model qualifies for these incentive/rebate programs.*

"This product complies with all California product labeling laws including, but not limited to, the Safe Drinking Water and Toxic Enforcement Act of 1986, more commonly known as Proposition 65."