

FEATURES

- High heat-transfer efficiency and low static-pressure drop A-shaped coil
- Foil-faced insulation to prevent energy loss through the cabinet
- Factory-sealed cabinet certified to achieve 2% or less leakage rate at 1.0 inch water column
- Multi-stage blower Speed Control to align with varying capacity demands
- 4-position installation: Upflow, Horizontal Right, Downflow, Horizontal Left
- Horizontal and vertical condensate drain pans standard, primary and secondary condensate fittings
- Field installed electric heater kits: 5, 7.5, 10, 15, 20 kW available as accessories
- Multiple Electrical entry locations
- Dual front panel, blower and coil with slide track
- Integrated filter rack with toolless door access
- Easy-to-braze copper evaporator connection
- Field installed TXV available
- Advanced internal welding process to reduce potential corrosion
- AHRI and ETL listed
- Polymer condensate drain pan with UVC inhibitor to extend product lifetime

SAHP SERIES

MULTI-POSITION AIR HANDLER

PSC Motor

Cooling Capacity: 18 - 60 kBTU/h



Warranty—5 years on parts, 10 years on compressor and heat exchanger
(Some limitations apply; see printed warranty for details.)
www.century-hvac.com



MODEL NUMBER GUIDE

S	AH	P	24	S	1	A
SE Series	Air Handler	PSC Motor	Capacity BTUH x 1000	Standard Efficiency	Power 1 = 208/230-1-60	Revision Level

SPECIFICATIONS

	SAHP18S1A	SAHP24S1A	SAHP36S1A	SAHP48S1A	SAHP60S1A
NOMINAL RATING					
Cooling (BTU/h)	18,000	23,600	34,200	45,000	54,500
CFM (High/Low range)	600	900	1,200	1,400	1,650
External Static Pressure(in.w.c)	0.58 [154]	0.58 [154]	0.58 [154]	0.58 [154]	0.58 [154]
ELECTRICAL DATA					
Voltage / Phase(60Hz)	208/230/1	208/230/1	208/230/1	208/230/1	208/230/1
Min. / Max. Voltage	187/253	187/253	187/253	187/253	187/253
Min. Circuit Amps	1.8	2.5	3.3	4.3	5.0
Max. OvercurrentProtection	15	15	15	15	15
FAN MOTOR					
Motor Type	PSC	PSC	PSC	PSC	PSC
Capacitor (uF)	6	10	15	20	20
Horsepower (HP)	1/5	1/5	1/3	1/2	1/2
Rated RPM	755	820	980	900	980
Full Load Amps (FLA)	1.4	2.0	2.6	3.4	4.0
FAN BLOWER					
Material	Metal	Metal	Metal	Metal	Metal
Type	Centrifugal	Centrifugal	Centrifugal	Centrifugal	Centrifugal
Diameter(in.)	10	10	10	10	10
Height(in.)	8	10	10	10	10
Coil drain Connection FPT (in.)	3/4	3/4	3/4	3/4	3/4
EVAPORATOR COIL					
Type	Aluminum-Hydrophilic Aluminum	Aluminum-Hydrophilic Aluminum	Aluminum-Hydrophilic Aluminum	Aluminum-Hydrophilic Aluminum	Aluminum-Hydrophilic Aluminum
Tube Material	Aluminum	Aluminum	Aluminum	Aluminum	Aluminum
Tube Size(in.)	9/32	9/32	9/32	9/32	9/32
SOUND POWER					
Sound Power	65	67	70	71	73
REFRIGERANT CONNECTION SIZE					
Liquid Line Size (O.D.)	3/8	3/8	3/8	3/8	3/8
Suction Line Size (O.D.)	3/4	3/4	3/4	7/8	7/8
SERVICE VALVE					
Liquid (in.)	3/8	3/8	3/8	3/8	3/8
Suction (in.)	3/4	3/4	3/4	7/8	7/8

Factory installed piston size for each model. Additional piston sizes are provided in the ship with literature bag as necessary.

MODEL	47	52	56	58	60	64	68	70	73	75	80	83
18	x*											
24		x*										
30			x			x*						
36			x			x*						
42								x	x*			
48								x	x*			
60											x*	

*Means that this piston is pre-installed

	SAHP18S1A	SAHP24S1A	SAHP36S1A	SAHP48S1A	SAHP60S1A
DIMENSIONS AND WEIGHTS					
Height (in.)	41 - 3/8	46 - 1/2	46 - 1/2	51 - 1/2	51 - 1/2
Width (in.)	18 - 1/8	19 - 5/8	19 - 5/8	22	22
Depth (in.)	20 - 1/2	21 - 5/8	21 - 5/8	24	24
Supply Duct (in.)	16	18	18	19 - 1/2	19 - 1/2
Weight (lbs.)	108	130	130	157	165

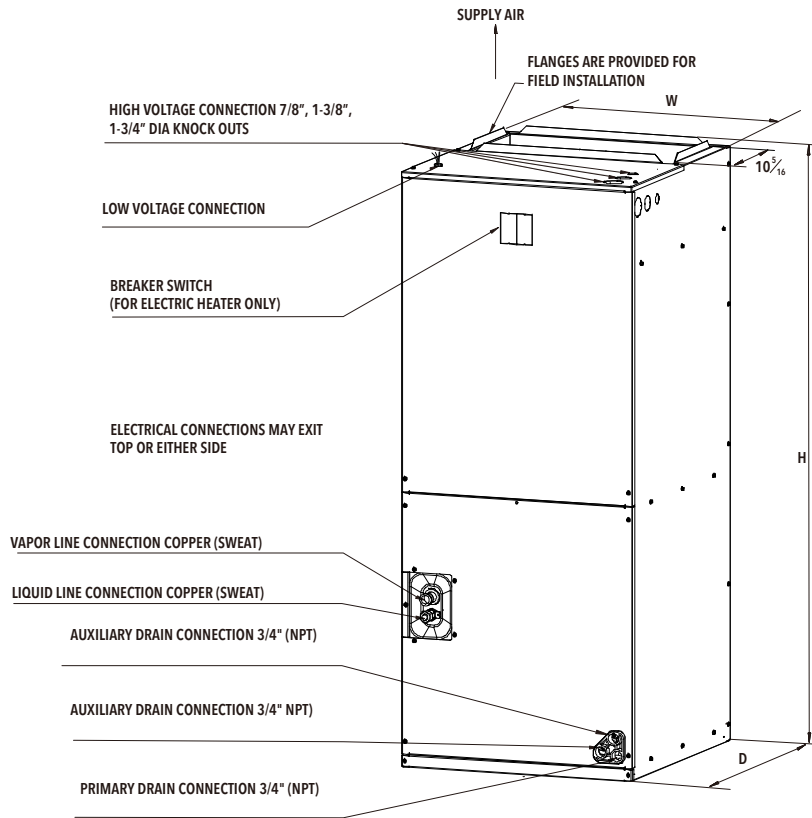

NOTE: 25" CLEARANCE IS REQUIRED IN THE FRONT OF THE UNIT FOR FILTER AND COIL MAINTENANCE

UPFLOW CONFIGURATION SHOWN;
MAY BE INSTALLED UPFLOW, DOWNFLOW,
HORIZONTAL RIGHT OR LEFT

ELECTRIC HEATER KITS

Model	Air Handler Capacity (kBtu/h)	Electric Heat (kW)	Min. Circuit Ampacity		Max. Fuse or Breaker (HACR) Ampacity		Blower Speed		
			240V	208V	240V	208V	1	2	3
SAHP18S1A									
EHK-05	18	5	26.1	22.6	30	25	•	•	•
EHK-08		7.5	39.1	33.9	40	35	•	•	•
EHK-10		10	52.1	45.2	60	50	•	•	•
SAHP24S1A									
EHK-05	24	5	26.1	22.6	30	25	•	•	•
EHK-08		7.5	39.1	33.9	40	35	•	•	•
EHK-10		10	52.1	45.2	60	50	•	•	•
SAHP36S1A									
EHK-05	36	5	26.1	22.6	30	25	•	•	•
EHK-08		7.5	39.1	33.9	40	35	•	•	•
EHK-10		10	52.1	45.2	60	50	•	•	•
EHK-15		15	52.1/26.1	45.2/22.6	60/30	50/25	•	•	•
EHK-20		20	52.1/52.1	45.2/45.2	60/60	60/50	•	•	•
SAHP48S1A									
EHK-05	48	5	26.1	22.6	30	25	-	-	•
EHK-08		7.5	39.1	33.9	40	35	-	-	•
EHK-10		10	52.1	45.2	60	50	-	-	•
EHK-15		15	52.1/26.1	45.2/22.6	60/30	50/25	-	-	•
EHK-20		20	52.1/52.1	45.2/45.2	60/60	50/50	-	-	•
SAHP60S1A									
EHK-05	60	5	26.1	22.6	35	25	•	•	•
EHK-08		7.5	39.1	33.9	45	35	•	•	•
EHK-10		10	52.1	45.2	60	50	•	•	•
EHK-15		15	52.1/26.1	45.2/22.6	60/30	60/25	•	•	•
EHK-20		20	52.1/52.1	45.2/45.2	60/60	60/50	•	•	•



Kit	Description	Ref. Air Handler Use
EHK-05	5kW Heat Strip	24/36/48/60
EHK-08	7.5kW Heat Strip	24/36/48/60
EHK-10	10kW Heat Strip	24/36/48/60
EHK-15	15kW Heat Strip, double Breaker panel	36/48/60
EHK-20	20kW Heat Strip, double Breaker panel	36/48/60

AIR FLOW DATA

Air Handler Model	Outdoor Unit Size(Tons)	Motor Speed		CFM Wet Coil without filter and Electric Heat								
				External Static Pressure-Inches W.C.[kPa]								
				0[0]	0.1[0.025]	0.2[0.050]	0.3[0.075]	0.4[0.100]	0.5[0.125]	0.6[0.150]	0.7[0.175]	0.8[0.200]
SAHP18S1A	1.5	Low	CFM	649	618	586	548	509	467	420	350	283
			Watts	207	203	198	191	187	182	173	162	151
			Current/A	0.90	0.89	0.87	0.85	0.83	0.81	0.79	0.75	0.7
		Medium	CFM	815	796	758	720	677	624	573	522	421
			Watts	243	236	230	224	218	210	204	198	184
			Current/A	1.04	1.01	0.99	0.97	0.94	0.92	0.89	0.87	0.82
		High	CFM	945	933	897	855	811	757	692	633	566
			Watts	313	305	297	289	280	270	259	250	242
			Current/A	1.34	1.31	1.28	1.25	1.22	1.19	1.15	1.12	1.09
SAHP24S1A	2	Low	CFM	1081	1028	977	909	796	714	628	539	407
			Watts	289	281	274	265	253	244	234	223	206
			Current/A	1.28	1.25	1.23	1.20	1.17	1.14	1.11	1.08	1.0
		Medium	CFM	1231	1176	1122	1068	976	851	757	659	552
			Watts	315	309	303	297	287	274	263	252	242
			Current/A	1.37	1.35	1.33	1.32	1.28	1.24	1.21	1.17	1.14
		High	CFM	1434	1371	1311	1249	1185	1081	922	807	689
			Watts	423	409	399	389	380	364	344	329	314
			Current/A	1.88	1.84	1.8	1.77	1.74	1.7	1.64	1.59	1.55
SAHP36S1A	3	Low	CFM	1091	1048	1001	947	851	764	677	571	/
			Watts	323	319	314	307	294	281	268	251	/
			Current/A	1.53	1.53	1.52	1.50	1.48	1.45	1.43	1.40	/
		Medium	CFM	1335	1286	1230	1172	1103	986	866	752	/
			Watts	368	361	354	348	339	325	312	297	/
			Current/A	1.72	1.71	1.7	1.68	1.67	1.64	1.62	1.59	/
		High	CFM	1526	1467	1403	1335	1259	1181	1030	913	/
			Watts	473	462	452	442	430	419	399	383	/
			Current/A	2.27	2.26	2.24	2.22	2.21	2.18	2.15	2.21	/
SAHP48S1A	4	Low	CFM	1496	1441	1383	1326	1273	1214	1137	872	746
			Watts	491	472	456	442	430	417	399	351	328
			Current/A	2.30	2.25	2.21	2.18	2.14	2.10	2.05	1.92	1.85
		Medium	CFM	1798	1731	1660	1597	1529	1452	1376	1283	921
			Watts	562	548	535	523	509	497	582	465	410
			Current/A	2.56	2.52	2.48	2.44	2.40	2.37	2.33	2.28	2.12
		High	CFM	1970	1896	1819	1737	1662	1580	1501	1411	1291
			Watts	704	689	673	656	640	624	610	593	570
			Current/A	3.30	3.25	3.20	3.15	3.10	3.05	3.00	2.95	2.88
SAHP60S1A	5	Low	CFM	1872	1802	1747	1687	1628	1567	1500	1416	1140
			Watts	716	682	662	647	627	610	590	565	495
			Current/A	3.09	2.95	2.87	2.81	2.73	2.66	2.58	2.48	2.2
		Medium	CFM	2080	2012	1948	1886	1821	1753	1684	1604	1505
			Watts	751	729	711	694	675	657	638	617	592
			Current/A	1.15	1.08	1.01	0.95	0.88	0.82	0.94	0.85	0.97
		High	CFM	2198	2120	2068	1979	1908	1836	1760	1677	1584
			Watts	858	833	817	792	771	751	731	710	687
			Current/A	3.70	3.60	3.53	3.42	3.34	3.26	3.17	3.08	2.99

NOTE: --- Shaded boxes represent airflow outside the required 300-450 cfm/ton, which are not recommended.

"This product complies with all California product labeling laws including, but not limited to, the Safe Drinking Water and Toxic Enforcement Act of 1986, more commonly known as Proposition 65."

Due to ongoing product improvements, specifications and dimensions are subject to change and correction without notice