

SPECIFICATIONS

Approvals

- Tested with matching air conditioners and heat pump units in accordance with AHRI Standard 210/240-2023
- AHRI Certified system match-ups and expanded ratings
- ETL Listed to US and Canadian safety standards and components within are bonded for grounding to meet safety standards for servicing required by NEC and CEC
- Optional electric heaters are ETL listed and rated in accordance with US Department of Energy (DOE) test procedures and Federal Trade Commission (FTC) labeling regulations
- Blower performance data according to unit tests conducted in air test chamber
- Approved for installation in manufactured housing and mobile homes
- ISO 9001 Registered Manufacturing Quality System

Application

- 1.5 to 3 ton nominal sizes
- Upflow or horizontal applications
NOTE: Downflow applications require optional conversion kit
- Applicable to expansion valve systems in cooling applications and check and expansion valve systems in heat pump applications
- Wide-range R-454B check and expansion valve is factory installed
- Optional field installed electric heaters available in several sizes for additive heating capacity

Refrigerant System

- 1 Aluminum Tube and Fin Coil
 - Enhanced aluminum alloy tube/enhanced fin coil for superior corrosion resistance
 - Aluminum tubing, hairpins, distributor and header tubes.
 - Ripple-edged aluminum fins
 - Twin coil construction assembled in a "A" configuration for large surface area
 - Provides excellent heat transfer and low air resistance for maximum efficiency
 - Precise circuiting for uniform refrigerant distribution
 - Lanced fins provide maximum exposure of fin surface to air stream
 - Axial grooved tubing provides superior heat transfer
 - Coil thoroughly factory tested under high pressure to ensure leakproof construction

Refrigerant System (Continued)

- 2 Mechanical or Brazed Line Set Connections
 - Copper refrigerant sweat connections on both liquid and suction lines for easy brazing
 - Lines extend outside of the cabinet for ease of connection
 - See dimension drawings for locations

Braze-Free/Press Fitting Flexibility

- Units can accommodate braze-free or press fittings for installation versatility

- 3 R-454B Check and Expansion Valve

- For use with R-454B systems
- Wide range valve with Chatleff style fitting
- Factory installed on all models, internal to cabinet

HMA-P SERIES

ENHANCED AIR HANDLER

**Multi-position
TXV Furnished
PSC Motor
1.5 - 3.5 Tons**



Warranty—6 years on parts
(Some limitations apply; see printed warranty for details.)
www.century-hvac.com



Refrigerant Detection System (RDS)

- Complies with UL 60335-2-40 approved standard
- Required for all systems using R-454B refrigerant
- Consists of a factory installed Refrigerant Detection System (RDS) sensor and a Refrigerant Detection System (RDS) Blower Control Board

Refrigerant Detection System (RDS) Air Handler Sensor

- Sensor ensures safe operation for systems equipped with R-454B refrigerant
 - Indoor sensor will detect any R-454B refrigerant
- NOTE:** Sensor must be repositioned for horizontal-right, horizontal-left, and downflow applications.

Blower Control Board

- Connected to the RDS sensor
 - Used as interface between indoor unit and thermostat to control system
 - Ensures safe operation for systems equipped with R-454B refrigerant
 - If R-454B refrigerant is detected, the refrigerant detection system will stop compressor and/or heating operation and operate the blower to reduce concentrations in the conditioned space
 - Once safe levels are reached the HVAC system will resume normal operation
 - Multi-color LED for system status and as an aid in troubleshooting
 - Flashing LED codes for system status (Green/Blue) and diagnosing Sensor errors (Red)
 - Alarm relay can trigger an external alarm if a leak is detected
 - Zone relay opens all zone dampers (if part of a zoning system) if R-454B refrigerant is detected
 - Power is disabled to thermostat to prevent demand if R-454B refrigerant is detected
 - On system start-up blower will run for five minutes and any thermostat demands are disabled
- NOTE:** Refer to the Installation Instructions for additional information

4 Blower

Permanent Split Capacitor (PSC) Motor

- Multi-speed PSC motor
- Choice of blower speeds is available
- Speed changes easily accomplished by a simple wiring change
- Blower is easily removed from unit for servicing

Time Delay Blower Relay

- Relay allows one second blower "on" delay before continuous fan or cooling operation and 45 second blower "off" delay after continuous fan or cooling operation

5 Cabinet

- Constructed of heavy gauge galvanized steel
- Pre-painted cabinet finish
- Completely insulated with foil faced fiberglass insulation
- Removable panels provide complete service access
- Filter access door for easy filter replacement
- Thumbscrews hold filter door in place
- Electrical inlets provided in sides and top of cabinet
- See dimension drawing for locations
- Plugs in cabinet for drain connections for upflow (left and right) and horizontal applications
- See dimension drawing

Low Leakage Cabinet

- All models have less than 2% air leakage and meet ANSI/ASHRAE Standard 193-2010 "Method of Test for Determining the Air Tightness of HVAC Equipment"

Upflow/Horizontal Capability (Optional Downflow)

- Shipped for upflow and horizontal right-hand discharge
- May be field converted to horizontal left-hand air discharge by repositioning horizontal drain pan
- Optional downflow kit required for field conversion

Side Return Unit Stand (Upflow Only)

- Raises unit 16 in. above floor for side return air duct connection
- Eliminates need for wooden platform construction
- All aluminum construction
- Two adjustable frames fit all sizes

Wall Hanging Bracket Kit (Upflow Only)

- Allows unit to be hung on wall at any height
- Consists of heavy-gauge steel support brackets (one for air handler, one for wall mount)
- Screws furnished for fastening one bracket to unit
- Bolts for fastening one bracket to wall are field provided

Optional Accessories

Downflow Conversion Kit

- Required for field conversion to downflow position
- Kit consists of insulated downflow drain pan, insulated drain pan drip shields, coil drip shields, seal plates and support brackets for repositioning coil and drain pan

Horizontal Support Frame Kit

- Provides support of unit in horizontal applications
- Consists of (2) 1 x 1-1/2 x 32-5/8 in. and (2) 1 x 3 x 53-7/8 in. painted heavy gauge cold rolled steel support channels with assembly and suspending holes
- Bolts and nuts furnished for field assembly
- Suspending rods must be field provided

High Performance Economizer (Commercial Applications Only)

- Designed for applications requiring outdoor air to be utilized in a commercial HVAC system
- Allows the entry of fresh outdoor air for free cooling, reducing the requirement for mechanical cooling
- Heavy gauge galvanized steel cabinet lined with thick fiberglass insulation
- Mixed air sensor, outdoor air sensor and 24VAC transformer furnished
- Approved for California Title 24 building standards
- ASHRAE 90.1-2010 compliant

6 Anti-Microbial Dual Position Drain Pans

- Anti-Microbial additive resists growth of mold and mildew on drain pan which improves indoor air quality and reduces drain line blockage
- Drain pans designed for upflow or horizontal applications
- Deep, corrosion resistant high temperature engineered polymer drain pans have dual pipe drains
- See dimension drawing

7 Filter

- Disposable 1 inch filter is furnished
- Filter rack furnished in cabinet for easy filter installation
- See Specifications tables for filter sizes

8 Transformer

- 24 volt transformer furnished as standard
- Factory installed in the unit control box

9 Optional Electric Heat

- ETL listed
- Field install internal to unit cabinet
- Helix wound nichrome heating elements exposed directly in air stream

resulting in instant heat transfer, low element temperatures and long service life

- Each element equipped with accurately located limit control with fixed temperature off setting and automatic reset
- Thermal sequencer relay brings elements on and off line, in sequence and equal increments, with time delay between each
- Heating control relay(s) furnished as standard
- Factory assembled with controls installed and wired
- Electric heat control wiring plugs into mating connector on air handler unit
- All heaters are equipped with circuit breakers for overload and short circuit protection
- Factory wired and mounted on electric heat unit
- Current sensitive and temperature actuated
- Manual reset
- Flexible plastic circuit breaker cover protects circuit breaker in areas with high humidity or unconditioned areas to prevent nuisance tripping
- Circuit breakers qualify as disconnect means at unit in many areas, eliminate the need for field provided disconnect
- Consult local electrical code in your area

Optional Accessories

Single-Point Power Source Control Box

- Control Box may be used with optional electric heat when single power supply is connected to multi-circuit electric heat
- Field installs external to the unit cabinet on either side or top
- Constructed of heavy gauge steel, baked enamel finish, pre-punched mounting holes, electrical inlet knockouts, and terminal strip
- Removeable cover provides easy access
- Dimensions (H x W x D) - 7 x 7 x 4 in.

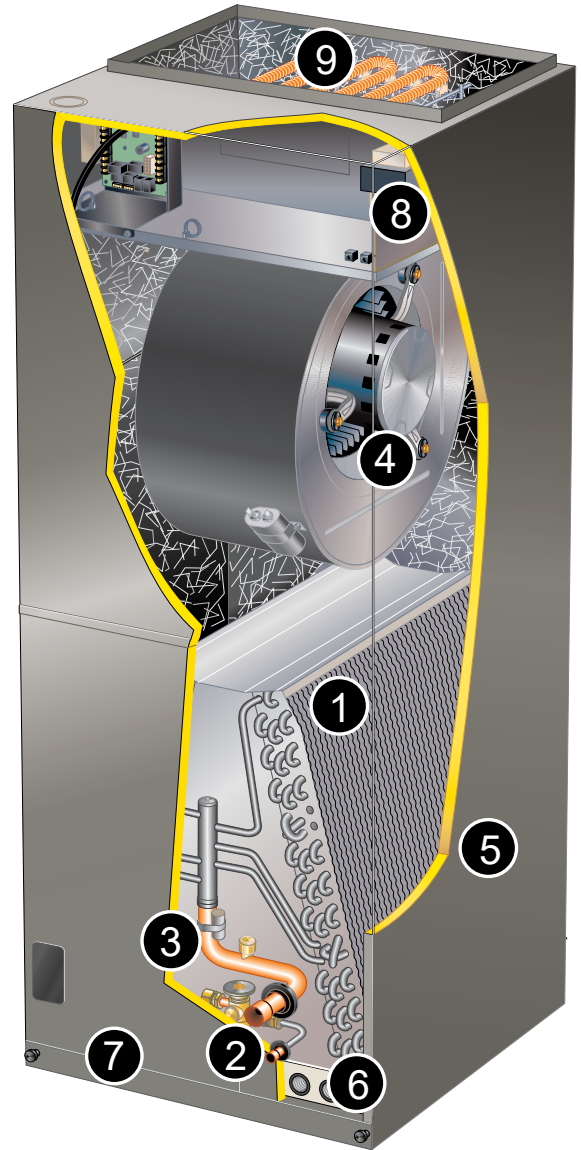

 **Century**®

MODEL NUMBER GUIDE

H	M	A	18	P	X	1	S
Air Handler	Multi-Position	R-454B	Capacity BTUH x 1000	PSC Motor	TXV Included	Power 1 = 208/230-1-60	Series

PHYSICAL

Model		HMA18PX1S	HMA24PX1S	HMA30PX1S	HMA36PX1S	HMA42PX1S
Nominal Tonnage		1.5	2	2.5	3	3.5
Refrigerant Type		R-454B	R-454B	R-454B	R-454B	R-454B
Connections	Liquid line (OD) sweat - in.	3/8	3/8	3/8	3/8	3/8
	Suction line (OD) sweat - in.	3/4	3/4	3/4	7/8	7/8
	Condensate drain (FPT) - in.	(2) 3/4	(2) 3/4	(2) 3/4	(2) 3/4	(2) 3/4
Indoor Coil	Net face area - ft. ²	3.30	3.77	4.72	5.66	5.66
	Tube diameter - in.	3/8	3/8	3/8	3/8	3/8
	Rows	3	3	3	3	3
	Fins - in.	15	15	15	15	15
Blower	HP	1/5	1/3	1/2	1/3	1/2
	Wheel nominal diameter x width - in.	9 x 6	9 x 6	10 x 8	10 x 8	10 x 8
	Air volume range - in.	420 - 920	590 - 1105	770 - 1310	805 - 1560	1155 - 1815
Filters ¹		15 x 20 x 1	15 x 20 x 1	15 x 20 x 1	18 x 20 x 1	18 x 20 x 1
Shipping Data - lbs.		129	136	143	169	169

ELECTRICAL

Model	HMA18PX1S	HMA24PX1S	HMA30PX1S	HMA36PX1S	HMA42PX1S
Line voltage date (Volts-Phase-Hz)	208/230-1-60	208/230-1-60	208/230-1-60	208/230-1-60	208/230-1-60
Maximum overcurrent protection (MOCP) amps (unit) ²	15	15	15	15	15
Minimum circuit ampacity (MCA) (unit) ³	5.0	5.0	5.0	5.0	5.0
Blower Motor Full Load Amps	1.1	1.6	2.2	2.0	2.5

ACCESSORIES

DESCRIPTION	WHERE USED	KIT NUMBER
Down-flow Conversion Kit	18, 24, 30	Y9658
	36, 42	Y9659
Horizontal Support Frame kit	All Models	56J18
Side Return Unit Stand (upflow only)	All Models	45K32
Single Point Power Source Control Box (For Electric Heat)	All Models	21H39
Wall Hanging Bracket Kit (upflow only)	All Models	45K30
High Performance Economizer (Commercial Only)	All Models	10U53

HMA18PX1S PERFORMANCE

External Static Pressure in w.g.	Air Volume / Watts at Various Blower Speeds					
	High		Medium		Low	
	CFM	Watts	CFM	Watts	CFM	Watts
0.10	920	264	690	190	540	144
0.20	880	251	670	183	525	140
0.30	855	238	640	176	505	136
0.40	790	224	605	167	470	130
0.50	710	210	550	155	420	122

HMA24PX1S PERFORMANCE

External Static Pressure in w.g.	Air Volume / Watts at Various Blower Speeds					
	High		Medium		Low	
	CFM	Watts	CFM	Watts	CFM	Watts
0.10	1105	342	1010	280	675	210
0.20	1045	322	980	262	675	202
0.30	1000	307	940	247	655	192
0.40	915	284	805	235	630	180
0.50	855	268	740	216	590	170

HMA30PX1S PERFORMANCE

External Static Pressure in w.g.	Air Volume / Watts at Various Blower Speeds					
	High		Medium		Low	
	CFM	Watts	CFM	Watts	CFM	Watts
0.10	1310	496	1080	391	870	310
0.20	1260	466	1055	378	870	301
0.30	1215	449	1025	361	855	288
0.40	1155	431	985	343	810	278
0.50	1085	408	935	325	770	265

HMA36PX1S PERFORMANCE

External Static Pressure in w.g.	Air Volume / Watts at Various Blower Speeds					
	High		Medium		Low	
	CFM	Watts	CFM	Watts	CFM	Watts
0.10	1560	532	1275	402	1020	295
0.20	1520	518	1240	388	970	287
0.30	1445	502	1190	375	955	280
0.40	1395	480	1150	363	910	270
0.50	1325	460	1085	346	805	254

HMA42PX1S PERFORMANCE

External Static Pressure in w.g.	Air Volume / Watts at Various Blower Speeds					
	High		Medium		Low	
	CFM	Watts	CFM	Watts	CFM	Watts
0.10	1815	674	1524	498	1300	394
0.20	1755	652	1495	486	1275	387
0.30	1695	634	1450	473	1250	376
0.40	1605	607	1390	455	1210	367
0.50	1530	582	1345	441	1155	356

NOTE - All air data measured external to unit with dry coil and 1 inch non-pleated air filter in place.
Electric heaters have no appreciable air resistance.

ELECTRIC HEAT DATA - HMA18PX1S

Electric Heat Model Number	Input			Blower Motor Full Load Amps	Minimum Circuit Ampacity ²	Maximum Circuit Ampacity ³
	Volt	kW	Btuh ¹			
5 kW ECB45-5 (27A09) Terminal Block ECB45-5CB(27A13) 30A Circuit Breaker	208	3.6	12,300	1.1	23	25⁴
	220	4.0	13,800	1.1	24	25⁴
	230	4.4	15,000	1.1	25	25⁴
	240	4.8	16,400	1.1	26	30
7.5 kW ECB45-7.5 (27A10) Terminal Block ECB45-7.5CB(27A14) 45A Circuit Breaker	208	5.6	19,200	1.1	35	35
	220	6.3	21,500	1.1	37	40⁴
	230	6.9	23,500	1.1	39	40⁴
	240	7.5	25,600	1.1	40	40⁴
10 kW ECB45-10 (27A11) Terminal Block ECB45-10CB(27A15) 60A Circuit Breaker	208	7.2	24,600	1.1	45	45⁴
	220	8.0	27,500	1.1	47	50⁴
	230	8.8	30,000	1.1	49	50⁴
	240	9.6	32,700	1.1	51	60

Note - Circuit 1 Minimum Circuit Ampacity includes the Blower Motor Full Load Amps.

1. Electric heater capacity only - does not include additional blower motor heat capacity.
2. Refer to National or Canadian Electrical Code manual to determine wire, fuse and disconnect size requirements. Use wires suitable for at least 167°F.
3. HACR type breaker or fuse.
4. **Bold indicates that the circuit breaker must be replaced with size shown.**

ELECTRIC HEAT DATA - HMA24PX1S

Electric Heat Model Number	Input			Blower Motor Full Load Amps	Minimum Circuit Ampacity ²	Maximum Circuit Ampacity ³
	Volt	kW	Btuh ¹			
5 kW ECB45-5 (27A09) Terminal Block ECB45-5CB(27A13) 30A Circuit Breaker	208	3.6	12,300	1.6	24	25⁴
	220	4.0	13,800	1.6	25	25⁴
	230	4.4	15,000	1.6	26	30
	240	4.8	16,400	1.6	27	30
7.5 kW ECB45-7.5 (27A10) Terminal Block ECB45-7.5CB(27A14) 45A Circuit Breaker	208	5.6	19,200	1.6	36	40⁴
	220	6.3	21,500	1.6	38	40⁴
	230	6.9	23,500	1.6	39	40⁴
	240	7.5	25,600	1.6	41	45
10 kW ECB45-10 (27A11) Terminal Block ECB45-10CB(27A15) 60A Circuit Breaker	208	7.2	24,600	1.6	45	45⁴
	220	8.0	27,500	1.6	48	50⁴
	230	8.8	30,000	1.6	50	50⁴
	240	9.6	32,700	1.6	52	60

Note - Circuit 1 Minimum Circuit Ampacity includes the Blower Motor Full Load Amps.

1. Electric heater capacity only - does not include additional blower motor heat capacity.
2. Refer to National or Canadian Electrical Code manual to determine wire, fuse and disconnect size requirements. Use wires suitable for at least 167°F.
3. HACR type breaker or fuse.
4. **Bold indicates that the circuit breaker must be replaced with size shown.**

ELECTRIC HEAT DATA - HMA30PX1S

Electric Heat Model Number	Input			Blower Motor Full Load Amps	Minimum Circuit Ampacity ²		Maximum Circuit Ampacity ³		Single Point Power Source	
	Volt	kW	Btuh ¹		Ckt 1	Ckt 2	Ckt 1	Ckt 2	Minimum Circuit Ampacity ²	Maximum Circuit Ampacity ³
5 kW ECB45-5 (27A09) Terminal Block ECB45-5CB(27A13) 30A Circuit Breaker	208	3.6	12,300	2.2	24	N/A	25⁴	N/A	N/A	N/A
	220	4.0	13,800	2.2	26	N/A	30	N/A	N/A	N/A
	230	4.4	15,000	2.2	27	N/A	30	N/A	N/A	N/A
	240	4.8	16,400	2.2	28	N/A	30	N/A	N/A	N/A
7.5 kW ECB45-7.5 (27A10) Terminal Block ECB45-7.5CB(27A14) 45A Circuit Breaker	208	5.6	19,200	2.2	37	N/A	40⁴	N/A	N/A	N/A
	220	6.3	21,500	2.2	39	N/A	40⁴	N/A	N/A	N/A
	230	6.9	23,500	2.2	40	N/A	40⁴	N/A	N/A	N/A
	240	7.5	25,600	2.2	42	N/A	45	N/A	N/A	N/A
10 kW ECB45-10 (27A11) Terminal Block ECB45-10CB(27A15) 60A Circuit Breaker	208	7.2	24,600	2.2	46	N/A	50⁴	N/A	N/A	N/A
	220	8.0	27,500	2.2	49	N/A	50⁴	N/A	N/A	N/A
	230	8.8	30,000	2.2	51	N/A	60	N/A	N/A	N/A
	240	9.6	32,700	2.2	53	N/A	60	N/A	N/A	N/A
12.5 kW ECB45-12.5CB (27A16) (1) 50A and (1) 25A Circuit Breaker	208	9.4	32,000	2.2	40	19	40⁴	20 ⁴	59	60
	220	10.5	35,800	2.2	43	20	45⁴	20 ⁴	62	70
	230	11.5	39,200	2.2	44	21	45⁴	25	65	70
	240	12.5	42,600	2.2	46	22	50	25	68	70
15 kW ECB45-15CB (27A17) (1) 60A and (1) 25A Circuit Breaker	208	10.8	36,900	2.2	46	22	50⁴	25	68	70
	220	12.1	41,300	2.2	49	23	50⁴	25	72	80
	230	13.2	45,100	2.2	51	24	60	25	75	80
	240	14.4	49,100	2.2	53	25	60	25	78	80

Note - Circuit 1 Minimum Circuit Ampacity includes the Blower Motor Full Load Amps.

1. Electric heater capacity only - does not include additional blower motor heat capacity.

2. Refer to National or Canadian Electrical Code manual to determine wire, fuse and disconnect size requirements. Use wires suitable for at least 167°F.

3. HACR type breaker or fuse.

4. **Bold indicates that the circuit breaker must be replaced with size shown.**

ELECTRIC HEAT DATA - HMA30PX1S

Electric Heat Model Number	Input			Blower Motor Full Load Amps	Minimum Circuit Ampacity ²		Maximum Circuit Ampacity ³		Single Point Power Source	
	Volt	kW	Btuh ¹		Ckt 1	Ckt 2	Ckt 1	Ckt 2	Minimum Circuit Ampacity ²	Maximum Circuit Ampacity ³
5 kW ECB45-5 (27A09) Terminal Block ECB45-5CB(27A13) 30A Circuit Breaker	208	3.6	12,300	2.0	24	N/A	25⁴	N/A	N/A	N/A
	220	4.0	13,800	2.0	25	N/A	25⁴	N/A	N/A	N/A
	230	4.4	15,000	2.0	26	N/A	30	N/A	N/A	N/A
	240	4.8	16,400	2.0	28	N/A	30	N/A	N/A	N/A
7.5 kW ECB45-7.5 (27A10) Terminal Block ECB45-7.5CB(27A14) 45A Circuit Breaker	208	5.6	19,200	2.0	36	N/A	40⁴	N/A	N/A	N/A
	220	6.3	21,500	2.0	38	N/A	40⁴	N/A	N/A	N/A
	230	6.9	23,500	2.0	40	N/A	40⁴	N/A	N/A	N/A
	240	7.5	25,600	2.0	42	N/A	45	N/A	N/A	N/A
10 kW ECB45-10 (27A11) Terminal Block ECB45-10CB(27A15) 60A Circuit Breaker	208	7.2	24,600	2.0	46	N/A	50⁴	N/A	N/A	N/A
	220	8.0	27,500	2.0	48	N/A	50⁴	N/A	N/A	N/A
	230	8.8	30,000	2.0	50	N/A	50⁴	N/A	N/A	N/A
	240	9.6	32,700	2.0	53	N/A	60	N/A	N/A	N/A
12.5 kW ECB45-12.5CB (27A16) (1) 50A and (1) 25A Circuit Breaker	208	9.4	32,000	2.0	40	19	40⁴	20 ⁴	59	60
	220	10.5	35,800	2.0	42	20	45⁴	20 ⁴	62	70
	230	11.5	39,200	2.0	44	21	45⁴	25	65	70
	240	12.5	42,600	2.0	46	22	50	25	68	70
15 kW ECB45-15CB (27A17) (1) 60A and (1) 25A Circuit Breaker	208	10.8	36,900	2.0	46	22	50⁴	25	68	70
	220	12.1	41,300	2.0	48	23	50⁴	25	71	80
	230	13.2	45,100	2.0	50	24	50⁴	25	74	80
	240	14.4	49,100	2.0	53	25	60	25	78	80

Note - Circuit 1 Minimum Circuit Ampacity includes the Blower Motor Full Load Amps.

1. Electric heater capacity only - does not include additional blower motor heat capacity.

2. Refer to National or Canadian Electrical Code manual to determine wire, fuse and disconnect size requirements. Use wires suitable for at least 167°F.

3. HACR type breaker or fuse.

4. **Bold indicates that the circuit breaker must be replaced with size shown.**



ELECTRIC HEAT DATA - HMA42PX1S

Electric Heat Model Number	Input			Blower Motor Full Load Amps	Minimum Circuit Ampacity ²		Maximum Circuit Ampacity ³		Single Point Power Source	
	Volt	kW	Btuh ¹		Ckt 1	Ckt 2	Ckt 1	Ckt 2	Minimum Circuit Ampacity ²	Maximum Circuit Ampacity ³
5 kW ECB45-5 (27A09) Terminal Block ECB45-5CB(27A13) 30A Circuit Breaker	208	3.6	12,300	2.5	25	N/A	25 ⁴	N/A	N/A	N/A
	220	4.0	13,800	2.5	26	N/A	30	N/A	N/A	N/A
	230	4.4	15,000	2.5	27	N/A	30	N/A	N/A	N/A
	240	4.8	16,400	2.5	28	N/A	30	N/A	N/A	N/A
7.5 kW ECB45-7.5 (27A10) Terminal Block ECB45-7.5CB(27A14) 45A Circuit Breaker	208	5.6	19,200	2.5	37	N/A	40 ⁴	N/A	N/A	N/A
	220	6.3	21,500	2.5	39	N/A	40 ⁴	N/A	N/A	N/A
	230	6.9	23,500	2.5	41	N/A	45	N/A	N/A	N/A
	240	7.5	25,600	2.5	42	N/A	45	N/A	N/A	N/A
10 kW ECB45-10 (27A11) Terminal Block ECB45-10CB(27A15) 60A Circuit Breaker	208	7.2	24,600	2.5	46	N/A	50 ⁴	N/A	N/A	N/A
	220	8.0	27,500	2.5	49	N/A	50 ⁴	N/A	N/A	N/A
	230	8.8	30,000	2.5	51	N/A	60	N/A	N/A	N/A
	240	9.6	32,700	2.5	53	N/A	60	N/A	N/A	N/A
12.5 kW ECB45-12.5CB (27A16) (1) 50A and (1) 25A Circuit Breaker	208	9.4	32,000	2.5	41	19	45 ⁴	20 ⁴	60	60
	220	10.5	35,800	2.5	43	20	45 ⁴	20 ⁴	63	70
	230	11.5	39,200	2.5	45	21	45 ⁴	25	66	70
	240	12.5	42,600	2.5	47	22	50	25	68	70
15 kW ECB45-15CB (27A17) (1) 60A and (1) 25A Circuit Breaker	208	10.8	36,900	2.5	46	22	50 ⁴	25	68	70
	220	12.1	41,300	2.5	49	23	50 ⁴	25	72	80
	230	13.2	45,100	2.5	51	24	60	25	75	80
	240	14.4	49,100	2.5	53	25	60	25	78	80

Note - Circuit 1 Minimum Circuit Ampacity includes the Blower Motor Full Load Amps.

1. Electric heater capacity only - does not include additional blower motor heat capacity.

2. Refer to National or Canadian Electrical Code manual to determine wire, fuse and disconnect size requirements. Use wires suitable for at least 167°F.

3. HACR type breaker or fuse.

4. **Bold indicates that the circuit breaker must be replaced with size shown.**

DIMENSIONS (IN.) - UPFLOW POSITION

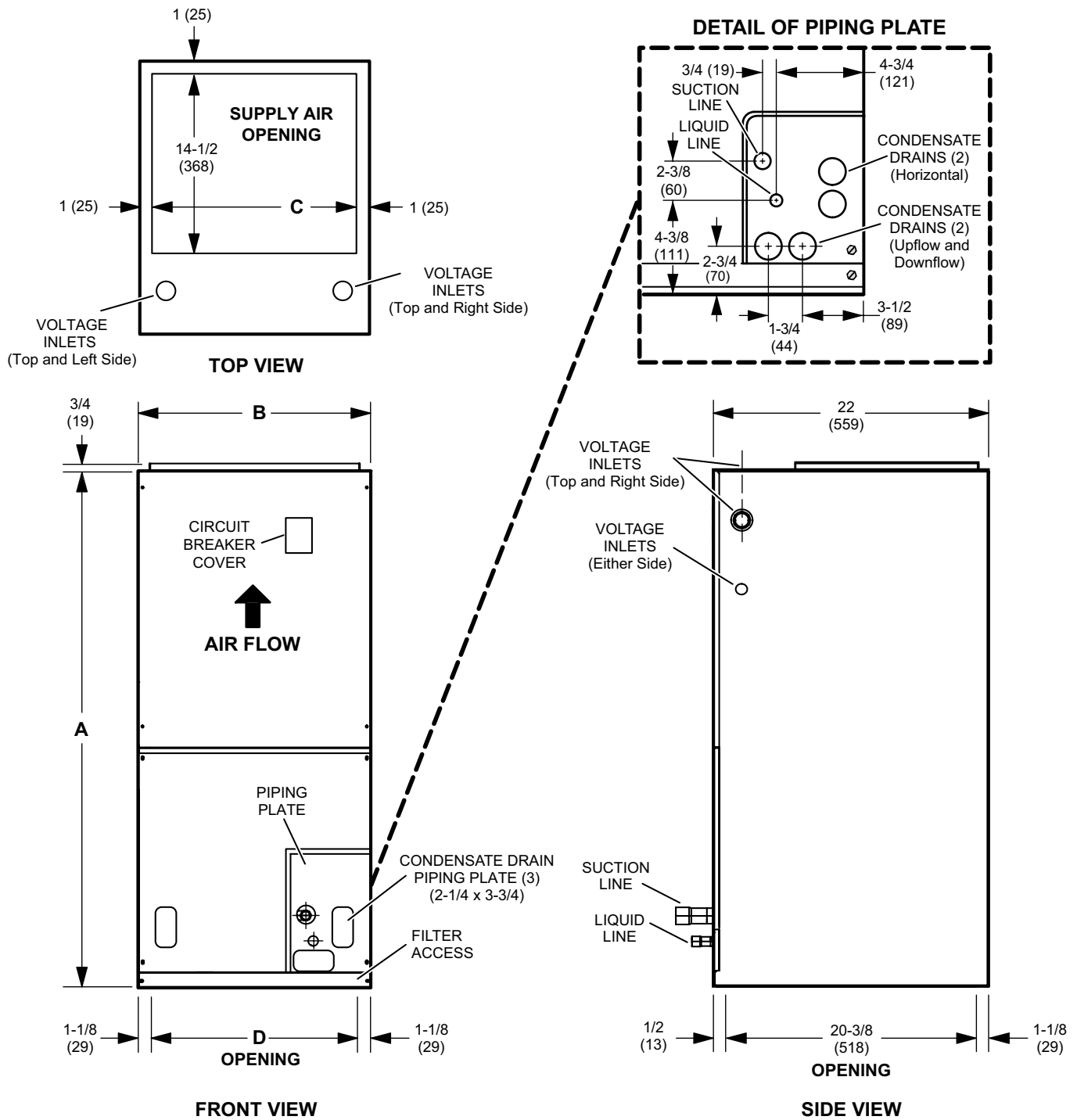

Dimensions	018		024		030		036 / 042	
	in.	mm	in.	mm	in.	mm	in.	mm
A	43-1/2	1105	45-1/2	1156	47	1194	53-5/8	1362
B	18-1/2	470	18-1/2	470	18-1/2	470	21-1/2	546
C	16-1/2	419	16-1/2	419	16-1/2	419	19-1/2	495
D	16-1/4	413	16-1/4	413	16-1/4	413	19-1/4	489

All specifications and illustrations subject to change without notice and without incurring obligations.

DIMENSIONS (IN.) - HORIZONTAL POSITION

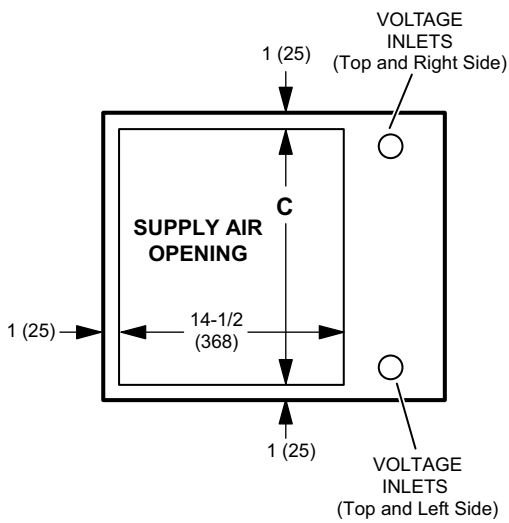
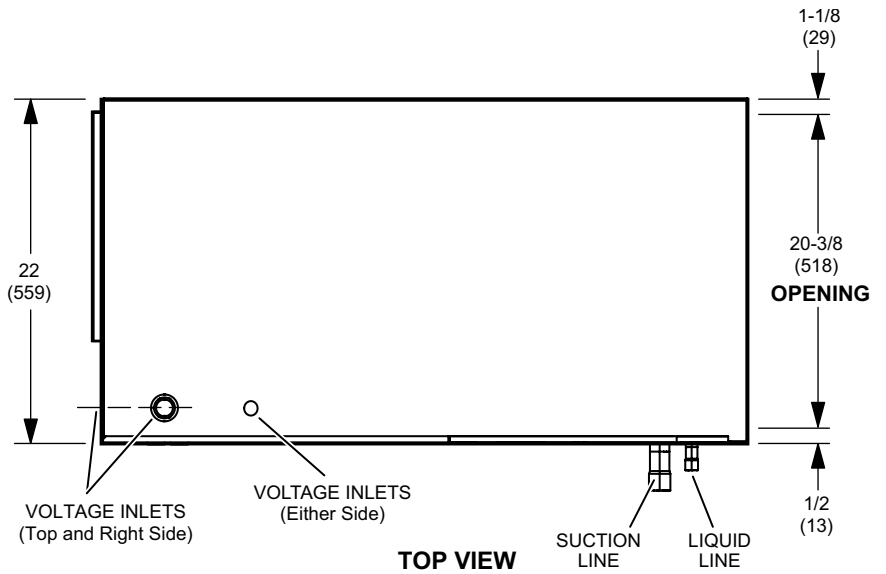
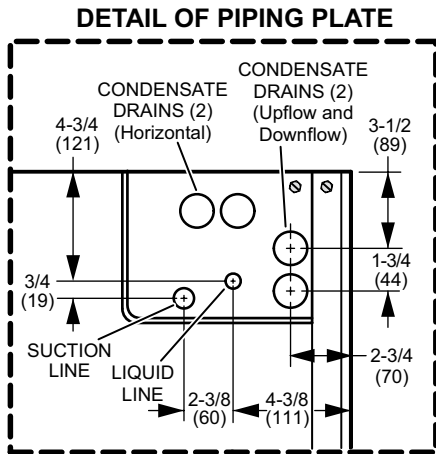

END VIEW

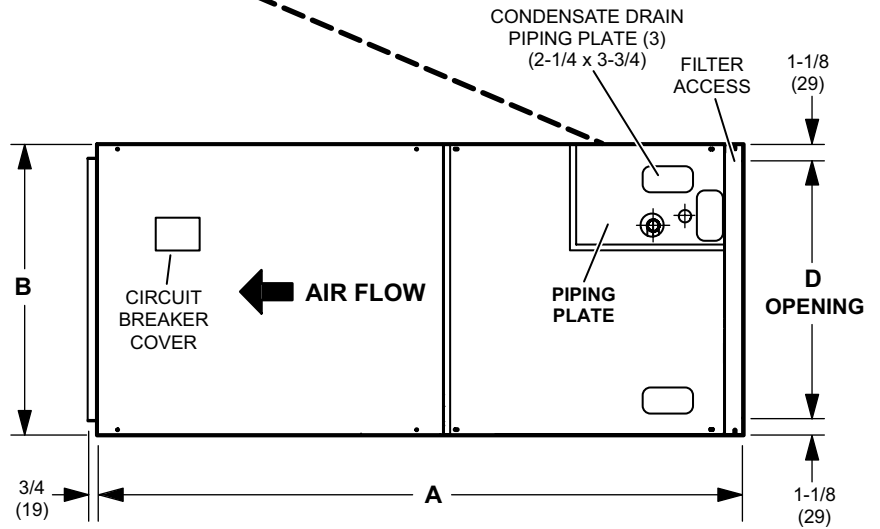

FRONT VIEW

Dimensions	018		024		030		036 / 42	
	in.	mm	in.	mm	in.	mm	in.	mm
A	43-1/2	1105	45-1/2	1156	47	1194	53-5/8	1362
B	18-1/2	470	18-1/2	470	18-1/2	470	21-1/2	546
C	16-1/2	419	16-1/2	419	16-1/2	419	19-1/2	495
D	16-1/4	413	16-1/4	413	16-1/4	413	19-1/4	489

All specifications and illustrations subject to change without notice and without incurring obligations.

DIMENSIONS (IN.) - ACCESSORIES

HORIZONTAL SUPPORT FRAME KIT

Suspension Rods (Not furnished)

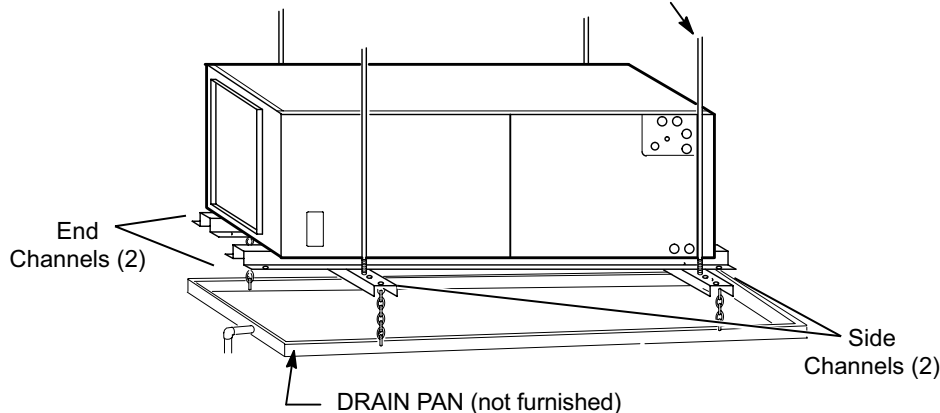

Includes (2) 1 x 1-1/2 x 32-5/8 in. side channels and (2) 1 x 3 x 53-7/8 in. end channels.

SIDE RETURN UNIT STAND (Upflow Only)

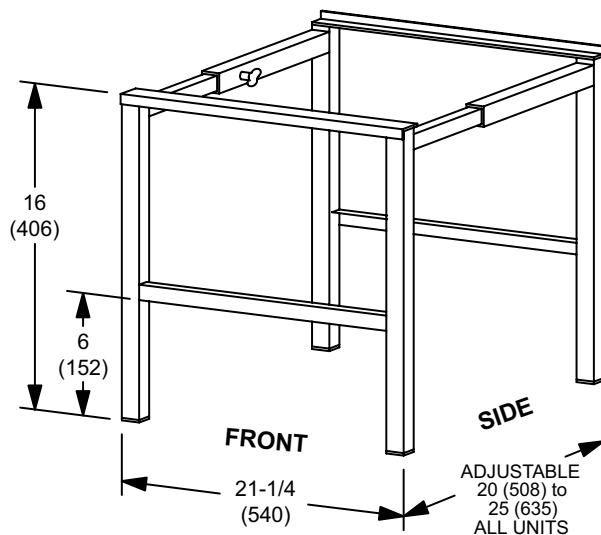

"This product complies with all California product labeling laws including, but not limited to, the Safe Drinking Water and Toxic Enforcement Act of 1986, more commonly known as Proposition 65."

Due to ongoing product improvements, specifications and dimensions are subject to change and correction without notice or incurring obligations. Determining the application and suitability for use of any product is the responsibility of the installer. Additionally, the installer is responsible for verifying dimensional data on the actual product prior to beginning any installation preparations.

Third party incentive and rebate programs have precise requirements as to product performance and certification. All products meet applicable regulations in effect on date of manufacture; however, certifications are not necessarily granted for the life of a product. Therefore, it is the responsibility of the applicant to determine whether a specific model qualifies for these incentive/rebate programs.