

SPECIFICATIONS

Approvals

- Tested with matching air conditioners and heat pump units in accordance with AHRI Standard 210/240-2023
- AHRI Certified system match-ups and expanded ratings
- ETL Listed to US and Canadian safety standards and components within are bonded for grounding to meet safety standards for servicing required by NEC and CEC
- Optional electric heaters are ETL listed and rated in accordance with US Department of Energy (DOE) test procedures and Federal Trade Commission (FTC) labeling regulations
- Blower performance data according to unit tests conducted in air test chamber
- Approved for installation in manufactured housing and mobile homes
- ISO 9001 Registered Manufacturing Quality System

Application

- 2 to 5 ton nominal sizes
- Upflow or horizontal applications
NOTE: Downflow applications require optional conversion kit
- Applicable to expansion valve systems in cooling applications and check and expansion valve systems in heat pump applications
- Wide-range R-454B check and expansion valve is factory installed
- Optional field installed electric heaters available in several sizes for additive heating capacity

Refrigerant System

- 1 Aluminum Tube and Fin Coil
 - Enhanced aluminum alloy tube/enhanced fin coil for superior corrosion resistance
 - Aluminum tubing, hairpins, distributor and header tubes.
 - Ripple-edged aluminum fins
 - Twin coil construction assembled in a "A" configuration for large surface area
 - Provides excellent heat transfer and low air resistance for maximum efficiency
 - Precise circuiting for uniform refrigerant distribution
 - Lanced fins provide maximum exposure of fin surface to air stream
 - Axial grooved tubing provides superior heat transfer
 - Coil thoroughly factory tested under high pressure to ensure leakproof construction

Refrigerant System (Continued)

- 2 Mechanical or Brazed Line Set Connections
 - Copper refrigerant sweat connections on both liquid and suction lines for easy brazing
 - Lines extend outside of the cabinet for ease of connection
 - See dimension drawings for locations

Braze-Free/Press Fitting Flexibility

- Units can accommodate braze-free or press fittings for installation versatility

- 3 R-454B Check and Expansion Valve

- For use with R-454B systems
- Wide range valve with Chatleff style fitting
- Factory installed on all models, internal to cabinet

HMA-C SERIES

ENHANCED AIR HANDLER

**Multi-position
TXV Furnished
Constant Torque Motor
2 - 5 Tons**



Warranty—6 years on parts
(Some limitations apply; see printed warranty for details.)
www.century-hvac.com



Refrigerant Detection System (RDS)

- Complies with UL 60335-2-40 approved standard
- Required for all systems using R-454B refrigerant
- Consists of a factory installed Refrigerant Detection System (RDS) sensor and a Refrigerant Detection System (RDS) Blower Control Board

Refrigerant Detection System (RDS) Air Handler Sensor

- Sensor ensures safe operation for systems equipped with R-454B refrigerant
- Indoor sensor will detect any R-454B refrigerant
NOTE: Sensor must be repositioned for horizontal-right, horizontal-left, and downflow applications.

Blower Control Board

- Connected to the RDS sensor
- Used as interface between indoor unit and thermostat to control system
- Ensures safe operation for systems equipped with R-454B refrigerant
- If R-454B refrigerant is detected, the refrigerant detection system will stop compressor and/or heating operation and operate the blower to reduce concentrations in the conditioned space
- Once safe levels are reached the HVAC system will resume normal operation
- Multi-color LED for system status and as an aid in troubleshooting
- Flashing LED codes for system status (Green/Blue) and diagnosing Sensor errors (Red)
- Alarm relay can trigger an external alarm if a leak is detected
- Zone relay opens all zone dampers (if part of a zoning system) if R-454B refrigerant is detected
- Power is disabled to thermostat to prevent demand if R-454B refrigerant is detected
- On system start-up blower will run for five minutes and any thermostat demands are disabled
NOTE: Refer to the Installation Instructions for additional information

4 Blower

Constant Torque Blower Motor

- Programmable high efficiency multi-speed blower motor
- By maintaining constant torque output, blower motor can deliver more uniform (but not constant) airflow over the static pressure range
- Programmable operation is achieved by the use of an ECM (Electronically Commutated Motor) motor
- Leadless blower motor features simple plug-in connections
- Choice of blower speeds is available
- See blower Data tables
- Blower speed change is easily accomplished by a simple wiring change

Blower Assembly

- Each blower is statically and dynamically balanced as an assembly before installation in the unit
- Blower motor is resiliently mounted to blower assembly
- Blower slides out of cabinet for servicing

5 Cabinet

- Constructed of heavy gauge galvanized steel
- Pre-painted cabinet finish
- Completely insulated with foil faced fiberglass insulation
- Removable panels provide complete service access
- Filter access door for easy filter replacement
- Thumbscrews hold filter door in place
- Electrical inlets provided in sides and top of cabinet

- See dimension drawing for locations
- Plugs in cabinet for drain connections for upflow (left and right) and horizontal applications
- See dimension drawing

Low Leakage Cabinet

- All models have less than 2% air leakage and meet ANSI/ASHRAE Standard 193-2010 "Method of Test for Determining the Air Tightness of HVAC Equipment"

Upflow/Horizontal Capability (Optional Downflow)

- Shipped for upflow and horizontal right-hand discharge
- May be field converted to horizontal left-hand air discharge by repositioning horizontal drain pan
- Optional downflow kit required for field conversion

Optional Accessories

Downflow Conversion Kit

- Required for field conversion to downflow position
- Kit consists of insulated downflow drain pan, insulated drain pan drip shields, coil drip shields, seal plates and support brackets for repositioning coil and drain pan

Horizontal Support Frame Kit

- Provides support of unit in horizontal applications
- Consists of (2) 1 x 1-1/2 x 32-5/8 in. and (2) 1 x 3 x 53-7/8 in. painted heavy gauge cold rolled steel support channels with assembly and suspending holes
- Bolts and nuts furnished for field assembly
- Suspending rods must be field provided

Side Return Unit Stand (Upflow Only)

- Raises unit 16 in. above floor for side return air duct connection
- Eliminates need for wooden platform construction
- All aluminum construction
- Two adjustable frames fit all sizes

Wall Hanging Bracket Kit (Upflow Only)

- Allows unit to be hung on wall at any height
- Consists of heavy-gauge steel support brackets (one for air handler, one for wall mount)
- Screws furnished for fastening one bracket to unit
- Bolts for fastening one bracket to wall are field provided

High Performance Economizer (Commercial Applications Only)

- Designed for applications requiring outdoor air to be utilized in a commercial HVAC system
- Allows the entry of fresh outdoor air for free cooling, reducing the requirement for mechanical cooling
- Heavy gauge galvanized steel cabinet lined with thick fiberglass insulation
- Mixed air sensor, outdoor air sensor and 24VAC transformer furnished
- Approved for California Title 24 building standards
- ASHRAE 90.1-2010 compliant

6 Anti-Microbial Dual Position Drain Pans

- Anti-Microbial additive resists growth of mold and mildew on drain pan which improves indoor air quality and reduces drain line blockage
- Drain pans designed for upflow or horizontal applications
- Deep, corrosion resistant high temperature engineered polymer drain pans have dual pipe drains
- See dimension drawing

7 Filter

- Disposable 1 inch filter is furnished
- Filter rack furnished in cabinet for easy filter installation
- See Specifications tables for filter sizes

8 Transformer

- 24 volt transformer furnished as standard
- Factory installed in the unit control box

9 Optional Electric Heat

- ETL listed
- Field install internal to unit cabinet
- Available in several kW sizes
- See Electric Heat tables
- Helix wound nichrome heating elements exposed directly in air stream resulting in instant heat transfer, low element temperatures and long service life
- Each element equipped with accurately located limit control with fixed temperature off setting and automatic reset
- Thermal sequencer relay brings elements on and off line, in sequence and equal increments, with time delay between each
- Heating control relay(s) furnished as standard
- Factory assembled with controls installed and wired
- Electric heat control wiring plugs into mating connector on air handler unit

Circuit Breaker (CB) Models

- All "CB" model heaters are equipped with circuit breakers for overload and short circuit protection
- Factory wired and mounted on electric heat unit
- Current sensitive and temperature actuated
- Manual reset
- Flexible plastic circuit breaker cover protects circuit breaker in areas with high humidity or unconditioned areas to prevent nuisance tripping
- Circuit breakers qualify as disconnect means at unit in many areas, eliminate the need for field provided disconnect
- Consult local electrical code in your area

Optional Accessories

Single-Point Power Source Control Box

- Control Box may be used with optional electric heat when single power supply is connected to multi-circuit electric heat
- Field installs external to the unit cabinet on either side or top
- Constructed of heavy gauge steel, baked enamel finish, pre-punched mounting holes, electrical inlet knockouts, and terminal strip
- Removeable cover provides easy access
- Dimensions (H x W x D) - 7 x 7 x 4 in.

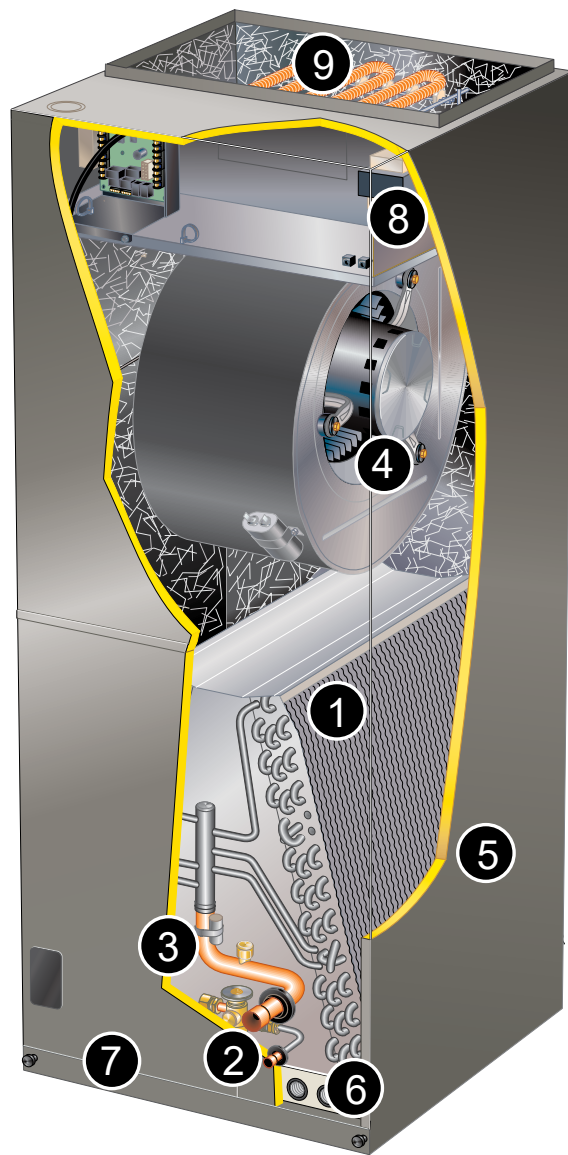

 **Century**®

MODEL NUMBER GUIDE

H	M	A	18	C	X	1	S
Air Handler	Multi-Position	R-454B	Capacity BTUH x 1000	Constant Torque Motor	TXV Included	Power 1 = 208/230-1-60	Series

PHYSICAL

Model		HMA24CX1S	HMA30CX1S	HMA36CX1S	HMA42CX1S	HMA48CX1S	HMA60CX1S
Nominal Tonnage		2	2.5	3	3.5	4	5
Refrigerant Type		R-454B	R-454B	R-454B	R-454B	R-454B	R-454B
Connections	Liquid line (OD) sweat - in.	3/8	3/8	3/8	3/8	3/8	3/8
	Suction line (OD) sweat - in.	3/4	3/4	7/8	7/8	7/8	7/8
	Condensate drain (FPT) - in.	(2) 3/4	(2) 3/4	(2) 3/4	(2) 3/4	(2) 3/4	(2) 3/4
Indoor Coil	Net face area - ft. ²	3.77	4.72	5.66	5.66	6.13	7.08
	Tube diameter - in.	3/8	3/8	3/8	3/8	3/8	3/8
	Rows	3	3	3	3	3	3
	Fins - in.	15	15	15	15	15	15
Blower	HP	1/2	1/2	1/2	3/4	1	1
	Wheel nominal diameter x width - in.	10 x 8	10 x 8	10 x 8	12 x 10	12 x 10	12 x 10
	Air volume range - in.	203 - 1054	406 - 1341	422 - 1523	568 - 1656	1110 - 1895	830 - 1980
Filters ¹		15 x 20 x 1	15 x 20 x 1	18 x 20 x 1	18 x 20 x 1	18 x 20 x 1	18 x 20 x 1
Shipping Data - lbs.		127	133	169	169	179	190

ELECTRICAL

Model	HMA24CX1S	HMA30CX1S	HMA36CX1S	HMA42CX1S	HMA48CX1S	HMA60CX1S
Line voltage date (Volts-Phase-Hz)	208/230-1-60	208/230-1-60	208/230-1-60	208/230-1-60	208/230-1-60	208/230-1-60
Maximum overcurrent protection (MOCP) amps (unit) ²	15	15	15	15	15	15
Minimum circuit ampacity (MCA) (unit) ³	5	5	5	8	9.5	9.5
Blower Motor Full Load Amps	4.1	4.1	4.1	6	7.6	7.6

1. Disposable filter.

2. HACR type circuit breaker or fuse.

3. Refer to National or Canadian Electrical Code manual to determine wire, fuse and disconnect size requirements. Use wires suitable for at least 167°F.

ACCESSORIES

DESCRIPTION	WHERE USED	KIT NUMBER
Down-flow Conversion Kit	24, 30	Y9658
	36, 42, 48, 60	Y9659
Horizontal Support Frame kit	All Models	56J18
Side Return Unit Stand (upflow only)	All Models	45K32
Single Point Power Source Control Box (For Electric Heat)	All Models	21H39
Wall Hanging Bracket Kit (upflow only)	All Models	45K30
High Performance Economizer (Commercial Only)	All Models	10U53

REPLACEMENT CIRCUIT BREAKERS

Voltage	Description	Order Number
208/240V - 1 Phase	25 amp, 2 pole	41K13
	30 amp, 2 pole	17K70
	35 amp, 2 pole	72K07
	40 amp, 2 pole	49K14
	45 amp, 2 pole	17K71
	50 amp, 2 pole	41K12
	60 amp, 2 pole	17K72

INSTALLATION CLEARANCES WITH ELECTRIC HEAT	
Cabinet	0 inch (0mm)
To Penum	0 inch (0mm)
To Outlet Duct	0 inch (0mm)
Floor	0 inch (0mm)
Service / Maintenance	See Note #1

1. Front Service Access - 24 inches (610mm).

NOTE - If cabinet depth is more than 24 inches (610mm), allow a minimum of cabinet depth plus 2 inches (51mm)

HMA24CX1S PERFORMANCE

External Static Pressure in w.g.	Air Volume / Watts at Various Blower Speeds									
	Tap 1		Tap 2		Tap 3		Tap 4		Tap 5	
	CFM	Watts	CFM	Watts	CFM	Watts	CFM	Watts	CFM	Watts
0.10	676	64	820	107	1015	180	1015	180	1054	194
0.20	612	71	780	114	981	188	981	188	1020	203
0.30	514	77	752	120	953	195	953	195	987	212
0.40	448	83	712	126	922	204	922	204	958	219
0.50	400	86	678	133	899	210	899	210	940	226
0.60	337	92	598	142	865	219	865	219	902	235
0.70	270	100	535	147	831	224	831	224	881	241
0.80	203	103	495	153	799	237	799	237	833	248

HMA30CX1S PERFORMANCE

External Static Pressure in w.g.	Air Volume / Watts at Various Blower Speeds									
	Tap 1		Tap 2		Tap 3		Tap 4		Tap 5	
	CFM	Watts	CFM	Watts	CFM	Watts	CFM	Watts	CFM	Watts
0.10	775	87	999	160	1132	219	1132	219	1341	346
0.20	731	94	965	168	1099	229	1099	229	1309	357
0.30	690	100	936	175	1068	237	1068	237	1289	364
0.40	647	106	899	184	1041	245	1041	245	1259	376
0.50	565	115	870	191	1014	254	1014	254	1239	285
0.60	522	118	833	197	985	261	985	261	1197	389
0.70	474	125	797	208	957	269	957	269	1168	395
0.80	406	132	715	218	928	278	928	278	1139	403

HMA36CX1S PERFORMANCE

External Static Pressure in w.g.	Air Volume / Watts at Various Blower Speeds									
	Tap 1		Tap 2		Tap 3		Tap 4		Tap 5	
	CFM	Watts	CFM	Watts	CFM	Watts	CFM	Watts	CFM	Watts
0.10	865	94	1303	250	1415	312	1415	312	1523	386
0.20	812	104	1268	261	1381	325	1381	325	1492	399
0.30	747	113	1234	271	1352	336	1352	336	1464	411
0.40	674	119	1119	283	1316	348	1316	348	1434	423
0.50	620	125	1153	295	1285	360	1285	360	1403	434
0.60	565	131	1117	306	1238	377	1238	377	1363	425
0.70	484	138	1047	323	1202	386	1202	386	1315	456
0.80	422	144	1004	326	1134	396	1134	396	1281	467

NOTE - All air data measured external to unit with dry coil and 1 inch non-pleated air filter in place.
Electric heaters have no appreciable air resistance.

HMA42CX1S PERFORMANCE

External Static Pressure in w.g.	Air Volume / Watts at Various Blower Speeds									
	Tap 1		Tap 2		Tap 3		Tap 4		Tap 5	
	CFM	Watts	CFM	Watts	CFM	Watts	CFM	Watts	CFM	Watts
0.10	982	132	820	1446	390	1560	473	1560	1656	569
0.20	923	140	1413	402	1526	488	1526	488	1624	581
0.30	866	148	1362	411	1500	498	1500	498	1594	591
0.40	812	153	1357	420	1469	510	1469	510	1563	602
0.50	745	162	1325	429	1437	520	1437	520	1543	613
0.60	686	169	1292	438	1413	530	1413	530	1505	615
0.70	642	176	1257	448	1345	543	1345	543	1456	613
0.80	568	185	1221	458	1335	544	1335	544	1417	612

HMA48CX1S PERFORMANCE

External Static Pressure in w.g.	Air Volume / Watts at Various Blower Speeds									
	Tap 1		Tap 2		Tap 3		Tap 4		Tap 5	
	CFM	Watts	CFM	Watts	CFM	Watts	CFM	Watts	CFM	Watts
0.10	1277	187	1524	279	1733	395	1733	426	1899	512
0.20	1234	197	1480	295	1697	410	1741	443	1867	530
0.30	1190	208	1442	307	1661	424	1704	460	1837	544
0.40	1145	217	1400	321	1629	437	1678	482	1806	559
0.50	1099	229	1348	332	1597	449	1645	486	1775	574
0.60	1011	243	1323	344	1552	466	1612	500	1745	588
0.70	934	252	1284	356	1519	478	1577	514	1710	604
0.80	896	258	1212	372	1482	491	1546	525	1680	616
0.90	845	272	1129	385	1451	502	1509	539	1644	632

HMA60CX1S PERFORMANCE

External Static Pressure in w.g.	Air Volume / Watts at Various Blower Speeds									
	Tap 1		Tap 2		Tap 3		Tap 4		Tap 5	
	CFM	Watts	CFM	Watts	CFM	Watts	CFM	Watts	CFM	Watts
0.10	1147	144	1673	387	1826	496	1903	553	2010	630
0.20	1085	155	1630	402	1791	512	1876	566	1976	642
0.30	1035	164	1596	415	1762	525	1843	583	1947	656
0.40	1006	171	1563	428	1732	538	1825	596	1912	672
0.50	954	180	1526	443	1704	551	1782	613	1883	683
0.60	825	194	1495	455	1669	567	1750	627	1851	701
0.70	783	199	1464	467	1637	582	1722	641	1821	715
0.80	739	208	1436	477	1602	597	1691	655	1776	717
0.90	687	219	1406	488	1583	604	1643	656	1745	722

NOTE - All air data measured external to unit with dry coil and 1 inch non-pleated air filter in place.
Electric heaters have no appreciable air resistance.

ELECTRIC HEAT DATA - HMA24CX1S

Electric Heat Model Number	Input			Blower Motor Full Load Amps	Minimum Circuit Ampacity ²	Maximum Circuit Ampacity ³
	Volt	kW	Btuh ¹			
5 kW ECB45-5 (27A09) Terminal Block ECB45-5CB(27A13) 30A Circuit Breaker	208	3.6	12,300	4.1	27	30
	220	4.0	13,800	4.1	28	30
	230	4.4	15,000	4.1	29	30
	240	4.8	16,400	4.1	30	30
7.5 kW ECB45-7.5 (27A10) Terminal Block ECB45-7.5CB(27A14) 30A Circuit Breaker	208	5.6	19,200	4.1	39	40⁴
	220	6.3	21,500	4.1	41	45
	230	6.9	23,500	4.1	43	45
	240	7.5	25,600	4.1	44	45
10 kW ECB45-10 (27A11) Terminal Block ECB45-10CB(27A15) 30A Circuit Breaker	208	7.2	24,600	4.1	48	50⁴
	220	8.0	27,500	4.1	51	60
	230	8.8	30,000	4.1	53	60
	240	9.6	32,700	4.1	55	60

ELECTRIC HEAT DATA - HMA30CX1S

Electric Heat Model Number	Input			Blower Motor Full Load Amps	Minimum Circuit Ampacity ²		Maximum Circuit Ampacity ³		Single Point Power Source	
	Volt	kW	Btuh ¹		Ckt 1	Ckt 2	Ckt 1	Ckt 2	Minimum Circuit Ampacity ²	Maximum Circuit Ampacity ³
5 kW ECB45-5 (27A09) Terminal Block ECB45-5CB(27A13) 30A Circuit Breaker	208	3.6	12,300	4.1	27	N/A	30	N/A	N/A	N/A
	220	4.0	13,800	4.1	28	N/A	30	N/A	N/A	N/A
	230	4.4	15,000	4.1	29	N/A	30	N/A	N/A	N/A
	240	4.8	16,400	4.1	30	N/A	30	N/A	N/A	N/A
7.5 kW ECB45-7.5 (27A10) Terminal Block ECB45-7.5CB(27A14) 45A Circuit Breaker	208	5.6	19,200	4.1	39	N/A	40⁴	N/A	N/A	N/A
	220	6.3	21,500	4.1	41	N/A	45	N/A	N/A	N/A
	230	6.9	23,500	4.1	43	N/A	45	N/A	N/A	N/A
	240	7.5	25,600	4.1	44	N/A	45	N/A	N/A	N/A
10 kW ECB45-10 (27A11) Terminal Block ECB45-10CB(27A15) 60A Circuit Breaker	208	7.2	24,600	4.1	48	N/A	50⁴	N/A	N/A	N/A
	220	8.0	27,500	4.1	51	N/A	60	N/A	N/A	N/A
	230	8.8	30,000	4.1	53	N/A	60	N/A	N/A	N/A
	240	9.6	32,700	4.1	55	N/A	60	N/A	N/A	N/A
12.5 kW ECB45-12.5CB (27A16) (1) 50A and (1) 25A Circuit Breaker	208	9.4	32,000	4.1	43	19	45⁴	20⁴	62	70
	220	10.5	35,800	4.1	45	20	45⁴	20⁴	65	70
	230	11.5	39,200	4.1	47	21	50	25	68	70
	240	12.5	42,600	4.1	49	22	50	25	70	70
15 kW ECB45-15CB (27A17) (1) 60A and (1) 25A Circuit Breaker	208	10.8	36,900	4.1	48	22	50⁴	25	70	70
	220	12.1	41,300	4.1	51	23	60	25	74	80
	230	13.2	45,100	4.1	53	24	60	25	77	80
	240	14.4	49,100	4.1	55	25	60	25	80	80

Note - Circuit 1 Minimum Circuit Ampacity includes the Blower Motor Full Load Amps.

1. Electric heater capacity only - does not include additional blower motor heat capacity.

2. Refer to National or Canadian Electrical Code manual to determine wire, fuse and disconnect size requirements. Use wires suitable for at least 167°F.

3. HACR type breaker or fuse.

4. **Bold indicates that the circuit breaker must be replaced with size shown.**

ELECTRIC HEAT DATA - HMA36CX1S

Electric Heat Model Number		Input			Blower Motor Full Load Amps	Minimum Circuit Ampacity ²		Maximum Circuit Ampacity ³		Single Point Power Source	
		Volt	kW	Btuh ¹		Ckt 1	Ckt 2	Ckt 1	Ckt 2	Minimum Circuit Ampacity ²	Maximum Circuit Ampacity ³
5 kW	ECB45-5 (27A09) Terminal Block	208	3.6	12,300	4.1	27	N/A	30	N/A	N/A	N/A
		220	4.0	13,800	4.1	28	N/A	30	N/A	N/A	N/A
	ECB45-5CB(27A13) 30A Circuit Breaker	230	4.4	15,000	4.1	29	N/A	30	N/A	N/A	N/A
		240	4.8	16,400	4.1	30	N/A	30	N/A	N/A	N/A
7.5 kW	ECB45-7.5 (27A10) Terminal Block	208	5.6	19,200	4.1	39	N/A	40⁴	N/A	N/A	N/A
		220	6.3	21,500	4.1	41	N/A	45	N/A	N/A	N/A
	ECB45-7.5CB(27A14) 45A Circuit Breaker	230	6.9	23,500	4.1	43	N/A	45	N/A	N/A	N/A
		240	7.5	25,600	4.1	44	N/A	45	N/A	N/A	N/A
10 kW	ECB45-10 (27A11) Terminal Block	208	7.2	24,600	4.1	48	N/A	50⁴	N/A	N/A	N/A
		220	8.0	27,500	4.1	51	N/A	60	N/A	N/A	N/A
	ECB45-10CB(27A15) 60A Circuit Breaker	230	8.8	30,000	4.1	53	N/A	60	N/A	N/A	N/A
		240	9.6	32,700	4.1	55	N/A	60	N/A	N/A	N/A
12.5 kW	ECB45-12.5CB (27A16) (1) 50A and (1) 25A Circuit Breaker	208	9.4	32,000	4.1	43	19	45⁴	20⁴	62	70
		220	10.5	35,800	4.1	45	20	45⁴	20⁴	65	70
		230	11.5	39,200	4.1	47	21	50	25	68	70
		240	12.5	42,600	4.1	49	22	50	25	70	70
15 kW	ECB45-15CB (27A17) (1) 60A and (1) 25A Circuit Breaker	208	10.8	36,900	4.1	48	22	50⁴	25	70	70
		220	12.1	41,300	4.1	51	23	60	25	75	80
		230	13.2	45,100	4.1	53	24	60	25	77	80
		240	14.4	49,100	4.1	55	25	60	25	80	80

ELECTRIC HEAT DATA - HMA42CX1S

Electric Heat Model Number		Input			Blower Motor Full Load Amps	Minimum Circuit Ampacity ²		Maximum Circuit Ampacity ³		Single Point Power Source	
		Volt	kW	Btuh ¹		Ckt 1	Ckt 2	Ckt 1	Ckt 2	Minimum Circuit Ampacity ²	Maximum Circuit Ampacity ³
5 kW	ECB45-5 (27A09) Terminal Block	208	3.6	12,300	6.0	29	N/A	30	N/A	N/A	N/A
		220	4.0	13,800	6.0	30	N/A	30	N/A	N/A	N/A
	ECB45-5CB(27A13) 30A Circuit Breaker	230	4.4	15,000	6.0	31	N/A	35⁴	N/A	N/A	N/A
		240	4.8	16,400	6.0	33	N/A	35⁴	N/A	N/A	N/A
7.5 kW	ECB45-7.5 (27A10) Terminal Block	208	5.6	19,200	6.0	41	N/A	45	N/A	N/A	N/A
		220	6.3	21,500	6.0	43	N/A	45	N/A	N/A	N/A
	ECB45-7.5CB(27A14) 45A Circuit Breaker	230	6.9	23,500	6.0	45	N/A	45	N/A	N/A	N/A
		240	7.5	25,600	6.0	47	N/A	50⁴	N/A	N/A	N/A
10 kW	ECB45-10 (27A11) Terminal Block	208	7.2	24,600	6.0	51	N/A	60	N/A	N/A	N/A
		220	8.0	27,500	6.0	53	N/A	60	N/A	N/A	N/A
	ECB45-10CB(27A15) 60A Circuit Breaker	230	8.8	30,000	6.0	55	N/A	60	N/A	N/A	N/A
		240	9.6	32,700	6.0	58	N/A	60	N/A	N/A	N/A
12.5 kW	ECB45-12.5CB (27A16) (1) 50A and (1) 25A Circuit Breaker	208	9.4	32,000	6.0	45	19	45⁴	20⁴	64	70
		220	10.5	35,800	6.0	47	20	50	20⁴	67	70
		230	11.5	39,200	6.0	49	21	50	25	70	70
		240	12.5	42,600	6.0	51	22	60⁴	25	73	80
15 kW	ECB45-15CB (27A17) (1) 60A and (1) 25A Circuit Breaker	208	10.8	36,900	6.0	51	22	60	25	73	80
		220	12.1	41,300	6.0	53	23	60	25	76	80
		230	13.2	45,100	6.0	55	24	60	25	79	80
		240	14.4	49,100	6.0	58	25	60	25	83	90

Note - Circuit 1 Minimum Circuit Ampacity includes the Blower Motor Full Load Amps.

1. Electric heater capacity only - does not include additional blower motor heat capacity.

2. Refer to National or Canadian Electrical Code manual to determine wire, fuse and disconnect size requirements. Use wires suitable for at least 167°F.

3. HACR type breaker or fuse.

4. **Bold indicates that the circuit breaker must be replaced with size shown.**

ELECTRIC HEAT DATA - HMA48CX1S/HMA60CX1S

Electric Heat Model Number	Input			Blower Motor Full Load Amps	Minimum Circuit Ampacity ²		Maximum Circuit Ampacity ³		Single Point Power Source	
	Volt	kW	Btuh ¹		Ckt 1	Ckt 2	Ckt 1	Ckt 2	Minimum Circuit Ampacity ²	Maximum Circuit Ampacity ³
5 kW ECB25-5 (27A09) Terminal Block ECB25-5CB(16Y39) 30A Circuit Breaker	208	3.6	12,300	7.6	31	N/A	35⁴	N/A	N/A	N/A
	220	4.0	13,800	7.6	32	N/A	35⁴	N/A	N/A	N/A
	230	4.4	15,000	7.6	33	N/A	35⁴	N/A	N/A	N/A
	240	4.8	16,400	7.6	35	N/A	35⁴	N/A	N/A	N/A
7.5 kW ECB25-7.5 (27A10) Terminal Block ECB25-7.5CB(16Y41) 45A Circuit Breaker	208	5.6	19,200	7.6	43	N/A	45	N/A	N/A	N/A
	220	6.3	21,500	7.6	45	N/A	45	N/A	N/A	N/A
	230	6.9	23,500	7.6	47	N/A	50⁴	N/A	N/A	N/A
	240	7.5	25,600	7.6	49	N/A	50⁴	N/A	N/A	N/A
10 kW ECB25-10 (27A11) Terminal Block ECB25-10CB(16Y42) 60A Circuit Breaker	208	7.2	24,600	7.6	53	N/A	60	N/A	N/A	N/A
	220	8.0	27,500	7.6	55	N/A	60	N/A	N/A	N/A
	230	8.8	30,000	7.6	57	N/A	60	N/A	N/A	N/A
	240	9.6	32,700	7.6	60	N/A	60	N/A	N/A	N/A
12.5 kW ECB25-12.5 (27A16) (1)50A and (1) 25A Circuit Breaker	208	9.4	32,000	7.6	47	19	50	20⁴	66	70
	220	10.5	35,800	7.6	49	20	50	20⁴	69	70
	230	11.5	39,200	7.6	51	21	60⁴	25	72	80
	240	12.5	42,600	7.6	53	22	60⁴	25	75	80
15 kW ECB25-15 (27A17) (1)60A and (1) 25A Circuit Breaker	208	10.8	36,900	7.6	53	22	60	25	75	80
	220	12.1	41,300	7.6	55	23	60	25	78	80
	230	13.2	45,100	7.6	57	24	60	25	81	90
	240	14.4	49,100	7.6	60	25	60	25	85	90
20 kW ECB25-20 (27A18) (1)60A and (1) 50A Circuit Breaker	208	14.4	49,200	7.6	53	43	60	45⁴	96	100
	220	16.1	55,000	7.6	55	46	60	50	101	110
	230	17.6	60,100	7.6	57	48	60	50	105	110
	240	19.2	65,500	7.6	60	50	60	50	110	110

Note - Circuit 1 Minimum Circuit Ampacity includes the Blower Motor Full Load Amps.

1. Electric heater capacity only - does not include additional blower motor heat capacity.

2. Refer to National or Canadian Electrical Code manual to determine wire, fuse and disconnect size requirements. Use wires suitable for at least 167°F.

3. HACR type breaker or fuse.

4. **Bold indicates that the circuit breaker must be replaced with size shown.**



DIMENSIONS (IN.) - UPFLOW POSITION

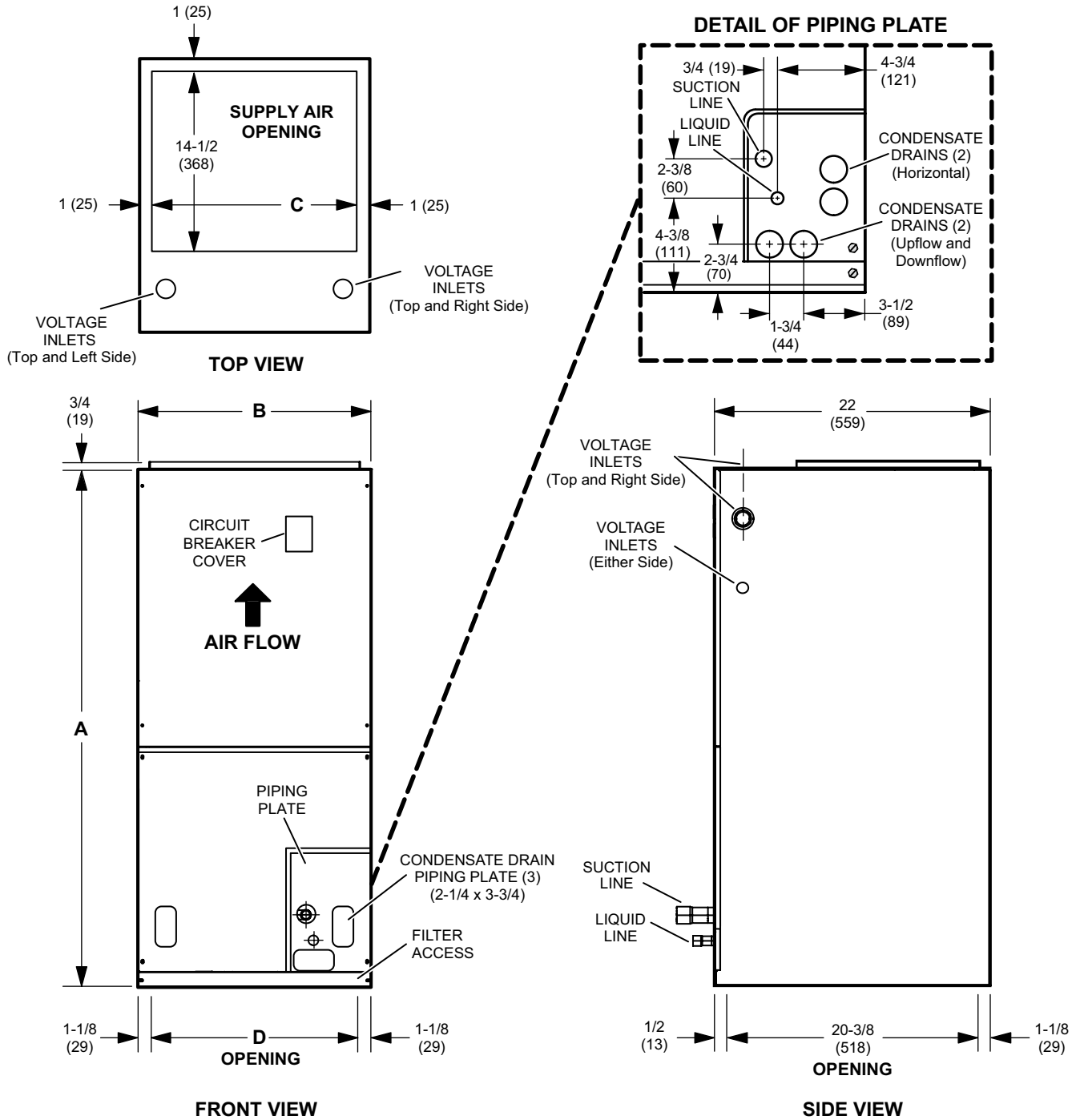

Dimensions	024		030		036 / 042		048		060	
	in.	mm	in.	mm	in.	mm	in.	mm	in.	mm
A	45-1/2	1156	47	1194	53-5/8	1362	55	1397	59-3/4	1518
B	18-1/2	470	18-1/2	470	21-1/2	546	21-1/2	546	21-1/2	546
C	16-1/2	419	16-1/2	419	19-1/2	495	19-1/2	495	19-1/2	495
D	16-1/4	413	16-1/4	413	19-1/4	489	19-1/4	489	19-1/4	489

All specifications and illustrations subject to change without notice and without incurring obligations.

DIMENSIONS (IN.) - HORIZONTAL POSITION

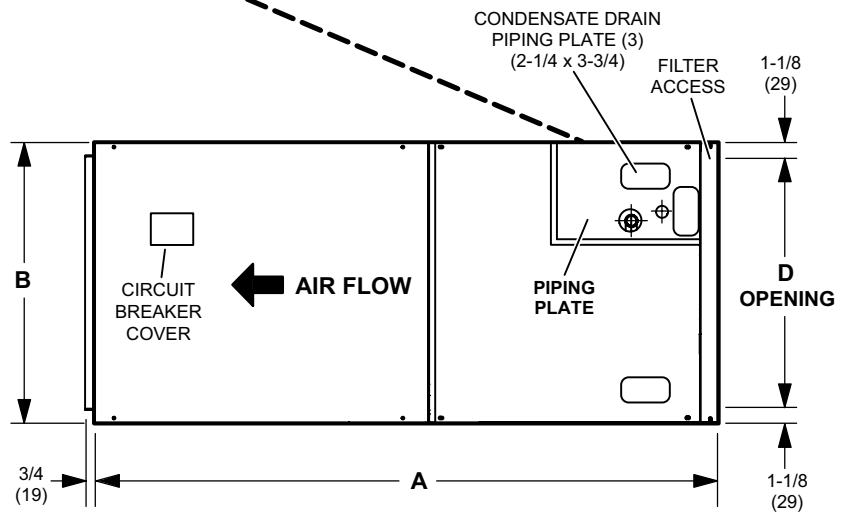
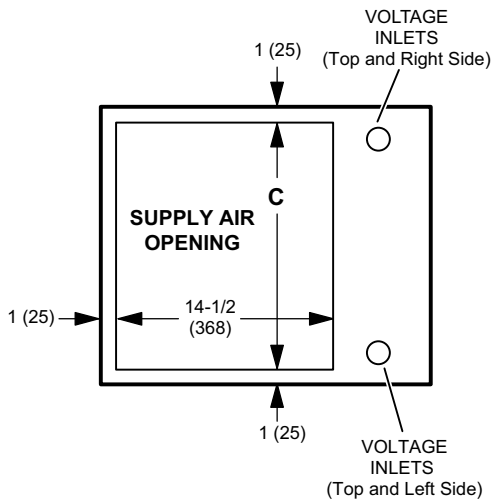
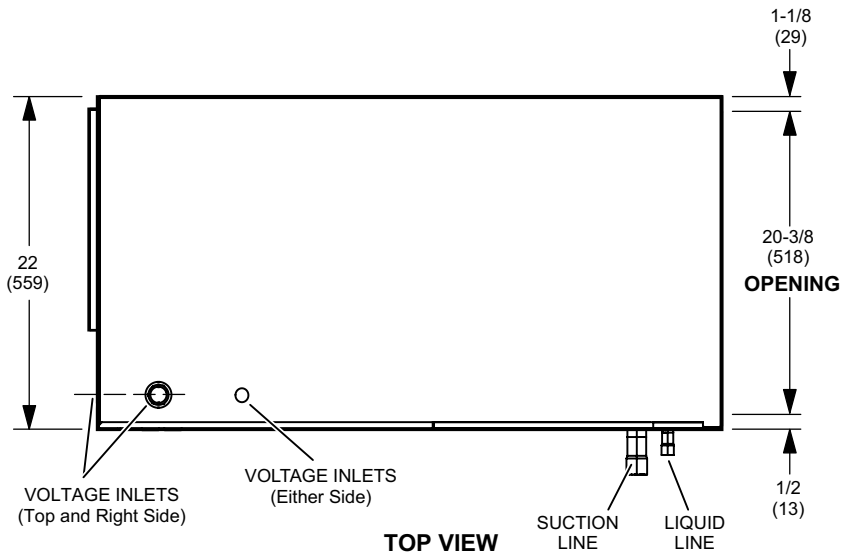
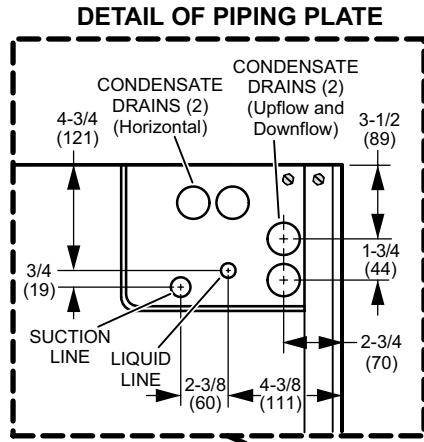

Dimensions	024		030		036 / 042		048		060	
	in.	mm	in.	mm	in.	mm	in.	mm	in.	mm
A	45-1/2	1156	47	1194	53-5/8	1362	55	1397	59-3/4	1518
B	18-1/2	470	18-1/2	470	21-1/2	546	21-1/2	546	21-1/2	546
C	16-1/2	419	16-1/2	419	19-1/2	495	19-1/2	495	19-1/2	495
D	16-1/4	413	16-1/4	413	19-1/4	489	19-1/4	489	19-1/4	489

All specifications and illustrations subject to change without notice and without incurring obligations.

DIMENSIONS (IN.) - ACCESSORIES

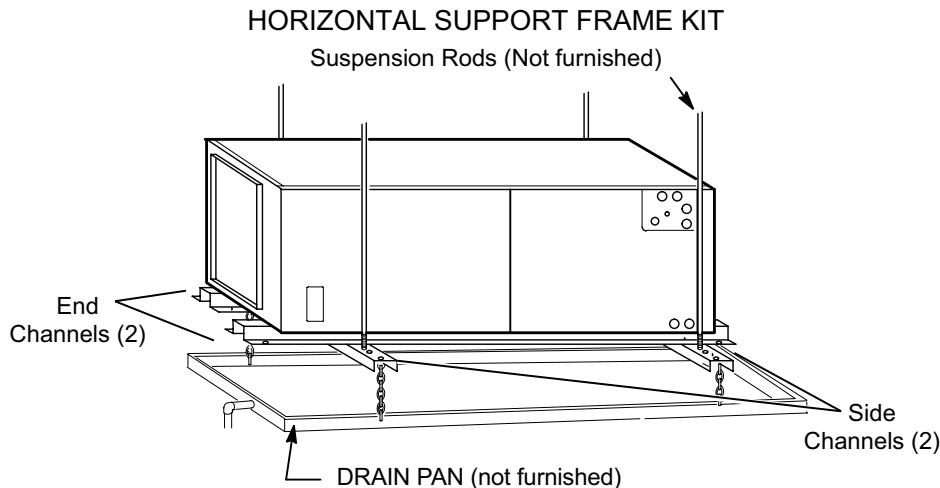

Includes (2) 1 x 1-1/2 x 32-5/8 in. side channels and (2) 1 x 3 x 53-7/8 in. end channels.

SIDE RETURN UNIT STAND (Upflow Only)

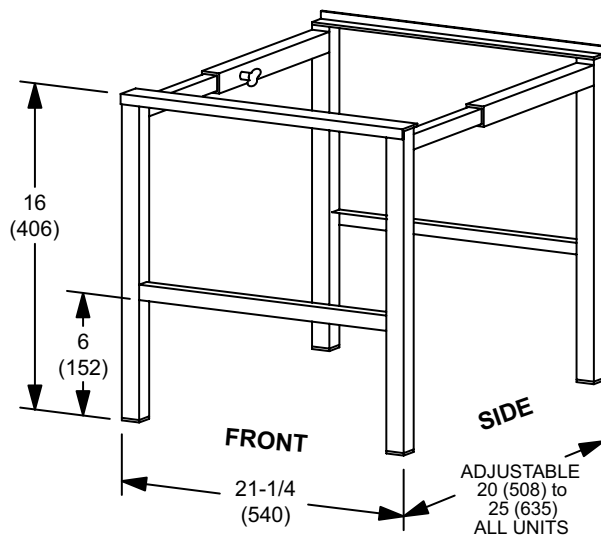

"This product complies with all California product labeling laws including, but not limited to, the Safe Drinking Water and Toxic Enforcement Act of 1986, more commonly known as Proposition 65."

Due to ongoing product improvements, specifications and dimensions are subject to change and correction without notice or incurring obligations. Determining the application and suitability for use of any product is the responsibility of the installer. Additionally, the installer is responsible for verifying dimensional data on the actual product prior to beginning any installation preparations.

Third party incentive and rebate programs have precise requirements as to product performance and certification. All products meet applicable regulations in effect on date of manufacture; however, certifications are not necessarily granted for the life of a product. Therefore, it is the responsibility of the applicant to determine whether a specific model qualifies for these incentive/rebate programs.