

Featured Highlights

- Outdoor Coil Fan
- High Capacity Liquid Line Drier
- High Pressure Switch
- Low Pressure Switch
- Scroll Compressor
- Heavy Gauge Steel Cabinet
- Refrigerant Line Connections and Access

Applications

- 1.5 through 5 tons
- Sound levels as low as 73 dBA
- Single-phase power supply
- Vertical air discharge
- Applicable to indoor air handlers or gas furnaces with indoor add-on coils
- Shipped completely factory assembled, piped and wired

Approvals

- AHRI Standard 210/240-2023 certified
- AHRI Certified system match-ups and expanded ratings, visit www.AHRIdirectory.org
- Sound rated to AHRI Standard 270-2008 test conditions
- Rated According to U.S. Department of Energy (DOE) test procedures
- Region specific models meet the minimum efficiency requirements for U.S. DOE Federal Regional Standards in that area
- Unit and components ETL, NEC and CEC bonded for grounding to meet safety standards for servicing
- ETL certified (U.S. and Canada)
- ISO 9001 Registered Manufacturing Quality System

For the latest AHRI system matches,
please visit AHRIdirectory.org

ASA13 SERIES

SPLIT SYSTEM AIR CONDITIONER

**Minimum Efficiency:
13.4 SEER2**



Warranty—5 years on parts, 10 years on compressor and heat exchanger
(Some limitations apply; see printed warranty for details.)
www.century-hvac.com



REFRIGERATION SYSTEM

R-454B Refrigerant

- Low GWP (Global Warming Potential)
- Zero ODP (Ozone Depletion Potential)
- Unit is factory pre-charged

Outdoor Coil Fan

- Direct drive fan
- Vertical air discharge
- Totally enclosed fan motor
- Sleeve bearings (018 through 048 and 060 models)
- Inherently protected
- Motor rain shield
- Louvered steel fan guard

Condenser Coil

- Proprietary coil design
- Enhanced aluminum alloy tube/enhanced fin coil
- Superior corrosion resistance
- Ripple-edged aluminum fins
- Aluminum tube construction
- Lanced fins for maximum fin surface exposure
- Fin collars grip tubing for maximum contact area
- Flared shoulder tubing connections
- Factory tested under high pressure
- Entire coil is accessible for cleaning

High Capacity Liquid Line Drier

- Furnished with unit for field installation
- Drier traps moisture or dirt that could contaminate the system
- 100% molecular-sieve, bead type, drier

High Pressure Switch

- Protects the system from high pressure conditions that can be a result of fan failure or a blocked/dirty coil
- Manual reset

Low Pressure Switch

- Shuts off unit if suction pressure falls below setting
- Provides loss of charge and freeze-up protection
- Automatic reset

Optional Accessories

Expansion Valve Kits

- Factory installed with R-454B on all indoor units
- Chatleff-style fitting

Freezestat

- Senses suction line temperature
- Cycles compressor off when suction line temperature falls below freezestat setpoint
- Opens at 29°F and closes at 58°F
- Installs on or near the discharge line of the evaporator or on the suction line

Loss of Charge Switch Kit

- Protects compressor from damage from low refrigerant charge conditions
- SPST, normally-closed
- Automatic reset

INDOOR REFRIGERANT DETECTION SYSTEM (RDS)

- Complies with UL 60335-2-40 approved standard
- Required for all systems using R-454B refrigerant
- Factory or field installed on all indoor units
- Consists of a RDS refrigerant detection sensor and an independent RDS control
- If refrigerant is detected the refrigerant detection system will prevent compressor and heating operation until refrigerant is no longer detected
- Refrigeration detection system also energizes the blower if refrigerant is detected to dissipate any concentrations of refrigerant from the space

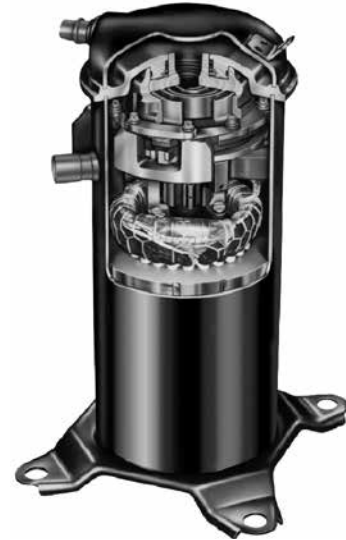

COMPRESSOR

Single-Stage Scroll Compressor

- High volumetric efficiency
- Uniform suction flow
- Constant discharge flow
- High efficiency
- Quiet operation
- Low gas pulses during compression reduces operational sound levels.
- Compressor motor is internally protected from excessive current and temperature
- Muffler in discharge line reduces operating sound levels
- Compressor is installed in the unit on resilient rubber mounts for vibration free operation

Scroll Compressor Operation

- Two involute spiral scrolls matched together generate a series of crescent-shaped gas pockets between them
- During compression, one scroll remains stationary while the other scroll orbits around it
- Gas is drawn into the outer pocket, the pocket is sealed as the scroll rotates
- As the spiral movement continues, gas pockets are pushed to the center of the scrolls. Volume between the pockets is simultaneously reduced
- When the pocket reaches the center, gas is now at high pressure and is forced out of a port located in the center of the fixed scrolls
- During compression, several pockets are compressed simultaneously resulting in a smooth continuous

- compression cycle
- Continuous flank contact, maintained by centrifugal force, minimizes gas leakage and maximizes efficiency
- Compressor is tolerant to the effects of slugging and contaminants. If this occurs, scrolls separate, allowing liquid or contaminants to be worked toward the center and discharged

Compressor Crankcase Heater (041, 042, 047, 048, 060 Models)

- Prevents migration of liquid refrigerant into compressor and ensures proper compressor lubrication

Optional Accessories

Compressor Crankcase Heater (018, 024, 030, 036, 042 Models)

- Prevents migration of liquid refrigerant into compressor and ensures proper compressor lubrication

Compressor Sound Cover

- Polymer outer shell
- 1/2 inch thick polyester fiber insulation
- All open edges are sealed with a one-inch wide hook and loop fastening tape

Compressor Hard Start Kit

- Single-phase units are equipped with a PSC compressor motor
- This type of motor normally does not need a potential relay and start capacitor
- For conditions such as low voltage, kit may be required to increase the compressor starting torque Compressor Low Ambient Cut-Off Switch
- Non-adjustable switch (low ambient cut-out)
- Prevents compressor operation when outdoor temperature is below 35°F

Compressor Time-Off Control

- Kit prevents compressor short-cycling
- Allows time for suction and discharge pressure to equalize
- Permits compressor start-up in an unloaded condition.
- Automatic reset with 5 minute delay between compressor shut-off and start-up

Indoor Blower Off Delay Relay

- Delays the indoor blower-off time during the cooling cycle

Low Ambient Kit

- Air conditioners can operate down to 45°F outdoor air temperature without additional controls
- Allows unit to operate properly down to 30°F

NOTE - Crankcase heater and freeze-stat should be installed on compressors equipped with a low ambient kit.

NOTE - A compressor lock-out thermostat should be added to terminate compressor operation below recommended operation conditions.

- Corner patch plate allows access to compressor components
- Drainage holes are provided in base section for moisture removal

Refrigerant Line Connections, Electrical Inlets, Service Valves

- Sweat connection suction and liquid lines
- Located on corner of unit cabinet
- Suction valve can be fully shut off, while liquid valve may be front seated to manage refrigerant charge while servicing system
- Refrigerant line connections and field wiring inlets are located in one central area of the cabinet
- See dimension drawing

Braze-Free/Press Fitting Flexibility

- Units can accommodate braze-free or press fittings for installation versatility.

CABINET

- Heavy gauge steel construction
- Louvered heavy gauge steel panels surround unit on all four sides
- Pre-painted cabinet finish
- Control box is conveniently located with all controls factory wired

MODEL NUMBER GUIDE

| | | | | | | | |
|--------------------|----------------------|----------|------------------|-------------------------|-----------------|---------------------------|-------------------|
| A | S | A | 13 | 36 | S | 1 | A |
| Air Conditioner | Residential Split | R-454B | Minimum SEER2 | Capacity BTUH x 1000 | Single Stage | Power 1 = 208/230-1-60 | Revision Level |

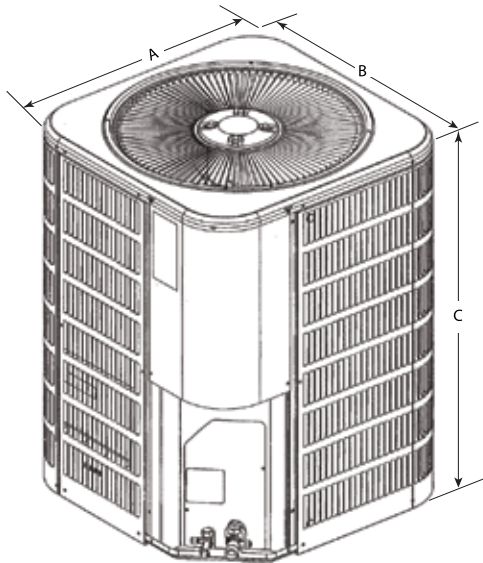
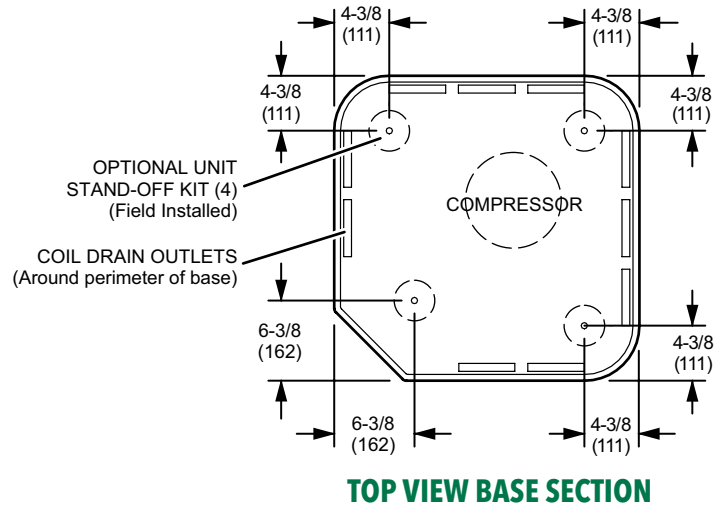
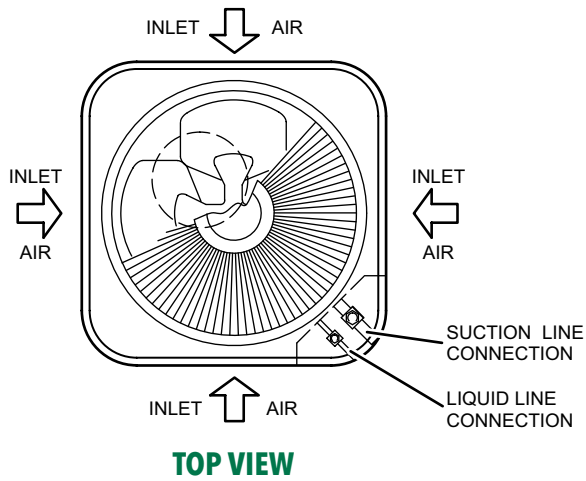

UNIT DIMENSIONS

| Model | Dimensions (inch) | | | Shipping Weight (Lbs.) |
|-----------|-------------------|-----------|------------|------------------------|
| | A - Width | B - Depth | C - Height | |
| ASA1318S1 | 26 | 26 | 25 | 128 |
| ASA1324S1 | 26 | 26 | 29 1/2 | 134 |
| ASA1330S1 | 30 | 30 | 29 1/2 | 152 |
| ASA1336S1 | 30 | 30 | 33 1/4 | 161 |
| ASA1342S1 | 30 | 30 | 37 1/2 | 195 |
| ASA1348S1 | 30 | 30 | 37 1/2 | 215 |
| ASA1360S1 | 30 | 30 | 37 1/4 | 250 |

Note: Dimensions listed are unit sizes w/o packaging

SOUND DATA

| Size | Octave Band Sound Power Levels dBA, re 10 ⁻¹² Watts Center Frequency - HZ | | | | | | | Sound Rating Number (dBA) | ² Estimated Sound Pressure Level at Distance From Unit (dBA at distance in ft.) | | | | |
|------|--|------|------|------|------|------|------|---------------------------|--|----|----|----|----|
| | 125 | 250 | 500 | 1000 | 2000 | 4000 | 8000 | | 3 | 5 | 10 | 15 | 50 |
| 018 | 53 | 58.5 | 66.5 | 69.5 | 65 | 62.5 | 54.5 | 73 | 66 | 61 | 55 | 52 | 41 |
| 024 | 56 | 66 | 72 | 71 | 67 | 63 | 56.5 | 76 | 69 | 64 | 58 | 55 | 44 |
| 030 | 55 | 64.5 | 70.5 | 72.5 | 67.5 | 61 | 54 | 76 | 69 | 64 | 58 | 55 | 44 |
| 036 | 58 | 67.5 | 71.5 | 70.5 | 66.5 | 61.5 | 55 | 76 | 69 | 64 | 58 | 55 | 44 |
| 042 | 56 | 65 | 71 | 71.5 | 67.5 | 62 | 55 | 76 | 69 | 64 | 58 | 55 | 44 |
| 048 | 61.5 | 68 | 73.5 | 72.5 | 69 | 64 | 56.5 | 78 | 71 | 66 | 60 | 57 | 46 |
| 060 | 63.5 | 70 | 75 | 75 | 70.5 | 68 | 61 | 80 | 73 | 68 | 62 | 59 | 48 |

NOTE - the octave sound power data does not include tonal correction.

1. Tested according to AHRI Standard 270-2008 test conditions.

2. Estimated sound pressure level at distance based on AHRI Standard 275-2010 method for equipment located on the ground, roof, or on side of building wall with no adjacent reflective surface within 9.8 feet. Sound pressure levels will increase based on changes to assumptions. For other applications, refer to AHRI Standard 275.

SPECIFICATIONS

| SIZE | ASA1318S1 | ASA1324S1 | ASA1330S1 | ASA1336S1 | ASA1342S1 | ASA1348S1 | ASA1360S1 |
|---|--|----------------|----------------|----------------|----------------|----------------|-------------------|
| Nominal Tonnage | 1.5 | 2 | 2.5 | 3 | 3.5 | 4 | 5 |
| Sound Rating Number | 73 | 76 | 76 | 78 | 76 | 78 | 80 |
| Connections (Sweat) | | | | | | | |
| Liquid line (OD) - in. | 3/8 | 3/8 | 3/8 | 3/8 | 3/8 | 3/8 | 3/8 |
| Suction line (OD) - in. | 3/4 | 3/4 | 3/4 | 3/4 | 3/4 | 7/8 | 1-1/8 |
| Compressor Type | 1-Stage Scroll | 1-Stage Scroll | 1-Stage Scroll | 1-Stage Scroll | 1-Stage Scroll | 1-Stage Scroll | 1-Stage Scroll |
| Refrigerant | ¹R-454B charge furnished | | | | | | |
| | 4 lbs. 0 oz. | 4 lbs. 7 oz. | 4 lbs. 14 oz. | 5 lbs. 10 oz. | 6 lbs. 2 oz. | 7 lbs. 10 oz. | 8 lbs. 8 oz. |
| Indoor Unit Expansion Valve (TXV) | 26Z70 | 26Z70 | 26Z70 | 26Z70 | 26Z71 | 26Z71 | 26Z72 |
| Outdoor Coil | | | | | | | |
| Net face area - ft. ² | 11.33 | 13.22 | 16.33 | 18.67 | 21.00 | 16.33 | 21.00 |
| Tube diameter - in. | 5/16 | 5/16 | 5/16 | 5/16 | 5/16 | 5/16 | 5/16 |
| Rows | 1 | 1 | 1 | 1 | 1 | 2 | 2 |
| Fins - in. | 26 | 26 | 26 | 26 | 26 | 22 | 22 |
| Outdoor Fan | | | | | | | |
| HP | 1/10 | 1/10 | 1/6 | 1/6 | 1/3 | 1/4 | 1/4 |
| Diameter - in. | 18 | 18 | 22 | 22 | 22 | 22 | 22 |
| Blades | 3 | 3 | 3 | 3 | 3 | 3 | 3 |
| Cfm | 2290 | 2350 | 2610 | 2800 | 2985 | 2875 | 3250 |
| Rpm | 1075 | 1075 | 825 | 825 | 825 | 825 | 845 |
| Watts | 150 | 155 | 160 | 190 | 150 | 160 | 280 |
| Shipping Data - lbs. | 128 | 134 | 152 | 161 | 195 | 215 | 250 |
| ELECTRICAL DATA | | | | | | | |
| Line voltage data (Volts-Phase-Hz) | 208/230-1-60 | 208/230-1-60 | 208/230-1-60 | 208/230-1-60 | 208/230-1-60 | 208/230-1-60 | 208/230-1-60 |
| ² Maximum overcurrent protection (MOCP) amps | 15 | 20 | 25 | 30 | 35 | 40 | 50 |
| ³ Minimum circuit ampacity (MCA) | 11.1 | 13.5 | 16.6 | 17.8 | 21.2 | 24.3 | 31.3 |
| Compressor | | | | | | | |
| Rated load amps | 8.3 | 10.2 | 12.5 | 13.4 | 14.9 | 18.0 | 23.7 |
| Locked rotor amps | 45 | 60.2 | 67.8 | 82.5 | 109 | 126 | 157 |
| Fan Motor | | | | | | | |
| Full load amps | 0.65 | 0.65 | 1.0 | 1.0 | 2.6 | 1.7 | 1.7 |
| Locked rotor amps | 1.3 | 1.3 | 1.9 | 1.9 | --- | 3.2 | 3.2 |
| OPTIONAL ACCESSORIES - ORDER SEPARATELY | | | | | | | |
| Compressor Hard Start Kit | Copeland 27V63 | • | • | • | • | • | Factory Installed |
| Crankcase Heater | LG 27U16 | • | • | • | • | • | Factory Installed |
| Compressor Hard Start Kit | Copeland 27V63 | • | | | | • | • |
| | LG 27U16 | | • | • | • | • | • |
| | LG 10J42 | • | • | • | • | • | • |
| Compressor Low Ambient Cut-Off Switch | 45F08 | • | • | • | • | | |
| Compressor Timed-Off Control | 47J27 | • | • | • | • | • | • |
| Compressor Sound Cover | 18J42 | • | • | • | • | • | • |
| Freezestat | 93G35 | • | • | • | • | • | • |
| Indoor Blower Off Delay Relay | 58M81 | • | • | • | • | • | • |
| Loss of Charge Switch Kit | 84M23 | • | • | • | • | • | • |
| 4 Low Ambient Kit (Fan Cycling) | 34M72 | • | • | • | • | • | • |

NOTE - Extremes of operating range are plus 10% and minus 5% of line voltage.

1. Refrigerant charge is sufficient for 15 ft. length of refrigerant lines. For longer line set requirements see the Installation Instructions for information about line set length and additional refrigerant charge required.
2. HACR type breaker or fuse.
3. Refer to National or Canadian Electrical Code manual to determine wire, fuse and disconnect size requirements.
4. Crankcase Heater and Freezestat are recommended with Low Ambient Kit.

FIELD WIRING

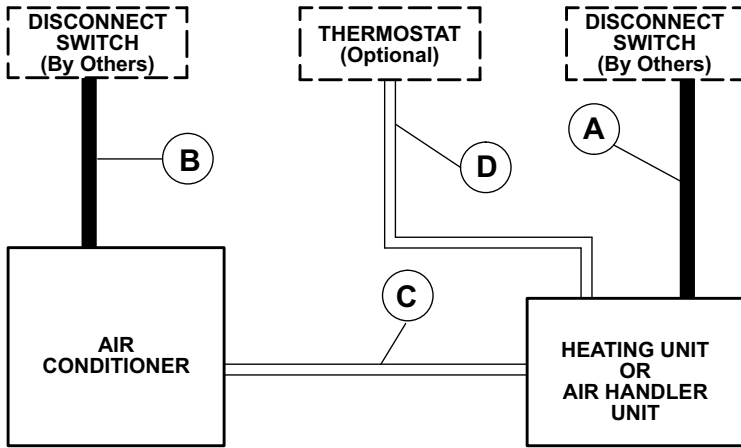

- A - Two Wire Power (not furnished). See Indoor Unit Electrical Data
B - Two Wire Power (not furnished). See Electrical Data
C - Four Wire Low Voltage (not furnished). 18 ga. minimum
D - Five Wire Low Voltage (not furnished). 18 ga. minimum

All wiring must conform to NEC or CEC and local electrical codes.

INSTALLATION CLEARANCES

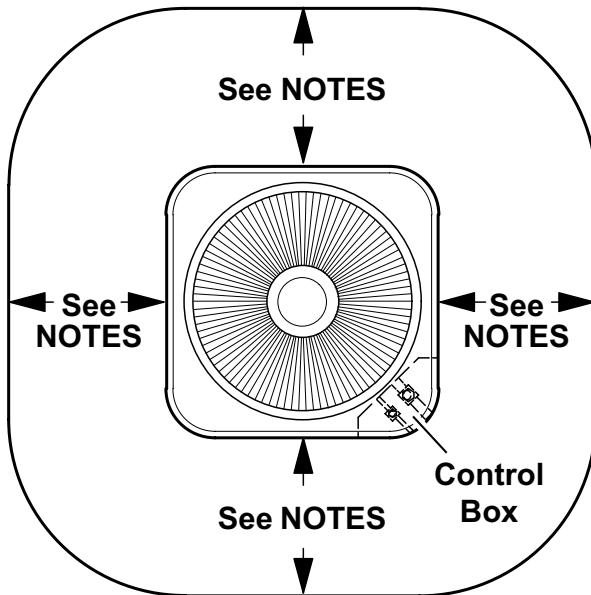

NOTES:

- Service Clearance – 30 in. (762 mm) must be maintained on one of the sides adjacent to the control box
- Clearance to one of other three sides must be 36 in. (914 mm).
- Clearance to one of the remaining two sides may be 12 in. (305 mm) and the final side may be 6 in. (152 mm).
- A clearance of 24 in. must be maintained between two

TXV SUBSTITUTION - R-454B

A general guide for replacing the factory installed R-454B TXV if the indoor unit (coil/air handler) is larger or smaller than the outdoor unit.

| Outdoor Unit | | Indoor Unit | | TXV Furnished | TXV Replacement |
|--------------|------|-------------|-------|------------------|--------------------|
| Size | Tons | Size | Tons | | |
| 018 | 1.5 | 42 | 3.5 | 26Z70 | 26Z71 |
| 018 | 1.5 | 48 | 4 | 26Z70 | 26Z71 |
| 018 | 1.5 | 49 | 4 | 26Z70 | 26Z71 |
| 018 | 1.5 | 50/60 | 4/5 | 26Z70 | 26Z72 |
| 018 | 1.5 | 51/61 | 4/5 | 26Z70 | 26Z72 |
| 018 | 1.5 | 60 | 5 | 26Z70 | 26Z72 |
| 024 | 2 | 42 | 3.5 | 26Z70 | 26Z71 |
| 024 | 2 | 48 | 4 | 26Z70 | 26Z71 |
| 024 | 2 | 49 | 4 | 26Z70 | 26Z71 |
| 024 | 2 | 50/60 | 5 | 26Z70 | 26Z72 |
| 024 | 2 | 51/61 | 5 | 26Z70 | 26Z72 |
| 024 | 2 | 60 | 5 | 26Z70 | 26Z72 |
| 030 | 2.5 | 42 | 3.5 | 26Z70 | 26Z71 |
| 030 | 2.5 | 48 | 4 | 26Z70 | 26Z71 |
| 030 | 2.5 | 49 | 4 | 26Z70 | 26Z71 |
| 030 | 2.5 | 50/60 | 4/5 | 26Z70 | 26Z72 |
| 030 | 2 | 51/61 | 4/5 | 26Z70 | 26Z72 |
| 030 | 2.5 | 60 | 5 | 26Z70 | 26Z72 |
| 036 | 3 | 42 | 3.5 | 26Z70 | 26Z71 |
| 036 | 3 | 48 | 4 | 26Z70 | 26Z71 |
| 036 | 3 | 49 | 4 | 26Z70 | 26Z71 |
| 036 | 3 | 50/60 | 5 | 26Z70 | 26Z72 |
| 036 | 3 | 51/61 | 5 | 26Z70 | 26Z72 |
| 036 | 3 | 60 | 5 | 26Z70 | 26Z72 |
| 042 | 3.5 | 24 | 2 | 26Z71 | 26Z70 |
| 042 | 3.5 | 30 | 2.5 | 26Z71 | 26Z70 |
| 042 | 3.5 | 30/36 | 3 | 26Z71 | 26Z70 |
| 042 | 3.5 | 36 | 3 | 26Z71 | 26Z70 |
| 048 | 4 | 30/36 | 2.5/3 | 26Z71 | 26Z70 |
| 048 | 4 | 36 | 3 | 26Z71 | 26Z70 |

TXV RANGES:

26Z70 - 1.5 to 3 ton systems - Use on 3 ton (036) and lower systems.

26Z71 - 3.5-4 ton systems - Use down to 3.5 ton (042) systems.

26Z72 - 5 ton systems - Use on 5 ton (060) systems only.



"This product complies with all California product labeling laws including, but not limited to, the Safe Drinking Water and Toxic Enforcement Act of 1986, more commonly known as Proposition 65."

Due to ongoing product improvements, specifications and dimensions are subject to change and correction without notice or incurring obligations. Determining the application and suitability for use of any product is the responsibility of the installer. Additionally, the installer is responsible for verifying dimensional data on the actual product prior to beginning any installation preparations.

Third party incentive and rebate programs have precise requirements as to product performance and certification. All products meet applicable regulations in effect on date of manufacture; however, certifications are not necessarily granted for the life of a product. Therefore, it is the responsibility of the applicant to determine whether a specific model qualifies for these incentive/rebate programs.