

SPECIFICATIONS

- High efficiency lanced fin design
- R-32, R454B, AC & Heat Pump compatible with Refrigerant Detection System
- All coils have durable packaging with bar coded labels on the box.
- Threaded expansion valves available factory installed or as a field installed kit
- Factory installed Refrigerant Detection Sensor Bracket
- Coils are air pressure tested at 500 psi, leak tested with helium, sealed with rubber plugs, then charged with dry air
- Downflow drip shields are molded into drain pan
- Down-turned headers are sized out to easily receive line set
- Includes die-cut foam sheet for sealing, drain ELL, drain hose & clamp
- Dedicated upflow/downflow
- Copper refrigerant connections for easy brazing
- Rifled copper tubing

R-32 Pistons		R-454B Pistons	
MBTUH	Size	MBTUH	Size
18	41	18	46
24	46	24	53
30	53	30	59
36	57	36	65
42	62	42	70
48	65	48	76
60	76	60	84

Line-Set Connection Size

1-1/2 - 3 Ton 3/8" x 3/4"
 3-1/2 - 5 Ton 3/8" x 7/8"

CMH SERIES

MANUFACTURED HOUSING COILS



Representative drawing only.
 Some models may vary in appearance.



www.comfort-aire.com • www.century-hvac.com



MODEL NUMBER GUIDE

C	MH	18	P	M	1	M	L
Coil Type C = Uncased Vertical		Refrigerant Detection System R = RDS Controller & Sensor (Factory Installed) L = Leak Detection Sensor (Factory installed) S = R410A Service Coil (Replacement only)					
Application MH = Mobile Home		Series					
Nominal Tonnage BTUH 18 = 1.5 ton 1824 = 1.5 - 2 ton 24 = 2 ton 2430 = 2 - 2.5 ton 30 = 2.5 ton 3036 = 2.5 - 3 ton 36 = 3 ton 42 = 3.5 ton 4248 = 3.5 - 4 ton 48 = 4 ton 4860 = 4 - 5 ton 60 = 5 ton		Coil Code					
		Width M = 18"					
		Refrigerant Type & Metering Device P = Piston (R-454B) A = R-454B Non-bleed HP-A/C TXV B = R-32 Non-bleed HP-A/C TXV T = R-410A Non-bleed HP-AC TXV					

Please Note:

The R Series coils include RDS mitigation board and sensor. Recommended for use with non-LE Series indoor units.

The L Series coils include the RDS sensor only and are intended for use with LE Series indoor units.

The S Series coils are R410A replacement coils only and many not be used for new installations or be eligible for new ratings. (Equipped with 410A piston).

If an L Series coil is used with a non-A2L compliant furnace OR a non-LE Series furnace, a mitigation board (p/n 27A05) will need to be installed in the furnace.

Coil Model	R454B Installed Piston Size	Dimensions		
		Pan Width (W)	Pan Depth (D)	Coil Height (H)
CMH18/24PM3M	53	18"	19-1/2"	17"
CMH18/36PM1M	65	18"	19-1/2"	17"
CMH24/30PM1M	59	18"	19-1/2"	19"
CMH36PM2M	65	18"	19-1/2"	19"
CMH36PM3M	65	18"	19-1/2"	15"
CMH42/48PM1M	76	18"	19-1/2"	19"
CMH42/48PM2M	76	18"	19-1/2"	19"
CMH42/60PM3M	84	18"	19-1/2"	19"
CMH48/60PM1M	84	18"	19-1/2"	25"
CMH48/60PM2M	84	18"	19-1/2"	23"
CMH48PM2M	76	18"	19-1/2"	21"
CMH18/24AM3M	53	18"	19-1/2"	11"
CMH18/36AM1M	65	18"	19-1/2"	17"
CMH24/30AM1M	59	18"	19-1/2"	19"
CMH36AM2M	65	18"	19-1/2"	19"
CMH36AM3M	65	18"	19-1/2"	15"
CMH42/48AM1M	76	18"	19-1/2"	19"
CMH42/48AM2M	76	18"	19-1/2"	19"
CMH42/60AM3M	84	18"	19-1/2"	19"
CMH48/60AM1M	84	18"	19-1/2"	25"
CMH48/60AM2M	84	18"	19-1/2"	23"
CMH48AM2M	76	18"	19-1/2"	21"

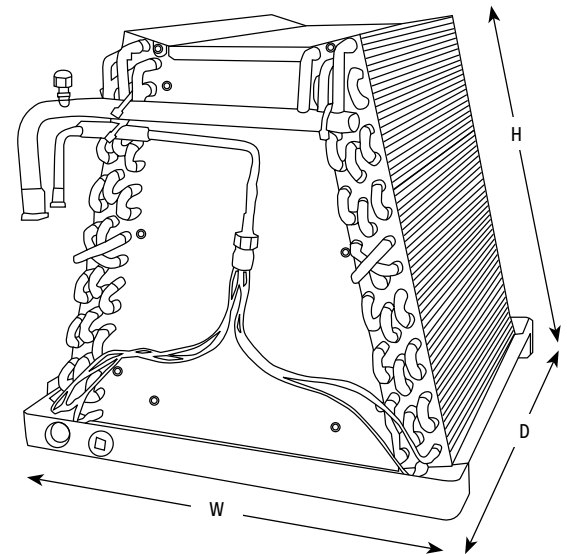

"This product complies with all California product labeling laws including, but not limited to, the Safe Drinking Water and Toxic Enforcement Act of 1986, more commonly known as Proposition 65."

Due to ongoing product improvements, specifications and dimensions are subject to change and correction without notice or incurring obligations. Determining the application and suitability for use of any product is the responsibility of the installer. Additionally, the installer is responsible for verifying dimensional data on the actual product prior to beginning any installation preparations. Third party incentive and rebate programs have precise requirements as to product performance and certification. All products meet applicable regulations in effect on date of manufacture; however, certifications are not necessarily granted for the life of a product. Therefore, it is the responsibility of the applicant to determine whether a specific model qualifies for these incentive/rebate programs.