Comfort-Aire®

Century®

**INSTALLATION , OPERATION &
MAINTENANCE MANUAL**

**Horizontal/Side Discharge
Condensing Units**

Models

CMA12SD-0

CMA18SD-1

CMA24SD-1

CMA30SD-1

CMA36SD-1

CMA48SD-1

Horizontal/Side Discharge Condensing Units: Installation, Operation and Maintenance

TABLE OF CONTENTS

Safety Precautions 3

General Operating Instructions..... 4

General Product Information 5

Outdoor Unit Installation 6-7

Unit Wiring 8

Wiring Diagrams 9-12

Refrigerant Piping..... 13

Leak Test, Evacuation & Release of Refrigerant..... 13

Initial Start-Up & Checks 14



Field Charging 14

Final Inspection 14

SAFETY PRECAUTIONS

- Please read this installation manual completely before installing the product.
- If the power cord is damaged, replacement work shall be performed by authorized personnel only.
- Installation work must be performed in accordance with all local and national codes by authorized personnel only.
- Contact an authorized service technician for repair, maintenance or installation of this unit.
- All the pictures in the instructions are for explanation purposes only, and may differ from the actual product you purchased.
- The design and specifications are subject to change without prior notice for product improvement. Consult with the sales agency or manufacturer for details.

■ The seriousness of safety precautions is classified by the following indications:

	WARNING	This symbol indicates the possibility of death or serious injury.
	CAUTION	This symbol indicates the possibility of injury or damage to property.

WARNING

- 1) Install according to these installation instructions strictly. If installation is defective, it will cause water leakage, electrical shock fire, and may void the warranty.
- 2) Use the manufacturer's specified and supplied parts only.
- 3) Install in a strong and firm location which is able to withstand the unit's weight. If the strength is insufficient or installation is not properly done, the units can fall and cause injury.
- 4) For electrical work, follow all local and National electrical codes and these installation instructions. An independent circuit and single outlet must be used. If electrical circuit capacity is not enough or a defect found in electrical work, it may cause electrical shock or fire.
- 5) Use the specified cable, connect tightly and clamp the cable so that no external force will be applied to the terminal. If connection is loose, it may cause excessive heat build up.
- 6) Wire routing must be properly arranged so that control board cover is fixed properly. If control board cover is not fixed perfectly, it will cause heat build up at connection point of terminal, fire or electrical shock.
- 7) When carrying out piping connections, take care not to let air substances other than the specified refrigerant go into refrigeration circuit. Otherwise, it will cause lower capacity, abnormal high pressure in the refrigeration cycle, explosion and injury.

CAUTION

- 1) This equipment must be properly grounded and installed with a ground leakage circuit breaker, otherwise it may cause electrical shock.
- 2) Do not install this unit in places where leakage of flammable gas may occur. If gas leaks and accumulates near the unit, it may cause fire.
- 3) Carry out drainage piping as mentioned in installation instructions. If drainage is not properly done, water may enter the room and damage furniture.

OPERATING INSTRUCTIONS

Air conditioners are designed to provide comfort cooling at outside temperatures above 65°F (18°C) but less than 109°F (43°C). Operating the air conditioner outside of this temperature range may cause unit failure and will void the warranty. If you have need for cooling at lower outdoor temperatures a "low ambient cooling kit" can be field installed. Contact your local contractor or call the factory.

TO OPERATE:

NOTE: *The thermostat operation may vary by type and model used. Please consult the operating manual that was provided with the thermostat. The instructions below are generalized for most standard thermostat models.*

1. Set the switch on your wall thermostat to the 'cool' position.
2. Set the desired temperature (between 63-86°F or 17-30°C) you want to maintain by moving the temperature setting on your thermostat. If the room is warmer than the setting, the unit will turn on and begin to blow cool air after a few minutes. A warm, humid room or building may take several hours of continuous operation to cool to the thermostat set point the first time. Once the set temperature is reached the unit will cycle on and off.
3. Set the 'Fan' switch on the thermostat to 'auto' if you want the fan to run only when cooling is needed, or to 'on' if you want continuous air circulation. The 'on' setting of the fan generally provides better temperature control by eliminating stagnant air.

NOTE: *A properly installed and sized unit will not cycle more than 10 times per hour. If you notice more frequent starts call your service contractor.*

4. For energy conservation reasons, you may want to set your thermostat at a higher temperature when you are away. Do not raise the temperature setting by more than 5 degrees. Changing the temperature by more than 5 degrees or shutting the unit 'off' can actually cost more than leaving the setting at a constant temperature.

IMPORTANT

Wait at least 3 minutes after turning your air conditioner off before trying to restart it. This gives the unit the time needed to stabilize before restarting. Failure to do so may cause unit damage and failure.

MAINTENANCE:

Only simple periodic maintenance is required

1. Change or clean the indoor unit air filter monthly or more frequently if unusual conditions are encountered. If you have a disposable type, throw the old one away and install a fresh one of the same size and type. If your unit has a washable type then vacuum and wash with soap and water. Flush thoroughly and dry before re-installing.
2. Keep the coil in the outdoor unit clean. Periodically flush the coil thoroughly with a garden hose. Clean away all foreign materials such as dust, leaves, grass clippings, papers, etc.

WARNING

Turn the power off first! Serious injury or death may result if water spray is directed at live electrical connections or power sources.

IMPORTANT!

Alterations and replacement parts:

Altering the product or replacing parts with non-authorized parts will void the factory Warranty and may result in adverse operational performance and/or a possible hazardous safety condition to service personnel and occupants. If you are in doubt as to how to service this unit or where to find factory replacement parts, call Heat Controller at (517) 787-2100 for assistance.

GENERAL PRODUCT INFORMATION

UNPACKING AND INSPECTION:

The condensing unit is shipped completely assembled and in its own package. All goods are inspected at the factory and released to the freight company in good condition. When received at the site, a visual inspection of all packages should be made immediately. Any evidence of rough handling or apparent damage should be noted on the delivery receipt and the material inspected in the presence of the carrier's representative. If damaged a claim should be immediately filed with the freight company.

COOLING OPERATION

TEMPERATURE LIMITS:

Heat Controller Condensing units are designed to operate in cooling at outside temperatures between 65°F (18°C) and 109°F (43°C). If the condensing unit will be used to cool at temperatures below 65°F (18°C), a low ambient control must be field installed. Operation below 65°F (18°C) without low ambient control will void the warranty.

INDOOR UNIT USE

AND SYSTEM EFFICIENCY:

Heat Controller condensing units are designed to be compatible with most major brands of domestic evaporator coils/air handlers. Imported ductless air handlers maybe used but often do not include an expansion device. Appropriately-sized piston or similar metering devices are acceptable for use, but bleed-style thermostatic expansion valves should be used where specific AHRI-Match ratings

THERMOSTAT AND INDOOR

FAN TIME DELAY:

All indoor units should include a fan time delay. This may be accomplished by using a digital wall thermostat or installation of a different fan time delay designed to work with your specific furnace/air handler. As follows:

MODEL	12	18	24	30	36	48
DELAY	115s	90s	90s	90s	100s	65s

Most brands of electronic thermostats include a fan delay. Properly specified thermostats are the responsibility of the installer. Proper temperature control and unit operation depends on proper thermostat selection and location. Refer to the thermostat manufacturer's installation instructions for specified recommendations. Good practice is to avoid outside walls, locations where the sun may shine directly on the thermostat, and locations where the air from supply registers or unit outlets blow on the thermostat. Also avoid locations where the thermostat could be jarred by a closing door or high traffic area.

WARNING: An in-line filter drier is required when the unit is installed. The filter drier is not provided by the factory, therefore a locally purchased filter drier must be used to remove any particulates or moisture that may be present in the system. Installations without an in-line filter drier may void the warranty.

OUTDOOR UNIT INSTALLATION

UNIT LOCATION AND MOUNTING:

Choose a location that places the condensing unit as close to the indoor unit as possible. The maximum unit separation and vertical lift (compressor above evaporator) must be taken into account [See Fig 1]. Do not exceed allowable pipe lengths.

Fig. 1

Refrigerant Piping		Model No.				
		CMA12SD-0	CMA18SD-1	CMA24SD-1	CMA30SD-1	CMA36SD-1
Liquid-Gas	In.	1/4 - 1/2		3/8 - 5/8	3/8 - 3/4	
Max. Refrigerant Line Length*	Ft.	82			98	
Max. Elevation Vertical Lift**	Ft.	33			49	

*Minimum pipe length must not be less than 15 feet.

** "P" trap risers every 10 ft. when outdoor unit is installed above indoor unit.

NOTE: Oil traps must be installed every 10ft. when the outdoor unit is installed above the indoor unit.

Install the outdoor unit on a rigid surface, able to withstand the unit's weight, such as a concrete slab.

If the installation location allows the unit to be exposed to strong winds (such as sea side applications), ensure that the unit has a barrier from the wind [See Fig. 2]. This will assist with the proper operation of the fan by obstructing strong gusts of wind from entering the unit's cabinet.

Fig. 2

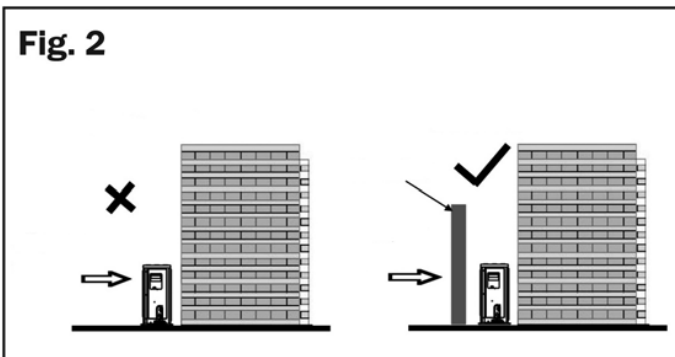

Avoid areas where water, snow, or ice may fall from a roof onto the unit. In climates where snow is a consideration, locate the unit away from areas prone to drifting. Ensure the location of the unit will not be subject to snow drifts, heavy accumulation of snow or leaves or other seasonal debris. If unavoidable, provide an awning for the unit.

An awning can be built over the outdoor unit to prevent direct sunlight or rain exposure or snowfall. Ensure that the awning is at least 2 ft. above the top of the unit's housing.

During heating and defrost modes, the condensate should be properly drained away from the unit.

Insure free flow of air into and out of the unit. Inlets/outlets should stay clear of obstructions such as walls and shrubs. Minimum clearances must be adhered to [See Fig. 4 & 5 on page 7].

Do not locate two or more units in a way that will block air flow or in a way that hot air from one unit will blow into a nearby unit [See Fig. 3].

Fig. 3

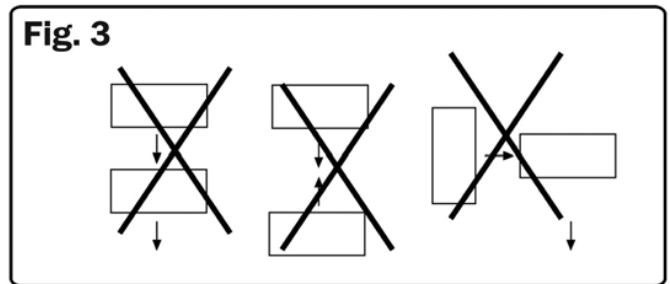

OUTDOOR UNIT INSTALLATION continued

Clearances

1. Ensure that there is sufficient clearance around the unit for installation and maintenance. Clearance must be maintained to ensure that the air inlets and outlets are not obstructed.

[See Fig. 4].

Anchor the outdoor unit with a 10mm (3/8 inch) diameter bolt and nut tightly on a concrete or rigid surface [See Fig. 5]. Anchoring is especially recommended in seaside/high wind applications and/or areas prone to earthquakes.

1. Split type outdoor unit clearances

Fig. 4

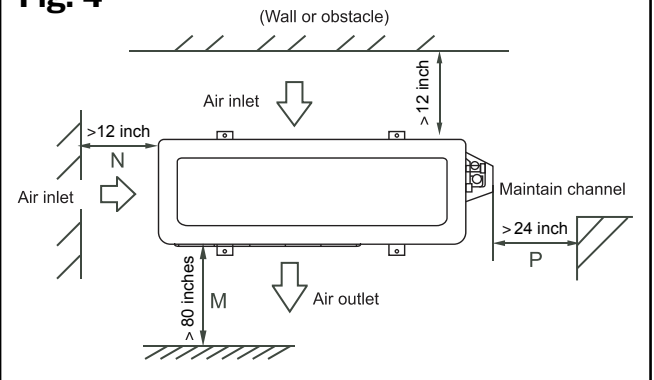

1. Split type outdoor unit dimensions

Fig. 5

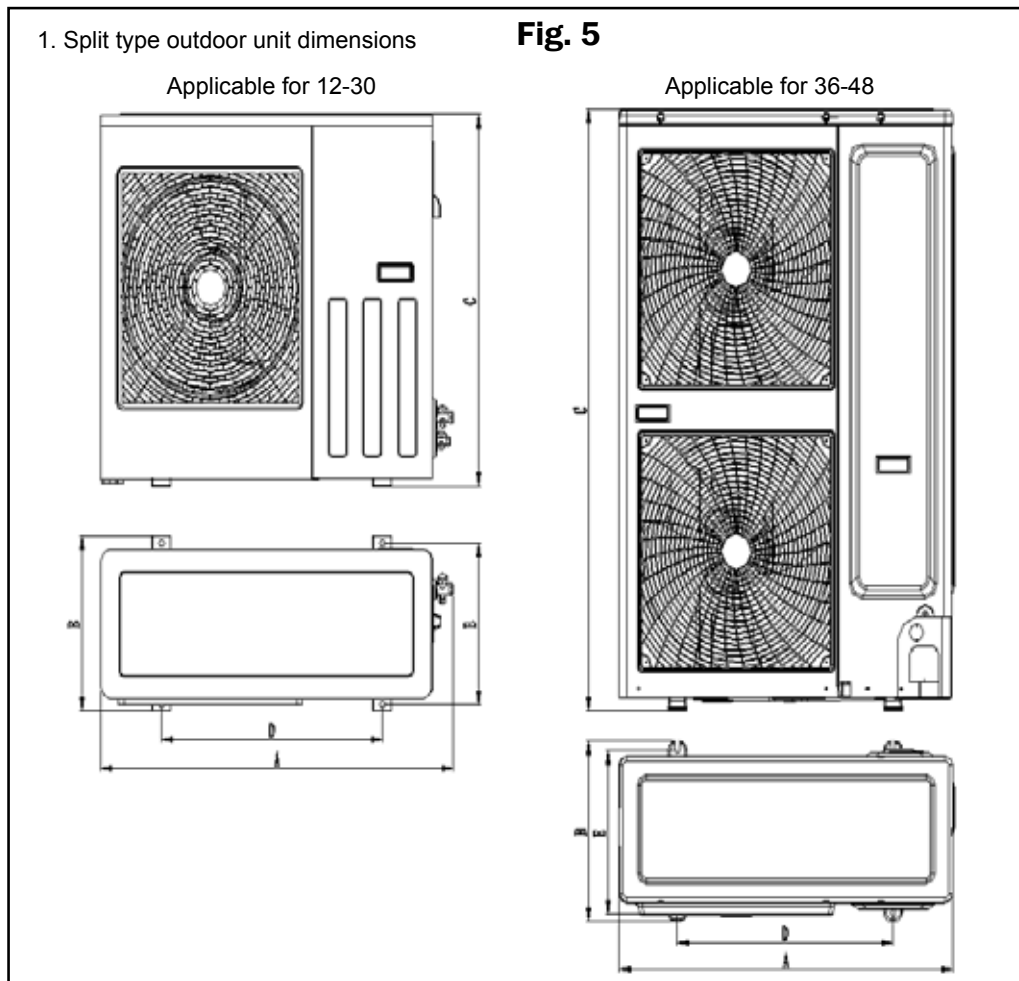

MODEL	A	B	C	D	E
12	32.0	12.0	21.1	20.1	10.9
18	36.4	14.4	27.6	23.2	13.4
24	41.1	17.0	31.1	27.8	15.5
30	41.3	15.7	39.2	27.6	15.0
36&48	35.9	15.7	52.4	23.0	14.2

Units in inches

UNIT WIRING

ELECTRICAL WIRING AND SUPPLY VOLTAGE:

All electrical wiring must be done according to NEC and local codes. Nameplate data indicates the operating voltage, phase, ampacity, maximum over current protection, and minimum voltage.

The contractor is to provide an individual branch circuit for over current protection for the unit as required by code. Run power supply wiring through a weatherproof disconnect box and conduit to the unit connection. Disconnects are required to be within sight and easy reach of the unit (usually within 3 feet).

Check the unit wiring diagram for the number of conductors required. Route neatly and protect from sharp edges and damage.

Inadequate wiring and/or improper electrical supply will likely result in failure of the compressor and other electrical components and voids the warranty.

NOTE: The supply voltage must be consistent with the rated voltage of the air conditioner, not to exceed +/- 10%. Ensure the unit is properly grounded.

Outdoor unit wiring connection

1. Remove the electrical control cover from the outdoor unit.
2. Connect the cables to the terminals as identified with their respective designated terminal spaces on the terminal block of indoor and outdoor units. 600V THHN 14 AWG/4 conductor unshielded stranded copper cable is recommended, however NEC/local codes prevail.
3. To prevent the entrance of water into outdoor unit, form a loop in the cable [See Fig. 6].
4. Insulate any unused conductors with PCV/ Electrical tape, so that they do not touch any other exposed electrical or metal parts.

CAUTION

Incorrect wiring connections may cause electrical parts to malfunction. All wiring must comply with local and national electrical codes and be installed by qualified and skilled electricians.

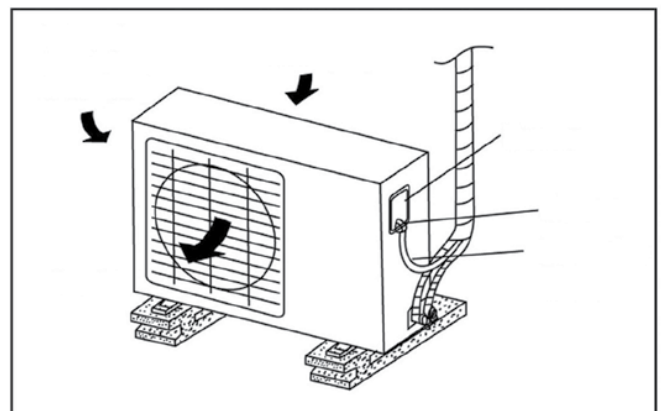

MODEL		12	18	24	30	36	48
POWER (outdoor)	PHASE	1Phase	1Phase	1Phase	1Phase	1Phase	1Phase
	VOLT	115V	208/230V	208/230V	208/230V	208/230V	208/230V
CIRCUIT BREAKER/FUSE (A)		15	10	15	20	25	30
MINIMUM CIRCUIT AMPACITY (A)		10	9	10.5	14	17	23

OUTDOOR UNIT WIRING CONNECTION continued

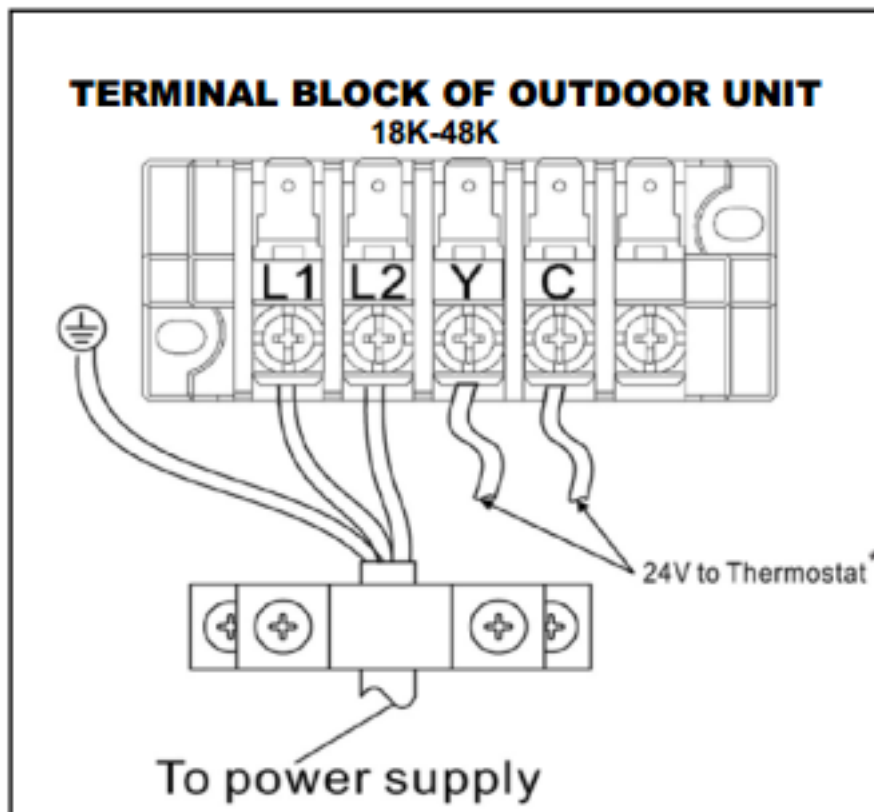
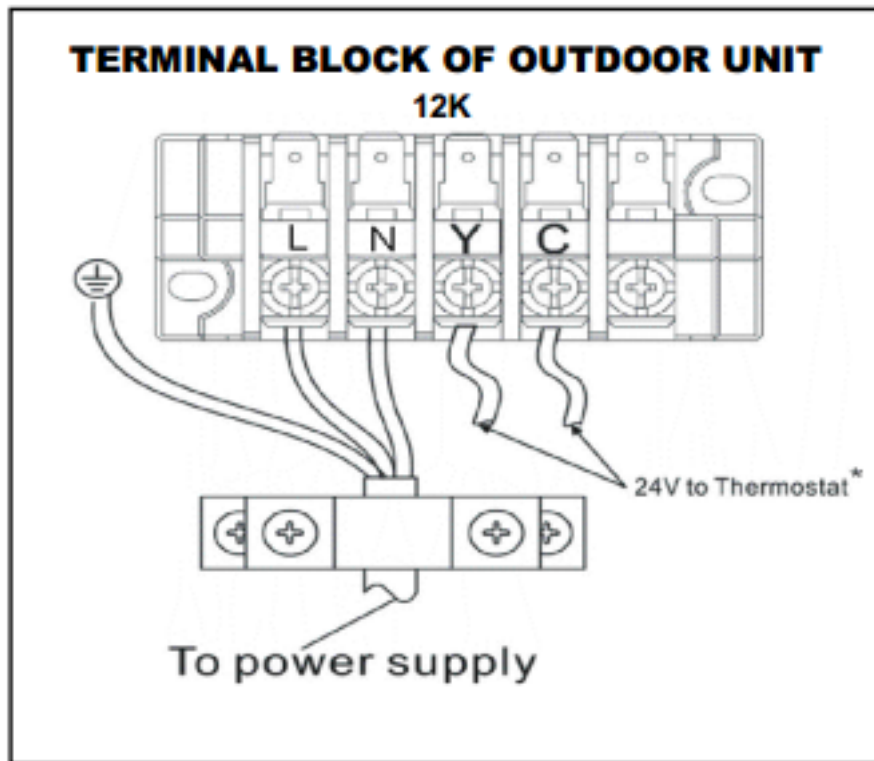

***NOTE:** Please refer to the installation instructions of the 24V thermostat used in conjunction with this unit for additional wiring instructions.

OUTDOOR UNIT WIRING CONNECTION continued

12K

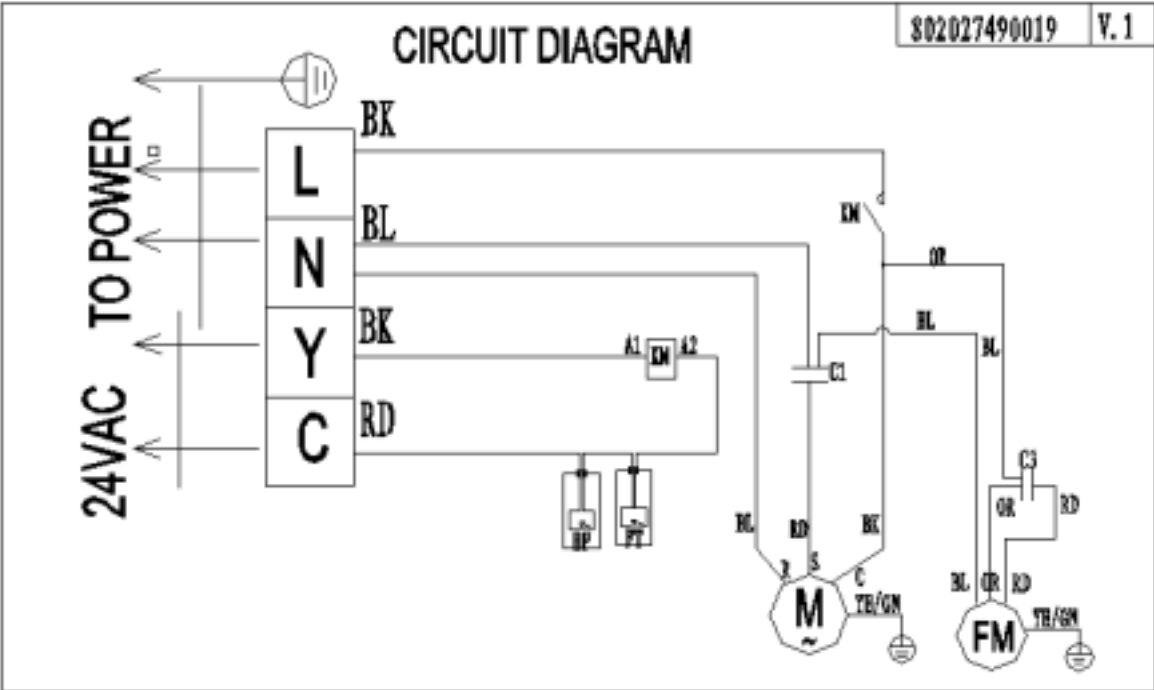

18K

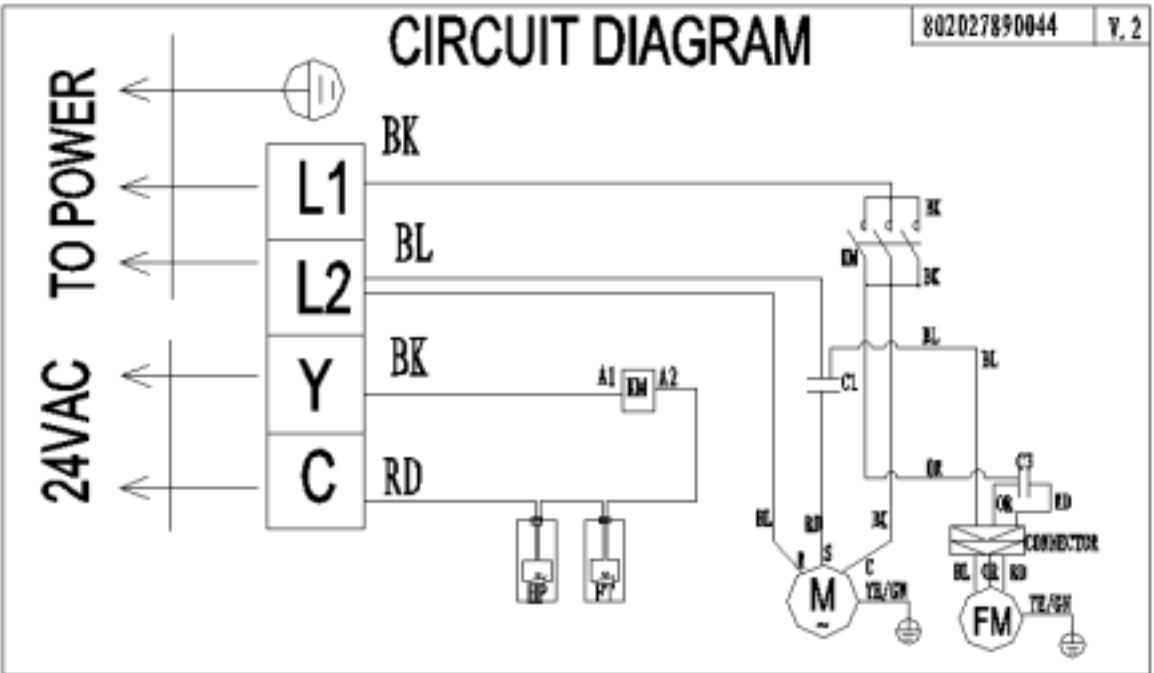

*NOTE: For reference only, the actual wiring diagram shall prevail

OUTDOOR UNIT WIRING CONNECTION continued

24K & 30K

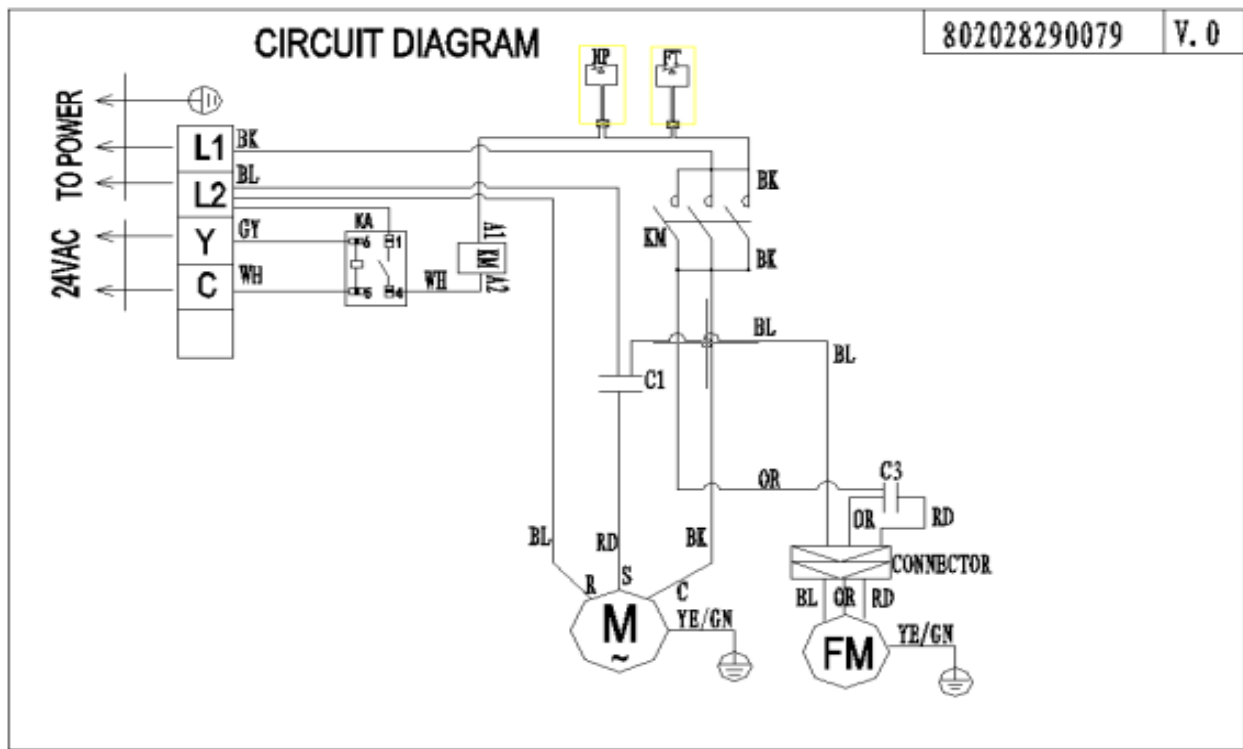

36K

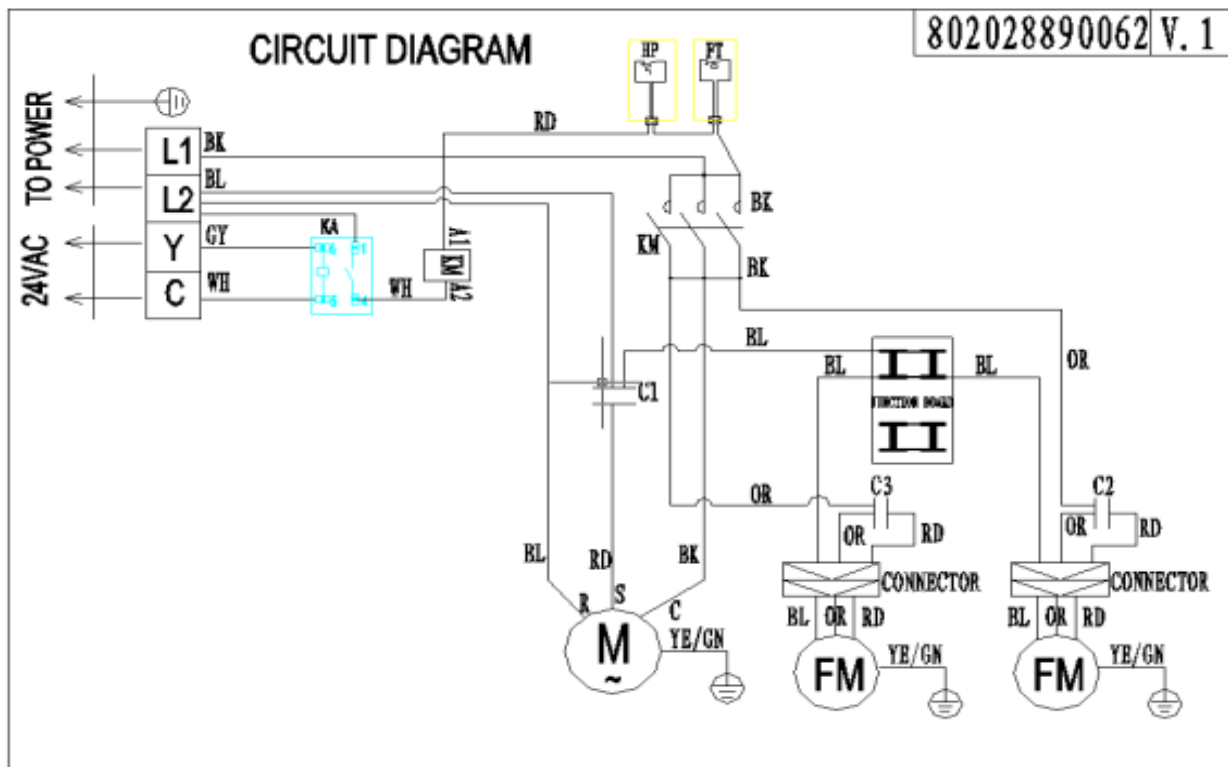

***NOTE:** For reference only, the actual wiring diagram shall prevail

REFRIGERANT PIPING

The length of refrigerant lines and the number of bends determine the pressure drop which affects capacity and efficiency of the system and oil return to the compressor. The outdoor unit connections are flare type. Tube size should always be the same diameter as the connections provided at the service valves. Up sizing of lines can result in inadequate oil return to the compressor and excessive refrigerant charge and will void the warranty [See Table 1].

Refrigerant Piping		Model No.				
		CMA12SD-0	CMA18SD-1	CMA24SD-1	CMA30SD-1	CMA36SD-1
Liquid-Gas	In.	1/4 - 1/2		3/8 - 5/8	3/8 - 3/4	
Max. Refrigerant Line Length*	FL	65				
Max. Elevation Vertical Lift**	FL	33				

*Minimum pipe length must not be less than 15 feet.
 ** "P" trap risers every 10 ft. when outdoor unit is installed above indoor unit.

Choose a location that places the condensing unit as close to the indoor unit as possible. The maximum separation is dependent on model. Use only clean refrigeration grade tubing. Avoid piping on wet or rainy days. Always keep the tube ends capped until you are ready to make the final connections. Remove burrs from cut ends of tubing. Use tube benders to avoid kinking.

Insulate the suction line with Armaflex or equivalent with a wall thickness of at least 3/8". Support the tubing adequately to avoid sags that can trap oil. Isolate the tubing so as not to transmit noise to the building structure. Avoid sharp edges that could cut the tubes. Maximum vertical lift (compressor above evaporator) is dependent on model. Trap risers with a 'P' trap every 10 feet.

WARNING

It is illegal to discharge refrigerant into the atmosphere. Use proper reclaiming methods and equipment when working on the refrigerant containing parts of the unit. Service should be performed by a QUALIFIED service agency and certified technicians.

LEAK TEST, EVACUATION & RELEASE OF REFRIGERANT

The condensing unit is supplied with R-410a charge sufficient for most matching evaporator units. Charge must be added for interconnecting tubing.

The unit's service valves are shipped in the closed position and should not be opened until final connections leak testing and evacuation are completed.

The recommended procedure for leak test, evacuation, and release of refrigerant is outlined below:

1. Complete the final piping connections to the indoor and outdoor units using high temperature brazing alloy.
2. Connect a charging manifold to the service ports provided at the service valves.
3. Pressurize the lines and evaporator with nitrogen and leak check all connections with soap bubbles. Repair as necessary any faulty joints. If brazing is required be sure to RELEASE THE NITROGEN FIRST. Re-test as needed.
4. Connect a vacuum pump to the manifold center connection, start the pump and open the manifold valves.
5. Evacuate to 500 microns or less for a minimum of 30 minutes. Close the manifold valves and shut off the pump. Note the vacuum reading and wait 15 minutes. Take a new vacuum reading. A reading of 800 microns or higher indicates the presence of moisture or a leak.
6. Repair as necessary and repeat steps 3, 4 & 5.
7. Confirm that manifold valves are closed and disconnect the vacuum pump.
8. Remove the caps from the services valves. Open the valves to the fully 'back-seat' position. Replace service valve caps and tighten.

INITIAL START-UP & CHECKS

Operation of the unit is automatic and will provide cooling depending on the setting of the thermostat.

IMPORTANT!

All panels must be installed, main power turned on and the thermostat properly connected before operating the unit.

1. System check - set thermostat system switch to "Off" position and fan switch to "Auto" position. Turn the power supply breaker on.
2. Set the fan switch to "On," blower should operate.
3. Return the fan switch to "Auto". Blower should shut off. Set the system switch to "Cool" and lower thermostat set point to coldest setting. The compressor, condenser fan, and evaporator blower should all come on. Cool air will be supplied after a couple of minutes of run time.
4. Proceed to the "FIELD CHARGING" section of these instructions.

FIELD CHARGING

Unit performance, efficiency, and life depends, to a large extent, on a proper system charge. Time spent on getting the charge right at start-up will payoff in the long run. Operating conditions such as voltage, air flow, evaporator coil size, and indoor and outdoor temperature and humidity all have an effect on the system pressures and superheat conditions.

Charge must be added for the interconnecting tubing. Use of piston-style metering device is typical. Where TXVs are necessary due to AHRI-match or performance-related applications, a 15% bleed-type TXV is required. These units should be critically charged to ensure proper performance. Some systems may require additional charging of refrigerant, depending on line set lengths.

FINAL INSPECTION

Do a final visual inspection of the entire installation and complete any final details and clean up.

Review Unit Operation with the homeowner/user.

The pressure/temperature chart can be used as a reference to ensure performance.

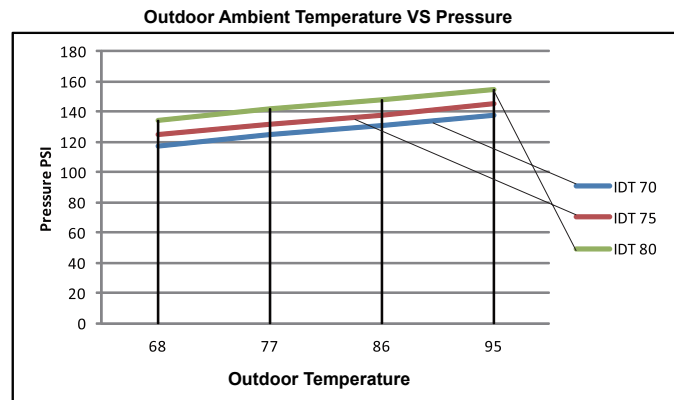

IDT \ ODT	68°F	77°F	86°F	95°F	PSI
70°F	117.7	125.0	130.8	138.0	
75°F	124.7	132.0	137.8	145.0	
80°F	134.7	142.0	147.8	155.0	

Note: "IDT" = Indoor Temperature
"ODT" = Outdoor Temperature

1. Remove refrigerant, if the pressure is above the chart value.
2. Add refrigerant, if the pressure is below the chart value.

Charging by Length of Pipe

Your condensing unit is pre-charged for the evaporator coil and 25 ft. of refrigerant line set. For lengths over 25 ft. use charging chart and formula below.

$$R = T \times (L-25)\text{ft}$$

R(oz): Additional refrigerant to be charged
L(ft): The length of the liquid pipe
T(oz): The quantity of the charged refrigerant per additional foot

MODEL	12	18	24	30	36	48
oz/ft	0.16			0.32		

LIMITED EXPRESS WARRANTY

'CMA' SERIES HORIZONTAL/SIDE DISCHARGE CONDENSERS

Congratulations on purchasing your new HVAC equipment. It's been designed for long life and reliable service, and is backed by one of the strongest warranties in the industry. Your unit automatically qualifies for the warranty coverage listed below, providing you keep your proof of purchase (receipt) for the equipment and meet the warranty conditions.

LIMITED ONE (1) YEAR PARTS EXPRESS WARRANTY

Heat Controller warrants all parts of the 'CMA' Series Condensing Unit to be free from defects in workmanship and materials normal use and maintenance for one (1) year from the date of purchase by the original consumer. This Express Limited Warranty applies only when the 'CMA' Series Condensing Unit is installed and operated per Heat Controller installation and operating instructions for normal use, and in accordance with all local, state and national codes.

LIMITED FIVE (5) YEAR COMPRESSOR EXPRESS WARRANTY

The compressor only is warranted to be free from defects in workmanship and materials under normal use and maintenance for four additional years, for a total of five (5) years from the date of purchase by the original consumer. This five year warranty applies only when the system is installed and operated per Heat Controller installation and operation instructions for normal use.

COMMERCIAL USE—LIMITED ONE (1) YEAR PARTS WARRANTY

When the unit is put to commercial, business, rental, or any application other than residential use, the One Year Parts Limited Warranty as described in paragraph one is the only warranty that applies.

EXCEPTIONS

The Limited Express Warranty does not cover normal maintenance—Heat Controller recommends that regular inspection/maintenance be performed at least once a season and proof of maintenance be kept. Additionally, labor charges, transportation charges for replacement parts, replacement of refrigerant or filters, any other service calls/repairs are not covered by this Limited Warranty. It also does not cover any portion or component of the system that is not supplied by Heat Controller, regardless of the cause of failure of such portion or component.

CONDITIONS FOR WARRANTY COVERAGE

- Unit must be operated according to Heat Controller operating instructions included with the unit and cannot have been subjected to accident, alteration, improper repair, neglect or misuse, or an act of God (such as a flood)
- Installation was done by a trained, licensed or otherwise qualified HVAC dealer/contractor
- Performance cannot be impaired by use of any product not authorized by Heat Controller, or by any adjustments or adaptations to components
- Serial numbers and/or rating plate have not been altered or removed
- Damage has not been a result of inadequate wiring or voltage conditions, use during brown-out conditions, or circuit interruptions
- Air flow around any section of the unit has not been restricted
- Unit remains in the original installation
- Unit was not purchased over the internet

DURATION OF WARRANTY & REGISTRATION

The warranty begins on the date of purchase by the original consumer. The consumer must retain a receipted bill of sale as proof of warranty period. Without this proof, the express warranty begins on the date of shipment from the factory.

REMEDY PROVIDED BY THE LIMITED EXPRESS WARRANTY

The sole remedy under the Limited Warranty is replacement of the defective part. If replacement parts are required within the period of this warranty, Heat Controller replacement parts shall be used; any warranty on the replacement part(s) shall not affect the applicable original unit warranty. Ready access to the unit for service is the owner's responsibility. Labor to diagnose and replace the defective part is not covered by this Limited Express Warranty. If for any reason the replacement part/product is no longer available during the warranty period, Heat Controller shall have the right to allow a credit in the amount of the current suggested retail price of the part/product instead of providing repair or replacement.

LIMITATION OF LIABILITY

1. There are no other express or implied warranties. Heat Controller makes no warranty of merchantability. We do not warrant that the unit is suitable for any particular purpose or can be used in buildings or rooms of any particular size or condition except as specifically provided in this document. There are no other warranties, express or implied, which extend beyond the description in this document.
2. All warranties implied by law are limited in duration to the one-year term of the parts warranty. Your exclusive remedy is limited to the replacement of defective parts. **We will not be liable for any consequential or incidental damages caused by any defect in this unit.**
3. This warranty gives you specific legal rights and you may also have other rights which vary from state to state. Some states do not allow limitation on how long an implied warranty lasts or do not allow the exclusion or limitation of incidental or consequential damages, so the above limitations or exclusions may not apply to you.
4. No warranties are made for units sold outside the continental United States and Canada. Your distributor or final seller may provide a warranty on units sold outside these areas.
5. Heat Controller will not be liable for damages if our performance regarding warranty resolution is delayed by events beyond our control including accident, alteration, abuse, war, government restrictions, strikes, fire, flood, or other acts of God.

HOW TO OBTAIN WARRANTY SERVICE OR PARTS

If you have a warranty claim, notify your installer promptly. If the installer does not remedy your claim, write to Heat Controller, 1900 Wellworth Ave., Jackson MI 49203. Enclose a report of inspection by your installer or service person. Include model number, serial number, and date of purchase.

Owner responsibilities are set forth in the instruction manual—read it carefully.

KEEP THIS INFORMATION AS A RECORD OF YOUR PURCHASE

'CMA' SERIES HORIZONTAL/SIDE DISCHARGE CONDENSING UNIT

Model Number	Model Number	Installer Name
Serial Number	Serial Number	Phone No./Contact Info
Date of Purchase	Date Installation Completed	

Remember to retain your bill of sale as proof of warranty period.

Due to ongoing product improvements, specifications and dimensions are subject to change and correction without notice or incurring obligations. Determining the application and suitability for use of any product is the responsibility of the installer. Additionally, the installer is responsible for verifying dimensional data on the actual product prior to beginning any installation preparations.

Incentive and rebate programs have precise requirements as to product performance and certification. All products meet applicable regulations in effect on date of manufacture; however, certifications are not necessarily granted for the life of a product. Therefore, it is the responsibility of the applicant to determine whether a specific model qualifies for these incentive/rebate programs.

Comfort-Aire®  **Century**®