

STANDARD FEATURES

- Direct-drive, multi-speed motors allow air volume variation for heating / cooling
- Multi-speed ECM motor: SWX series
- Fixed-speed PSC motor: SWP series
- Thermoplastic drain pan with bottom primary and secondary drain connections
- Built-in filter rack.
- Wall-hanging bracket included.
- Front or bottom return available.
- Optional heating elements in 5kW, 7.5kW, and 10kW.
- All-aluminum coil.
- AHRI listed and ETL listed.
- R454B refrigerant sensor is factory-installed.

SWP & SWX SERIES

WALL MOUNT AIR HANDLER

SWP Series - PSC Motor

SWX Series - ECM Motor

Cooling Capacity: 18 - 36 kBTU/h



Warranty – 5 years on unit parts. Unit cost replacement if heat exchanger, condenser coil, evaporator coil (packaged systems only), or compressor fails in the first year. With registration, 10 years on compressor and 20 years on heat exchanger.

(Limitations apply, see actual warranty for complete details.)

www.comfort-aire.com



MODEL NUMBER GUIDE

S	W	P	18	S	1	A
SE Series	Wall Mount Air Handler	Motor Type	Capacity BTUH x 1000	Standard Efficiency	Power 1 = 208/230-1-60	Revision

DIMENSIONAL DRAWING

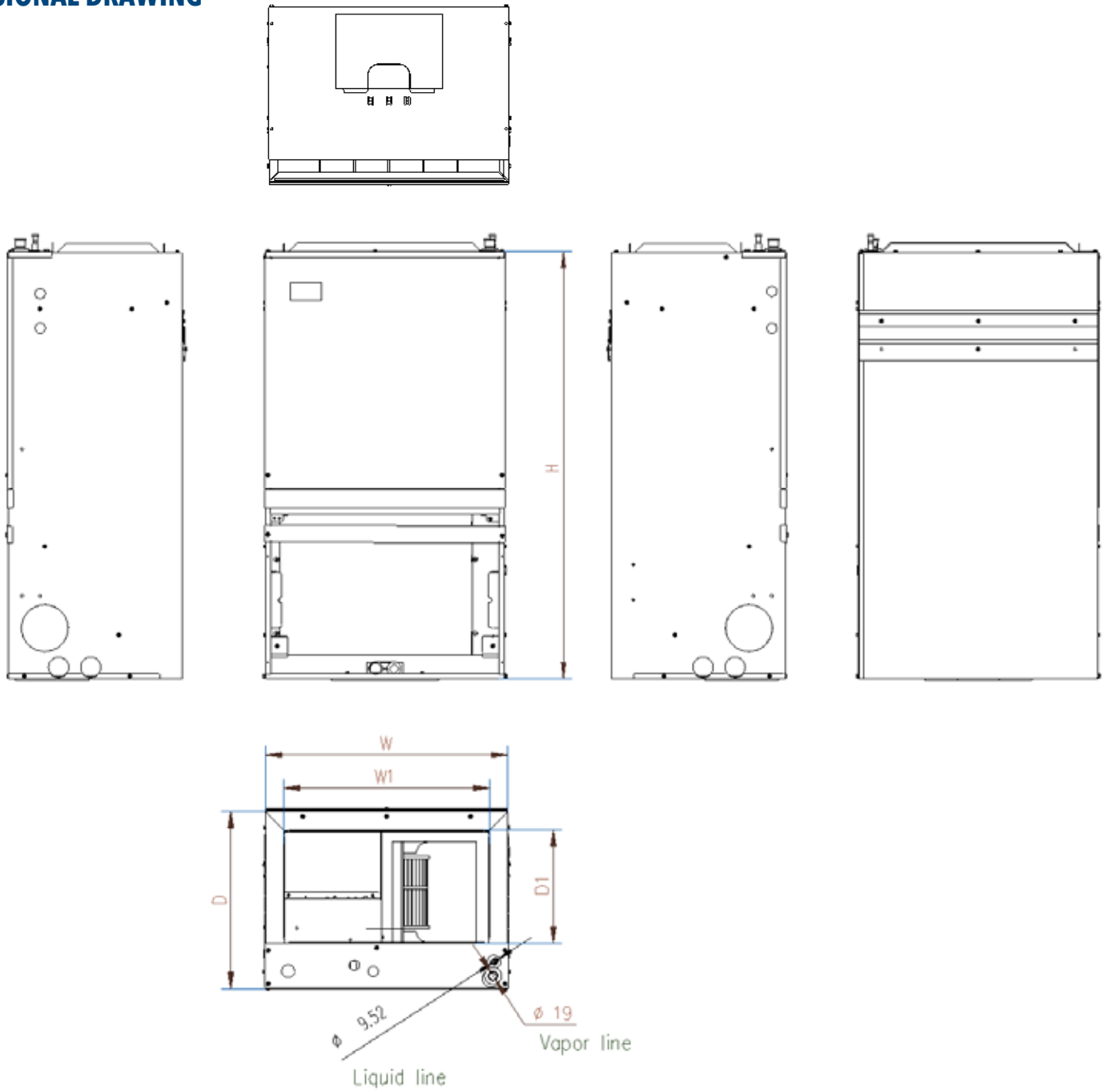

Model Size	Dimensions- (in.) [mm]				
	Height H	Width W	Width W1	Depth D	Depth D1
18K/24K	36 1/2 [928]	20 1/2 [521]	17 2/5 [442]	15 [381]	9 1/2 [242]
30K/36K	39 1/2 [1004]	22 [559]	18 4/5 [478]	19 [483]	9 1/2 [242]

SPECIFICATIONS

	SWP18S1A	SWP24S1A	SWP30S1A	SWP36S1A
NOMINAL RATING				
Cooling (BTU/h)	18,000	24,000	30,000	36,000
External Static Pressure (in.w.c)	0.6	0.6	0.6	0.6
ELECTRICAL DATA				
Voltage / Phase (60Hz)	208/230V-1Ph	208/230V-1Ph	208/230V-1Ph	208/230V-1Ph
Min. / Max. Voltage (V)	208/230V	208/230V	208/230V	208/230V
Min. Circuit Amps (MCA) (A)	1.2	1.7	2.8	2.8
Max. Overcurrent Protection (MOP) (A)	15	15	15	15
FAN MOTOR				
Motor Type	PSC	PSC	PSC	PSC
Capacitor (uF)	6	6	15	10
Horsepower (HP)	1/6	1/5	1/3	1/3
Rated RPM	650	750	1130	1150
Full Load Amps (FLA) (A)	0.9	1.3	2.2	2.2
REFRIGERANT DETECTOR				
Number of Detector	1	1	1	1
Type	TC/NDIR	TC/NDIR	TC/NDIR	TC/NDIR
Detection Threshold Limit Value (DTLV)	0.1	0.1	0.1	0.1
Measurement Range	0~100%	0~100%	0~100%	0~100%
Operating temp (°F)	-22~158	-22~158	-22~158	-22~158
FAN BLOWER				
Material	Metal	Metal	Metal	Metal
Type	Centrifugal	Centrifugal	Centrifugal	Centrifugal
Diameter (in.)	10	10	10	10
Height (in.)	6	6	9	9
EVAPORATOR COIL				
Type	Tube & Fin	Tube & Fin	Tube & Fin	Tube & Fin
Tube Material	Aluminum	Aluminum	Aluminum	Aluminum
Tube Size (mm)	7	7	7	7
Sound Pressure Level dBA	49	52	53	54
REFRIGERANT CONNECTION SIZE				
Liquid Line Size	3/8	3/8	3/8	3/8
Suction Line Size	3/4	3/4	3/4	3/4

SPECIFICATIONS

	SWX18S1A	SWX24S1A	SWX30S1A	SWX361A
NOMINAL RATING				
Cooling (BTU/h)	18,000	24,000	30,000	36,000
External Static Pressure (in.w.c)	0.6	0.6	0.6	0.6
ELECTRICAL DATA				
Voltage / Phase (60Hz)	208/230V-1Ph	208/230V-1Ph	208/230V-1Ph	208/230V-1Ph
Min. / Max. Voltage (V)	208/230V	208/230V	208/230V	208/230V
Min. Circuit Amps (MCA) (A)	2.4	2.4	3.4	3.4
Max. Overcurrent Protection (MOP) (A)	15	15	15	15
FAN MOTOR				
Motor Type	ECM	ECM	ECM	ECM
Horsepower (HP)	1/3	1/3	1/2	1/2
Rated RPM	650	800	1100	1120
Full Load Amps (FLA) (A)	1.9	1.9	2.7	2.7
REFRIGERANT DETECTOR				
Number of Detector	1	1	1	1
Type	TC/NDIR	TC/NDIR	TC/NDIR	TC/NDIR
Detection Threshold Limit Value (DTLV)	0.1	0.1	0.1	0.1
Measurement Range	0~100%	0~100%	0~100%	0~100%
Operating temp (°F)	-22~158	-22~158	-22~158	-22~158
FAN BLOWER				
Material	Metal	Metal	Metal	Metal
Type	Centrifugal	Centrifugal	Centrifugal	Centrifugal
Diameter (in.)	10	10	10	10
Height (in.)	6	6	9	9
EVAPORATOR COIL				
Type	Tube & Fin	Tube & Fin	Tube & Fin	Tube & Fin
Tube Material	Aluminum	Aluminum	Aluminum	Aluminum
Tube Size (mm)	7	7	7	7
Sound Pressure Level dBA	49	52	53	54
REFRIGERANT CONNECTION SIZE				
Liquid Line Size	3/8	3/8	3/8	3/8
Suction Line Size	3/4	3/4	3/4	3/4



Comfort-Cire®

SWP SERIES - ELECTRICAL CHARACTERISTICS

Heater Kit Electrical Data

Air Handler Model	Heat Kit	Electric Heat (kw)	Min. Circuit Ampacity		Max Fuse or Breaker (HACR) Ampacity	
			240V	208V	240V	208V
18	EHK2-05B	5	27.0	23.7	30.0	30.0
	EHK2-08B	7.5	40.2	35.0	50.0	50.0
	EHK2-10B	10	53.3	46.3	60.0	60.0
24	EHK2-05B	5	27.7	24.2	30.0	30.0
	EHK2-08B	7.5	40.7	35.5	50.0	50.0
	EHK2-10B	10	53.8	46.8	60.0	60.0
30	EHK2-05B	5	28.8	25.4	30.0	30.0
	EHK2-08B	7.5	41.9	36.7	50.0	50.0
	EHK2-10B	10	54.9	47.9	60.0	60.0
36	EHK2-05B	5	28.6	25.1	30.0	30.0
	EHK2-08B	7.5	41.6	36.4	50.0	50.0
	EHK2-10B	10	54.6	47.7	60.0	60.0

SWX SERIES - ELECTRICAL CHARACTERISTICS

Heater Kit Electrical Data

Air Handler Model	Heat Kit	Electric Heat (kw)	Min. Circuit Ampacity		Max Fuse or Breaker (HACR) Ampacity	
			240V	208V	240V	208V
18	EHK2-05B	5	28.4	24.9	30.0	30.0
	EHK2-08B	7.5	41.4	36.2	50.0	50.0
	EHK2-10B	10	54.5	47.5	60.0	60.0
24	EHK2-05B	5	28.4	24.9	30.0	30.0
	EHK2-08B	7.5	41.4	36.2	50.0	50.0
	EHK2-10B	10	54.5	47.5	60.0	60.0
30	EHK2-05B	5	29.4	25.9	30.0	30.0
	EHK2-08B	7.5	42.4	37.2	50.0	50.0
	EHK2-10B	10	55.5	48.5	60.0	60.0
36	EHK2-05B	5	29.4	25.9	30.0	30.0
	EHK2-08B	7.5	42.4	37.2	50.0	50.0
	EHK2-10B	10	55.5	48.5	60.0	60.0

ELECTRIC HEATER POWER WIRING DIAGRAMS

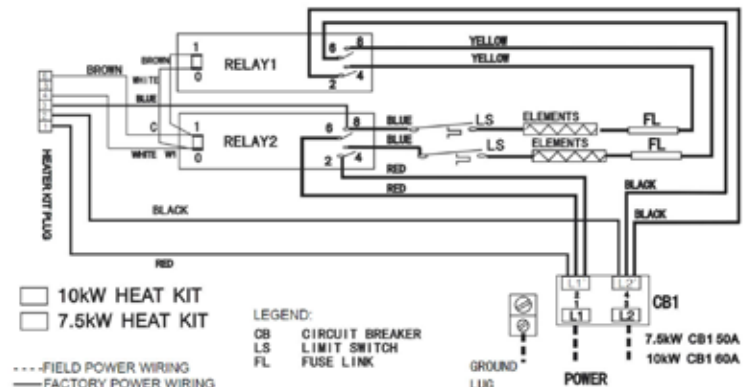
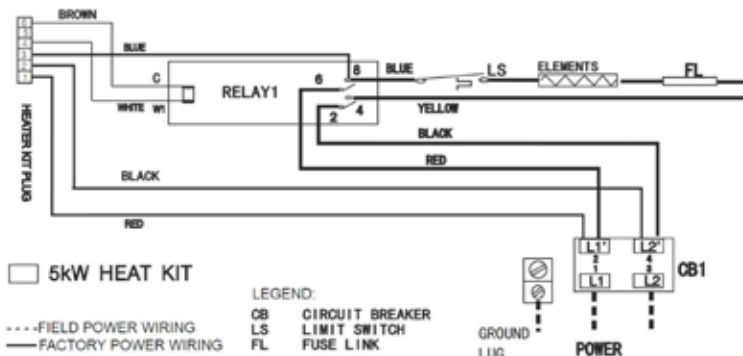

WIRING DIAGRAM

SEE NAME PLATE FOR VOLT&HERTZ
FIELD POWER WIRING

CAUTION:
NOT SUITABLE FOR USE ON SYSTEMS EXCEEDING 150V TO GROUND
ATTENTION:
NE CONVIENT PAS AUX INSTALLATIONS DE PLUS DE 150V ALA TERRE

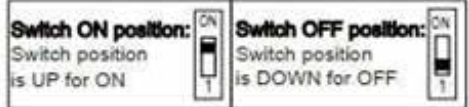
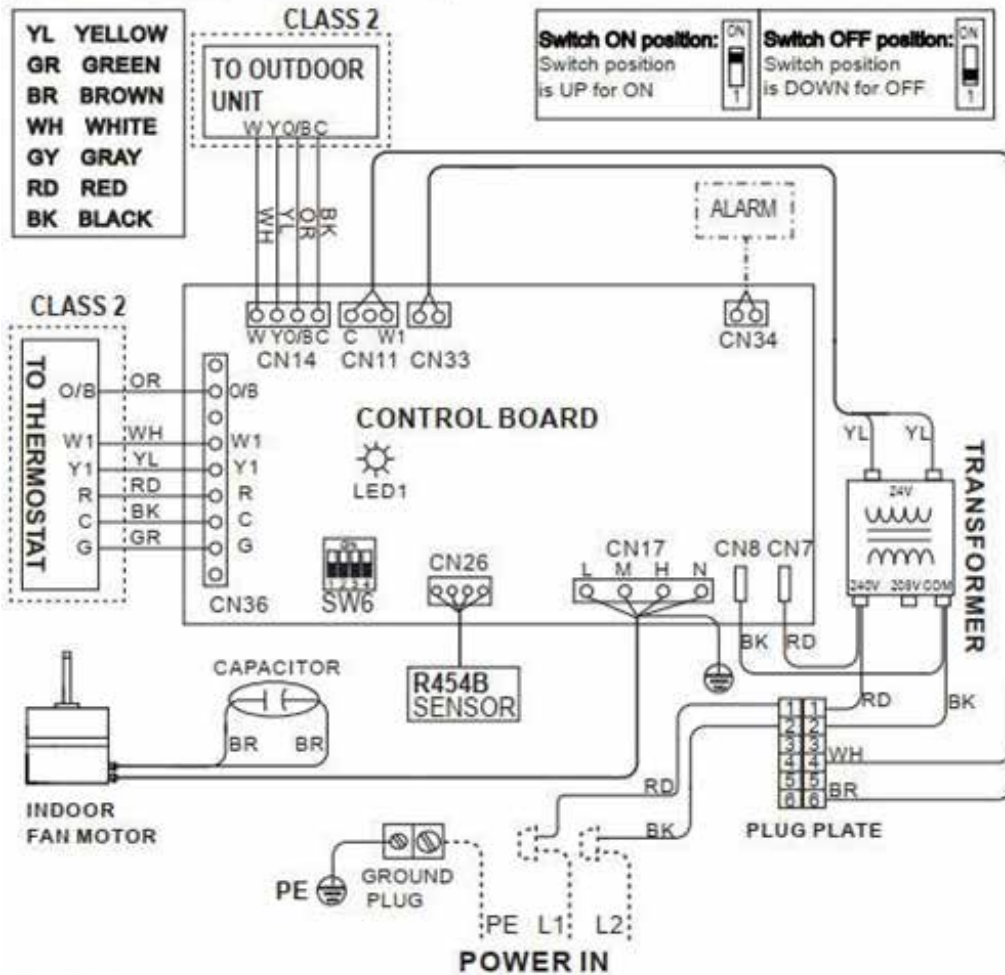

DETAILED REFERENCE
MANUAL INSTRUCTIONS

	BLACK BLOCK IS BUTTON	G	W/W1
SW6-1,2 FAN SPEED TAPS		L	H
		L	H
		M	H
		H	H
NOT USED			
SW6-3,4		FACTORY DEFAULT	

SPEED TAPS

L	LOW
M	MEDIUM
H	HIGH

----- **OPTIONAL**
- - - - - **FIELD INSTALLED**

NOTES:

- 1: Connect R to R, G to G, Y to Y, etc. See outdoor instruction for details.
 - 2: If some signal lines of CN36 are not used, please wrap them up separately with CAP.
- CAUTION:**
- 1: Use copper wire (75 C min) only between disconnect switch and unit.
 - 2: To be wired in accordance with NEC and local codes.
 - 3: If any of the original wires, as supplied, must be replaced. Use the same or equivalent type wires.
 - 4: If the input voltage is 208 V, please change the transformer tap by taking the red wire to 208V terminal.
 - 5: The rated operating condition of Alarm is 24 VAC/1A or 30 VDC/1A or 250 VAC/1A. Please refer to the manual for wiring methods.

LED1 STATUS	CONTENT
	STEADY ON
	OFF
	STEADY FLASHING
	3 FLASH/CYCLE
	4 FLASH/CYCLE
	8 FLASH/CYCLE
	R454B REFRIGERANT SENSOR FAULT
	R454B REFRIGERANT SENSOR COMMUNICATION FAULT
	R454B REFRIGERANT SENSOR OVER SERVICE LIFE

Factory code	Date	Revision
16023000014593	Jan. 18th, 2024	C

SWX SERIES

WIRING DIAGRAM

SEE NAME PLATE FOR VOLT&HERTZ
FIELD POWER WIRING

CAUTION:
NOT SUITABLE FOR USE ON SYSTEMS EXCEEDING 150V TO GROUND
ATTENTION:
NE CONVIENT PAS AUX INSTALLATIONS DE PLUS DE 150V ALA TERRE

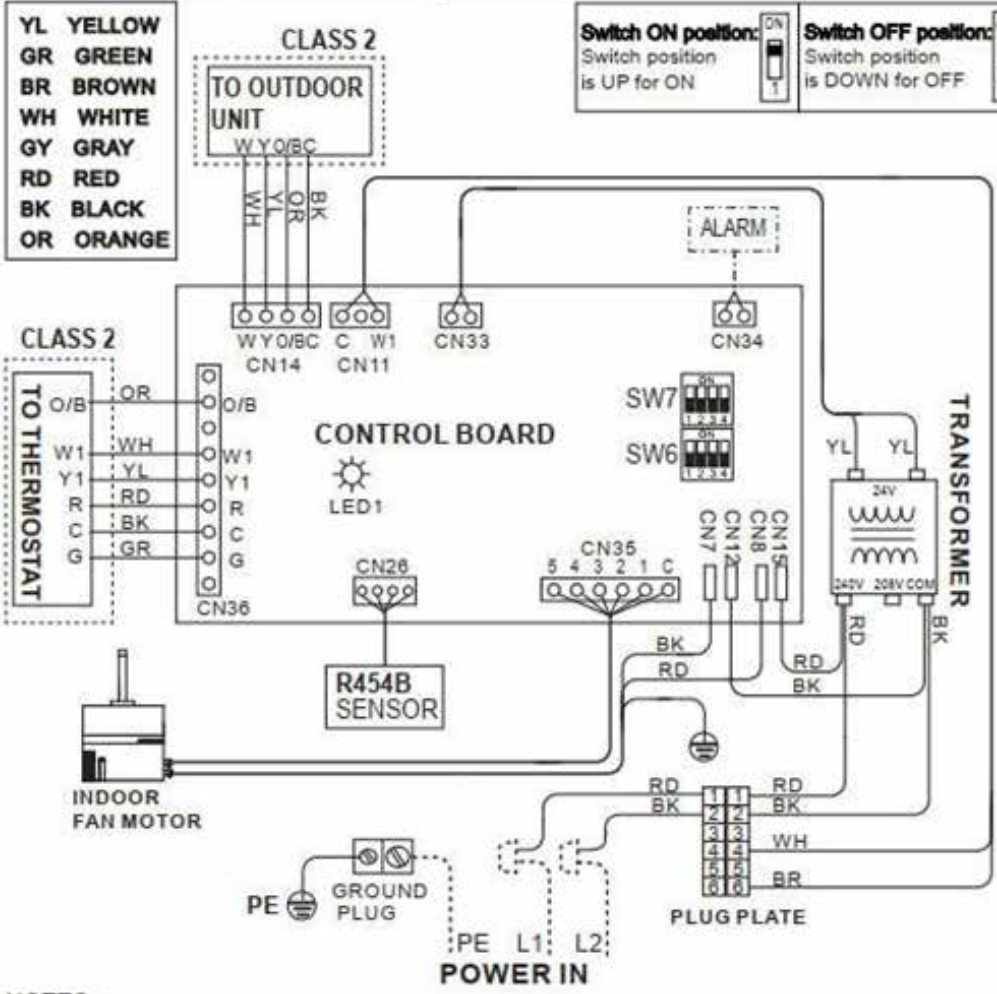

Switch ON position: Switch position is UP for ON

Switch OFF position: Switch position is DOWN for OFF

DETAILED REFERENCE MANUAL INSTRUCTIONS

BLACK BLOCK IS BUTTON	G	W/W1
	2	3
	3	4
	4	5
	5	5

NOT USED

SW6-3,4	FACTORY DEFAULT
SW7-1,2	FACTORY DEFAULT
SW7-3,4	FACTORY DEFAULT

SPEED TAPS

	LOW
	MEDIUM LOW
	MEDIUM
	MEDIUM HIGH
	HIGH

..... **OPTIONAL**
..... **FIELD INSTALLED**

- NOTES:**
- 1: Connect R to R, G to G, Y to Y, etc. See outdoor instruction for details.
 - 2: If some signal lines of CN36 are not used, please wrap them up separately with CAP.
- CAUTION:**
- 1: Use copper wire (75°C min) only between disconnect switch and unit.
 - 2: To be wired in accordance with NEC and local codes.
 - 3: If any of the original wires, as supplied, must be replaced. Use the same or equivalent type wires.
 - 4: If the input voltage is 208 V, please change the transformer tap by taking the red wire to 208V terminal.
 - 5: The rated operating condition of Alarm is 24 VAC/1A or 30 VDC/1A or 250 VAC/1A. Please refer to the manual for wiring methods.

LED1 STATUS	CONTENT	
	STEADY ON NORMAL OPERATION	
	OFF POWER SUPPLY FAILURE	
	STEADY FLASHING DISSIPATION MODE ACTIVE	
	3 FLASH/CYCLE R454B REFRIGERANT SENSOR FAULT	
	4 FLASH/CYCLE R454B REFRIGERANT SENSOR COMMUNICATION FAULT	
	8 FLASH/CYCLE R454B REFRIGERANT SENSOR OVER SERVICE LIFE	
Factory code	Date	Revision
16023000014592	Jan. 18th, 2024	C

AIRFLOW DATA

SWP	BLOWER SPEEDS	EXTERNAL STATIC PRESSURE (in. w. c.)								
		0	0.1	0.2	0.3	0.4	0.5	0.6	0.7	0.8
18 (1-1/2)	Low	604	562	527	485	441	387	-	-	-
	Med	697	655	619	577	533	479	426	380	
	High (default setting)	802	761	721	682	637	592	541	481	408
24 (2)	Low	665	629	589	547	508	480	-	-	-
	Med	831	786	741	696	655	609	559	497	-
	High (default setting)	932	881	833	786	742	689	636	574	515
30 (2-1/2)	Low	988	948	900	862	816	772	719	642	613
	Med (default setting)	1197	1152	1097	1046	998	940	886	821	737
	High	1338	1284	1220	1159	1096	1029	960	879	792
36 (3)	Low	1118	1072	1018	971	920	876	819	759	693
	Med	1262	1213	1160	1098	1049	998	937	871	804
	High (default setting)	1360	1311	1263	1229	1166	1074	1005	934	867

--- NOTES: Shaded boxes represent airflow outside the required 300-450 CFM/ton.

- Airflow based on dry coil at 230V with no electric heat and factory-approved filter. FMA5X airflow at 208V is approximately the same as 230V because the multi-tap ECM motor is a constant torque with no drop off regardless of motor operating speed.
- Airflow is equivalent for front or bottom return configurations.

SWX	BLOWER SPEEDS	EXTERNAL STATIC PRESSURE (in. w. c.)								
		0	0.1	0.2	0.3	0.4	0.5	0.6	0.7	0.8
18 (1-1/2)	Tap (1)	584	541	487	441	416	357	359	299	253
	Tap (2)	662	615	582	542	514	467	427	385	351
	Tap (3) (default setting)	710	683	645	619	579	535	490	458	416
	Tap (4)	803	769	742	710	675	642	609	572	534
	Tap (5)	899	871	836	810	789	758	719	689	646
24 (2)	Tap (1)	584	541	487	441	416	357	359	299	253
	Tap (2)	662	615	582	542	514	467	427	385	351
	Tap (3)	710	683	645	619	579	535	490	458	416
	Tap (4)	803	769	742	710	675	642	609	572	534
	Tap (5) (default setting)	899	871	836	810	789	758	719	689	646
30 (2-1/2)	Tap (1)	1063	1012	936	898	853	823	780	740	701
	Tap (2)	1133	1080	1026	991	958	904	858	813	769
	Tap (3) (default setting)	1220	1194	1111	1100	1060	1007	952	910	855
	Tap (4)	1234	1200	1146	1229	1088	1046	1004	951	917
	Tap (5)	1341	1310	1247	1225	1192	1151	1101	1077	1033
36 (3)	Tap (1)	1063	1012	936	898	853	823	780	740	701
	Tap (2)	1133	1080	1026	991	958	904	858	813	769
	Tap (3)	1220	1194	1111	1100	1060	1007	952	910	855
	Tap (4) (default setting)	1234	1200	1146	1229	1088	1046	1004	951	917
	Tap (5)	1341	1310	1247	1225	1192	1151	1101	1077	1033

--- NOTES: Shaded boxes represent airflow outside the required 300-450 CFM/ton.

- Airflow data includes electric heat and filter.
- Airflow data is with no return grill. When using a return grill on 18 & 24 sizes, decrease numbers above by approx. 10 CFM. For 30 & 36 sizes, decrease numbers above by approx. 50 CFM.

"This product complies with all California product labeling laws including, but not limited to, the Safe Drinking Water and Toxic Enforcement Act of 1986, more commonly known as Proposition 65."

Due to ongoing product improvements, specifications and dimensions are subject to change and correction without notice or incurring obligations.