

*Comfort-Cure*®

## Room Air Product Catalog

---

[www.heatcontroller.com](http://www.heatcontroller.com)

**HEAT**  **CONTROLLER**  
*Confidence in any climate*

# Comfort-Aire®

## TABLE OF CONTENTS

The full range of Comfort-Aire products for the Room Air market is presented in this catalog. Products are grouped into categories for your convenience and each section is color-coded, as shown below.

This catalog represents the latest information available at time of publication; however, because of on-going product improvements, we reserve the right to change design, specifications, performance data and materials without notice.

■ Room Air Accessories.....	1
■ Room Air Display Racks .....	1
■ Room Air Cooling.....	2-3
■ Cooling With Electric Heat .....	3-4
■ Thru-the-Wall Cooling .....	4-5
■ Thru-the-Wall Heating.....	5
■ Installation Tips.....	6
■ Casement Cooling.....	6
■ Heat Pumps.....	6
■ Portables .....	7
■ Specifications .....	8-9
■ Portable Cube Dehumidifiers .....	10-11
■ Dehumidifiers .....	12
■ Mini-Splits .....	13-15
■ 26" PTACs.....	16
■ 42" PTACs .....	17



Comfort-Aire room air products with the smartphone icon can be controlled from anywhere through the cloud using an app on iOS or Android. It also works with Google Assistant and Alexa



Comfort-Aire room air products come charged with the environmentally friendly R-454B, R410A and R-32 refrigerant



All Comfort-Aire room air products are listed with either CSA or UL for application in the United States and Canada. See the model rating plate for specific certifications

# Tips for SIZING

Room air units are an economical and practical means of adding comfort to a home, commercial space, warehouse office, or other area. For best results, the air conditioner or room heat pump should be correctly sized for the space. The specifications in this catalog show the approximate square footage which each unit effectively cools. However, other factors should be considered in selecting model size—it would be a good idea to choose the next size up if there are multiple doors and windows in the space, if ceilings are exceptionally high, if heat-generating equipment is used, or if several people occupy the space.

Use the chart below as a quick reference in determining which unit(s) will fit your needs.

Square Feet to be conditioned	Square Meters to be conditioned	Capacity Needed (BTUH)
100 - 150	9.3 - 13.9	5,000
150 - 250	13.9 - 23.2	6,000
250 - 300	23.2 - 27.9	7,000
300 - 350	27.9 - 32.5	8,000
350 - 400	32.5 - 37.2	9,000
400 - 450	37.2 - 41.8	10,000
450 - 550	41.8 - 51.1	12,000
550 - 700	51.1 - 65.1	14,000
700 - 1,000	65.1 - 92.9	18,000
1,000 - 1,200	92.9 - 111.5	21,000
1,200 - 1,400	111.5 - 130.1	23,000
1,400 - 1,500	130.1 - 139.4	25,000
1,500 - 2,000	139.4 - 185.8	30,000

Guidelines from [www.energystar.gov](http://www.energystar.gov)

Energy Star recommends increasing capacity by 10% for a sunny room, decreasing by 10% for shaded room.

If used in a kitchen, add 4,000 BTUHs to the total.

If more than two people regularly use the room, add 600 BTUH for each additional person.

## ROOM AIR ACCESSORIES

### Window Support Brackets

Easy-to-install brackets add a full measure of safety to window-mounted air conditioners. Manufactured from heavy gauge steel with a durable baked-on epoxy finish, the brackets have stainless steel hardware to resist weather damage. Unique bubble level helps ensure proper installation angle.

**AS080**—For room air conditioners up to 80 pounds

Box Dimensions (in.) - 4 x 12 x 2

**AS160**—For room air conditioners up to 160 pounds

Box Dimensions (in.) - 4 x 17 x 2



Both brackets install and remove with no structural disturbance

**NTN-1**—No screws or penetrations, simple, yet robust design

Box Dimensions (in.) - 23T x 2.25D x 3.25W



**NTN-2**—No screws or penetrations, easy "drop in" installation

Box Dimensions (in.) - 11T x 16D x 14W

## ROOM AIR DISPLAY RACKS

### Mini-Split Display Rack



**Part #6077**  
28 1/4"W x 21-1/2"D & is 74" H  
(Header Not Included)

**Part #6078**  
Comfort-Aire Header

### Room Air Display Rack



**Part # 8374**  
30"W x 27"D & is 72" H  
(rack includes header)

## COOLING • 5,000 to 6,000 BTUH



**RG-51R**

**5,000 BTUH**  
Nominal

### FEATURES

- Electro-mechanical seven-position control for easy temperature selection
- Adjustable thermostat from minimal cooling to maximum cooling
- Easy to access, slide-out filter is washable
- Adjustable air direction
- Compact, lightweight cabinet with attractive decorator front grille



**RADS-51Q**

**5,000 BTUH**  
Nominal

### FEATURES

- Electronic controls with remote
- Two-way adjustable air direction
- Easy-access, slide-out, washable filter
- One degree temperature adjustment
- 24-hour on/off timer and auto restart, energy saver function; auto, dehumidification and sleep modes



**RADS-61R**

**6,000 BTUH**  
Nominal

### FEATURES

- Electronic controls with full feature remote and auto restart
- Four-way adjustable air direction
- Easy-access, slide-out, washable filter
- One degree temperature adjustment
- 24-hour on/off timer and auto restart, energy saver function; auto, dehumidification and sleep modes

## COOLING • 8,000 to 12,000 BTUH



**RADS-81R03**

**8,000 BTUH**  
Nominal

### FEATURES

- Electronic controls with full feature remote and auto restart
- Four-way adjustable air direction
- Easy-access, slide-out, washable filter
- One degree temperature adjustment
- 24-hour on/off timer and auto restart, energy saver function; auto, dehumidification and sleep modes



**RADS-101R03**

**10,000 BTUH**  
Nominal

### FEATURES

- Electronic controls with full feature remote and auto restart
- Four-way adjustable air direction
- Easy-access, slide-out, washable filter
- One degree temperature adjustment
- 24-hour on/off timer and auto restart, energy saver function; auto, dehumidification and sleep modes



**RADS-121R03**

**12,000 BTUH**  
Nominal

### FEATURES

- Electronic controls with full feature remote and auto restart
- Four-way adjustable air direction
- Easy-access, slide-out, washable filter
- One degree temperature adjustment
- 24-hour on/off timer and auto restart, energy saver function; auto, dehumidification and sleep modes

## COOLING • 15,000 to 25,000 BTUH



**RADS-151R01** **15,000 BTUH**  
Nominal

### FEATURES

- Electronic controls with full feature remote and auto restart
- Four-way adjustable air direction
- Easy-access, slide-out, washable filter
- One degree temperature adjustment
- Energy saver function, 24-hour on/off timer, dehumidification and auto modes



**RADS-183S** **18,000 BTUH**  
Nominal

### FEATURES

- Electronic controls with full feature remote and auto restart
- Four-way adjustable air direction
- Easy-access, slide-out, washable filter
- One degree temperature adjustment
- Energy saver function, 24-hour on/off timer, dehumidification and auto modes
- Slide out Chassis



**RADS-253R03** **25,000 BTUH**  
Nominal

### FEATURES

- Electronic controls with full feature remote and auto restart
- Four-way adjustable air direction
- Easy-access, slide-out, washable filter
- One degree temperature adjustment
- Energy saver function, 24-hour on/off timer, dehumidification and auto modes
- Slide out Chassis



## COOLING • 28,000 BTUH



**RAD-283S** **28,000 BTUH**  
Nominal

### FEATURES

- Large capacity cooling for residential or commercial applications
- Electronic controls with full feature remote and auto restart
- Four-way adjustable air direction
- Easy-access, slide-out, washable filter
- Energy saver function, 24-hour on/off timer, dehumidification and auto modes

## COOLING/ELECTRIC HEAT • 8,000 to 12,000 BTUH



**REG-81R01** **8,000 BTUH**  
Nominal

### FEATURES

- Electronic controls with full feature remote, 24-hour on/off timer
- Energy saver mode, auto restart
- Four way adjustable air direction
- One degree temperature adjustment
- Designed for supplemental electric heat only, thermostat cycles heating element on and off



**REG-123R01** **12,000 BTUH**  
Nominal

### FEATURES

- Electronic controls with full feature remote, 24-hour on/off timer
- Energy saver mode, auto restart
- Four way adjustable air direction
- One degree temperature adjustment
- Designed for supplemental electric heat only, thermostat cycles heating element on and off

**COOLING/ELECTRIC HEAT • 18,000 to 23,200 BTUH**



**REG-183R01**      **18,000 BTUH**  
Nominal

**FEATURES**

- Electronic controls with full feature remote, 24-hour on/off timer
- Energy saver mode, auto restart
- Four-way adjustable air direction
- One degree temperature adjustment
- Designed for supplemental electric heat only, thermostat cycles heating element on and off
- Slide out Chassis



**REG-243R01**      **23,200 BTUH**  
Nominal

**FEATURES**

- Electronic controls with full feature remote, 24-hour on/off timer
- Energy saver mode, auto restart
- Four-way adjustable air direction
- One degree temperature adjustment
- Designed for supplemental electric heat only, thermostat cycles heating element on and off
- Slide out Chassis



**THRU-THE-WALL • 8,000 to 10,000 BTUH**



**BG-81R02**      **8,000 BTUH**  
Nominal

**FEATURES**

- Electronic controls with full feature remote and auto restart
- Four-way adjustable air direction
- Energy saver function and 24-hour on/off timer
- Auto and sleep modes
- Interior trim kit included
- Fits standard wall sleeves



**BG-101R02**      **10,000 BTUH**  
Nominal

**FEATURES**

- Electronic controls with full feature remote and auto restart
- Four-way adjustable air direction
- Energy saver function and 24-hour on/off timer
- Interior trim kit included
- Fits standard wall sleeves
- Auto and sleep modes



**BG-103R02**      **10,000 BTUH**  
Nominal

**FEATURES**

- Electronic controls with full feature remote and auto restart
- Four-way adjustable air direction
- Energy saver function and 24-hour on/off timer
- Interior trim kit included
- Fits standard wall sleeves
- Auto and sleep modes

## THRU-THE-WALL • 12,000 to 14,000 BTUH



**BG-121R02**

**12,000 BTUH**  
Nominal

### FEATURES

- Electronic controls with full feature remote and auto restart
- Four-way adjustable air direction
- Energy saver function and 24-hour on/off timer
- Interior trim kit included
- Fits standard wall sleeves
- Auto and sleep modes



**BG-123R02**

**12,000 BTUH**  
Nominal

### FEATURES

- Electronic controls with full feature remote and auto restart
- Four-way adjustable air direction
- Energy saver function and 24-hour on/off timer
- Interior trim kit included
- Fits standard wall sleeves
- Auto and sleep modes



**BG-143R01**

**14,000 BTUH**  
Nominal

### FEATURES

- Electronic controls with full feature remote and auto restart
- Four-way adjustable air direction
- Energy saver function and 24-hour on/off timer
- Interior trim kit included
- Fits standard wall sleeves
- Auto and sleep modes

## THRU-THE-WALL WITH ELECTRIC HEAT • 10,000 to 14,000 BTUH



**BGE-103R01**

**10,000 BTUH**  
Nominal

### FEATURES

- Electronic controls with full feature remote
- Four-way adjustable air direction
- Energy saver function, 24-hour on/off timer, auto cool and auto restart
- Interior trim kit included
- Fits standard wall sleeves
- Includes electric heat



**BGE-123R01**

**12,000 BTUH**  
Nominal

### FEATURES

- Electronic controls with full feature remote
- Four-way adjustable air direction
- Energy saver function, 24-hour on/off timer, auto cool and auto restart
- Interior trim kit included
- Fits standard wall sleeves
- Includes electric heat



**BGE-143R01**

**14,000 BTUH**  
Nominal

### FEATURES

- Electronic controls with full feature remote
- Four-way adjustable air direction
- Energy saver function, 24-hour on/off timer, auto cool and auto restart
- Interior trim kit included
- Fits standard wall sleeves
- Includes electric heat

## INSTALLATION TIPS

### Casement/Slider Windows

These windows which slide open to the side or open outward require a different type of window air conditioner. Our CD models are ideal for casement or slider windows. The window can close onto the sides of the unit, and a support platform is included. A plastic window filler panel is included with the unit—it can be cut to size and fits into an adjustable window panel frame. For a casement window, the window crank must be removed.

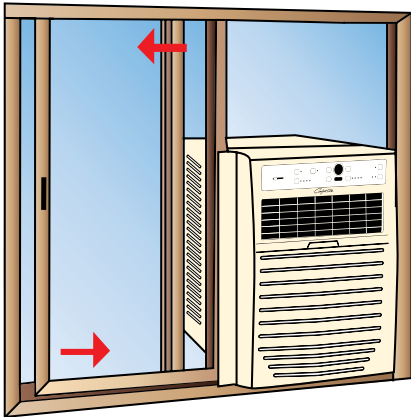

#### Slider Window

Filler panel fits into frame that is installed above the unit.

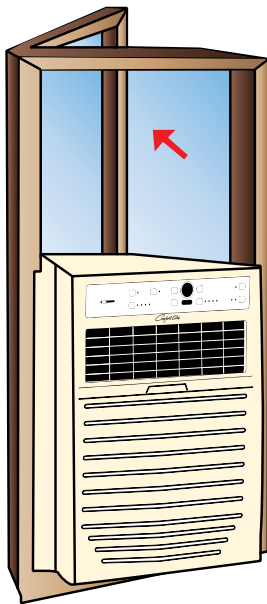

#### Casement Window

Window opens outward or the exterior pane may be removed. Crank mechanism is removed.

## CASEMENT/SLIDER • 8,000 to 10,000 BTUH



**CD-81R01**

**8,000 BTUH**  
Nominal

#### FEATURES

- For horizontal sliding or casement windows, fits opening 20<sup>5</sup>/<sub>16</sub>" to 39<sup>7</sup>/<sub>16</sub>" high, starting at 15<sup>1</sup>/<sub>2</sub>" wide
- Electronic controls and remote
- Four-way adjustable air direction
- Energy saver mode and 24-hour on/off timer, auto restart
- Slide out Chassis



**CD-101R01**

**10,000 BTUH**  
Nominal

#### FEATURES

- For horizontal sliding or casement windows, fits opening 20<sup>5</sup>/<sub>16</sub>" to 39<sup>7</sup>/<sub>16</sub>" high, starting at 15<sup>1</sup>/<sub>2</sub>" wide
- Electronic controls and remote
- Four-way adjustable air direction
- Energy saver mode and 24-hour on/off timer, auto restart
- Slide out Chassis

## HEAT PUMPS • 12,000 to 18,000 BTUH



**RAH-123R**

**12,000 BTUH**  
Nominal

#### FEATURES

- Electronic controls, wireless remote
- Sleep mode and 24-hour timer
- Thru-the-wall or window mount with support bracket included
- Cooling, heating, fan only and auto operation, energy saver mode
- Switches to supplemental electric heat at 40°F outside temperature (Not primary source of heat)
- Slide out Chassis



**RAH-183R**

**18,000 BTUH**  
Nominal

#### FEATURES

- Electronic controls, wireless remote
- Automatic louver swing
- Thru-the-wall or window mount with support bracket included
- Cooling, heating, fan only, energy saver mode, and 24-hour timer
- Switches to supplemental electric heat at 40°F outside temperature (Not primary source of heat)
- Slide out Chassis

*Comfort-Care*®

## PORTABLE COOLING • 8,000 to 12,000 BTUH



**PS-81G**

**8,000 BTUH**  
Nominal

### FEATURES

- Cool a room without any ductwork or any special wiring, and move the unit from room to room as needed
- Ideal wherever temporary cooling is needed or where a window A/C isn't an option
- Built-in condensate disposal
- 60" single hose for fast installation
- Automatic louver swing
- Washable filter is easily accessed
- 24-hour on/off timer, auto restart
- ASHRAE Standard 128-2001



**PS-101H**

**10,000 BTUH**  
Nominal

### FEATURES

- Cool a room without any ductwork or any special wiring, and move the unit from room to room as needed
- Ideal wherever temporary cooling is needed or where a window A/C isn't an option
- Built-in condensate disposal
- 60" single hose for fast installation
- Automatic louver swing
- Washable filter is easily accessed
- 24-hour on/off timer, auto restart
- ASHRAE Standard 128-2001



**PS-121H**

**12,000 BTUH**  
Nominal

### FEATURES

- Cool a room without any ductwork or any special wiring, and move the unit from room to room as needed
- Ideal wherever temporary cooling is needed or where a window A/C isn't an option
- Built-in condensate disposal
- 60" single hose for fast installation
- Automatic louver swing
- Washable filter is easily accessed
- 24-hour on/off timer, auto restart
- ASHRAE Standard 128-2001

## PORTABLE HEAT PUMP • 14,000 BTUH

## ADVANTAGES OF PORTABLE COOL/HEAT



**PSH-141H**

**14,000 BTUH**  
Nominal

### FEATURES

- Cool and heat a room without any ductwork or any special wiring, and move the unit from room to room as needed
- Ideal wherever temporary cooling is needed or where a window A/C isn't an option
- Built-in condensate disposal
- 60" single hose for fast installation
- Automatic louver swing
- Washable filter is easily accessed
- 24-hour on/off timer, auto restart
- ASHRAE Standard 128-2001

Portable air conditioners and heat/cool models are ideal for any area where temporary cooling (or heating) is needed, or in situations where a window air conditioner isn't an option.

Historical properties are ideal candidates for portables since the aesthetics of the building's exterior are maintained.

Also, additions to existing homes can be conditioned without upgrading the entire HVAC unit to accommodate the added square footage.

Some other applications that can benefit from the efficiency and portability of these units:

- Apartments
- College dormitory rooms
- Bedrooms and sunrooms
- Cottages/vacation homes
- Home workshops
- School and church classrooms
- Warehouse offices



A large diameter, 60" flexible hose effectively exhausts hot air to the outside.

# Specifications

## Powercord Configurations



15 AMP 115V  
PARALLEL  
A  
5-15P



15 AMP 230V  
TANDEM  
B  
6-15P



20 AMP 230V  
TEE  
C  
6-20P



30 AMP 230V  
TANDEM  
D  
6-30P

## Sizing Guidelines

Use the chart below as a quick reference in determining which unit(s) will fit your needs

Square Feet to be conditioned	Square Meters to be conditioned	Capacity Needed (BTUH)
100 - 150	9.3 - 13.9	5,000
150 - 250	13.9 - 23.2	6,000
250 - 300	23.2 - 27.9	7,000
300 - 350	27.9 - 32.5	8,000
350 - 400	32.5 - 37.2	9,000
400 - 450	37.2 - 41.8	10,000
450 - 550	41.8 - 51.1	12,000
550 - 700	51.1 - 65.1	14,000
700 - 1,000	65.1 - 92.9	18,000
1,000 - 1,200	92.9 - 111.5	21,000
1,200 - 1,400	111.5 - 130.1	23,000
1,400 - 1,500	130.1 - 139.4	25,000
1,500 - 2,000	139.4 - 185.8	30,000

Guidelines from [www.energystar.gov](http://www.energystar.gov)

Energy Star recommends increasing capacity by 10% for a sunny room, decreasing by 10% for shaded room.

If used in a kitchen, add 4,000 BTUHs to the total.

If more than two people regularly use the room, add 600 BTUH for each additional person.

Model	Cooling Capacity BTUH	Refrigerant Type	Approx. Sq. Ft. Cooling	EER	Heating Capacity BTUH (Electric)	Electric (Volts)	Humidity Removal Pints/Hr	Smartphone Compatible	Remote Control
<b>COOLING 5,000 to 28,000 BTUH</b>									
RG-51R	5,000	R-32	100-150	11.0	N/A	115	1.06	No	No
RADS-51Q	5,000	R-32	100-150	12.1	N/A	115	1.06	No	Yes
RADS-61R	6,000	R-32	150-250	12.1	N/A	115	1.48	Yes	Yes
RADS-81R03	8,000	R-32	300-350	11.4	N/A	115	1.9	Yes	Yes
RADS-101R03	10,000	R-32	400-450	11.4	N/A	115	2.33	Yes	Yes
RADS-121R03	12,000	R-32	450-550	11.4	N/A	115	2.54	Yes	Yes
RADS-151R01	14,500	R-32	550-700	11.3	N/A	115	3.17	Yes	Yes
RADS-183S	17,700/18,000	R-32	700-1,000	11.8	N/A	208/230	5.35	Yes	Yes
RADS-253R03	24,000/24,000	R-32	1,400-1,500	13.3	N/A	208/230	7.42	Yes	Yes
RAD-283S	27,600/28,000	R-32	1,500-2,000	9.4	N/A	208/230	6.34	Yes	Yes
<b>COOLING WITH ELECTRIC HEAT</b>									
REG-81R01	8,000	R-32	300-350	10.9	3500	115	1.9	Yes	Yes
REG-123R01	11,600/12,000	R-32	450-550	10.9	8,500/11,000	208/230	2.54	Yes	Yes
REG-183R01	18,200/18,500	R-32	700-1000	10.7	13,000/16,000	208/230	5.35	Yes	Yes
REG-243R01	22,900/23,200	R-32	1400-1500	9.4	13,000/16,000	208/230	7.42	Yes	Yes
<b>THRU-THE-WALL COOLING</b>									
BG-81R02	8,300	R-32	300-350	10.6	N/A	115	2.11	Yes	Yes
BG-101R02	10,000	R-32	400-450	10.6	N/A	115	2.32	Yes	Yes
BG-103R02	10,200/10,500	R-32	400-450	10.6	N/A	208/230	2.32	Yes	Yes
BG-121R02	12,000	R-32	450-550	10.5	N/A	115	2.54	Yes	Yes
BG-123R02	11,700/12,000	R-32	450-550	10.5	N/A	208/230	2.54	Yes	Yes
BG-143R01	13,600/14,000	R-32	550-700	9.5	N/A	208/230	2.96	Yes	Yes
<b>THRU-THE-WALL WITH ELECTRIC HEAT</b>									
BGE-103R01	9,800/10,000	R-32	400-450	9.6	8,600/10,600	208/230	2.32	Yes	Yes
BGE-123R01	11,700/12,000	R-32	450-550	9.5	8,600/10,600	208/230	2.54	Yes	Yes
BGE-143R01	13,600/14,000	R-32	550-700	9.5	8,600/10,600	208/230	2.96	Yes	Yes
<b>CASEMENT SERIES</b>									
CD-81R01	8,000	R-32	300-350	10.8	N/A	115	0.9	No	Yes
CD-101R01	10,000	R-32	400-450	10.4	N/A	115	1.1	No	Yes
<b>HEAT PUMPS</b>									
RAH-123R	11,200/11,600	R-32	450-550	9.9 / 9.9	9,900/10,200**	208/230	3.17	No	Yes
RAH-183R	17,000/17,300	R-32	700-1000	10.4 / 10.6	14,000/14,300**	208/230	4.65	No	Yes
<b>PORTABLE A/C</b>									
PS-81G	8,500	R-32	300-350	6.1	N/A	115	2.95	Yes	Yes
PS-101H	10,000	R-32	400-450	6.9	N/A	115	3.84	Yes	Yes
PS-121H	12,000	R-32	450-550	7.22	N/A	115	4.56	Yes	Yes
PSH-141H	13,500	R-32	550-700	7.83	11000	115	5.24	Yes	Yes
<b>PORTABLE CUBE DEHUMIDIFIERS</b>									
BCD-20A*	N/A	R-410	N/A	N/A	N/A	115	0.83	Yes	No
BCD-35A*	N/A	R-410	N/A	N/A	N/A	115	1.45	Yes	No
BCD-50A*	N/A	R-410	N/A	N/A	N/A	115	2.08	Yes	No
<b>PORTABLE DEHUMIDIFIERS</b>									
BHD-22B*	N/A	R-32	N/A	N/A	N/A	115	0.93	Yes	No
BHD-35B*	N/A	R-32	N/A	N/A	N/A	115	1.48	Yes	No
BHD-50B*	N/A	R-32	N/A	N/A	N/A	115	2.08	Yes	No
BHDP-50B*	N/A	R-32	N/A	N/A	N/A	115	2.08	Yes	No
BHDP-60B*	N/A	R-32	N/A	N/A	N/A	115	2.5	Yes	No

\*Energy Star® rated

\*\* Heat pump capacity

### IMPORTANT!

Always wait to cut an opening until the unit arrives and dimensions can be verified.



Model	Ventilation Control	Fan Only Speeds	Air Delivery Max. CFM	Fan Motor Speeds	Amps Cooling	Amps Heating	dB Level (hi/med/low)	Max Fuse Size Amps	Slide-Out Chassis	Window Mounting Kit (standard)	Power Cord Plug	Window Opening W x H (min/max)	Approx. Max-Wall Thickness (in.)	Ship Weight (lbs.)	Dimensions H x W x D (with base and front in inches)
<b>COOLING 5,000 to 28,000 BTUH</b>															
RG-51R	No	2	145	2	4.6	N/A	56/52	15	No	Yes	A	23/36 x 13	3.3	40	12.0 x 16.0 x 13.2
RADS-51Q	No	3	150	3	4	N/A	57/54/53	15	No	Yes	A	23/36 x 14	3.3	44	12.0 x 16.0 x 13.2
RADS-61R	No	3	169	3	4.5	N/A	56/53/52	15	No	Yes	A	23/36 x 14	5	49	13.4 x 18.5 x 15.7
RADS-81R03	No	3	188	3	6.27	N/A	61/58/54	15	No	Yes	A	23/36 x 14	5.7	54	13.4 x 18.5 x 15.7
RADS-101R03	Yes	3	317	3	7.8	N/A	61/58/54	15	No	Yes	A	23/36 x 15.5	7.3	66	14.6 x 21.5 x 19
RADS-121R03	Yes	3	320	3	10.1	N/A	61/56/58	15	No	Yes	A	23/36 x 15.5	7.3	75	14.6 x 21.5 x 19.0
RADS-151R01	Yes	3	298	3	11.8	N/A	61/56/58	15	No	No	A	23/36 x 15.5	8	79	14.6 x 21.5 x 19.0
RADS-183S	Yes	3	363	3	7.2/7.6	N/A	58/56/55	15	Yes	Yes	B	28/40.5 x 18.5	8	133	17.9 x 25.4 x 23.6
RADS-253R03	Yes	3	461	3	11.5/12.8	N/A	59/59/58	20	Yes	Yes	C	31/42 x 19.5	10	149	17.91 x 25.39 x 23.62
RAD-283S	Yes	3	461	3	13.9/14.7	N/A	61/60/60	30	No	Yes	D	31/42 x 19.5	10	155	18.6 x 26.5 x 26.5
<b>COOLING WITH ELECTRIC HEAT</b>															
REG-81R01	No	3	308	3	8.9	11.9	66/60/57	15	No	Yes	A	36.8/36 x 16.5	6.1	68	14.7 x 19 x 21.5
REG-123R01	No	3	319	3	6.1/6.9	14.5/15.7	61/58/55	20	No	Yes	C	36.8/36 x 16.5	6.1	79	14.7 x 19 x 21.5
REG-183R01	Yes	3	449	3	7.7/8.3	22/20	69/67/65	30	Yes	Yes	D	36.8/40.5 x 18.5	8	132	17.9 x 23.6 x 25.4
REG-243R01	Yes	3	477	3	10.8/11.8	22/20	68/66/64	30	Yes	Yes	D	36.8/40.5 x 18.5	10	136	17.9 x 23.6 x 25.4
<b>THRU-THE-WALL COOLING</b>															
BG-81R02	No	3	270	3	7.8	N/A	56/53/50	15	No	Yes <sup>▲</sup>	A	26.8/36 x 15.5	18.0	77	14.5 x 24.2 x 20.3
BG-101R02	No	3	256	3	10	N/A	56/53/50	15	No	Yes <sup>▲</sup>	A	26.8/36 x 15.5	18.0	79	14.5 x 24.2 x 20.3
BG-103R02	No	3	291	3	4.7/5.1	N/A	59/58/56	15	No	Yes <sup>▲</sup>	B	26.8/36 x 15.5	18.0	80	14.5 x 24.2 x 20.3
BG-121R01	No	3	276	3	11.3	N/A	59/57/55	15	No	Yes <sup>▲</sup>	A	26.8/36 x 15.5	18.0	88	14.5 x 24.2 x 20.3
BG-123R02	No	3	274	3	5.6/6.3	N/A	60/59/58	15	No	Yes <sup>▲</sup>	B	26.8/36 x 15.5	18.0	87	14.5 x 24.2 x 20.3
BG-143R01	No	3	280	3	7.0/7.7	N/A	61/60/58	15	No	Yes <sup>▲</sup>	B	26.8/36 x 15.5	18.0	88	14.5 x 24.2 x 20.3
<b>THRU-THE-WALL WITH ELECTRIC HEAT</b>															
BGE-103R01	No	3	286	3	5.1/5.5	15.0/13.5	66/63/61	20	No	Yes <sup>▲</sup>	C	26.8/36 x 15.5	18.0	79	14.5 x 24.2 x 20.3
BGE-123R01	No	3	274	3	6.5/7.0	15.0/13.5	65/63/61	20	No	Yes <sup>▲</sup>	C	26.8/36 x 15.5	18.0	86	14.5 x 24.2 x 20.3
BGE-143R01	No	3	273	3	7.9/8.5	15.0/13.5	70/67/65	20	No	Yes <sup>▲</sup>	C	26.8/36 x 15.5	18.0	88	14.5 x 24.2 x 20.3
<b>CASEMENT SERIES</b>															
CD-81R01	Yes	3	264	3	6.6	N/A	56/53/50	15	Yes	No	A	15.5/16.3 x 21.3	8.5	84	20.9 x 23.5 x 14.6
CD-101R01	Yes	3	323	3	8.5	N/A	59/57/55	15	Yes	No	A	15.5/16.3 x 21.3	8.5	87	20.9 x 23.5 x 14.6
<b>HEAT PUMPS</b>															
RAH-123R	No	3	265	3	5.3/5.1	5.3/5.1	72/70/68	20	Yes	Yes	C	23/26 x 21.3	6.6	110	15.3 x 22.6 x 23.6
RAH-183R	Yes	3	541	3	7.8/7.3	7.0/6.5	72/70/68	20	Yes	Yes	C	23/26 x 21.3	7.6	159	16.9 x 26.0 x 27.8
<b>PORTABLE A/C</b>															
PS-81G	No	2	165	2	7.3	N/A	56/53	15	N/A	Yes	A	N/A	N/A	54	25.0 x 15.1 x 14.21
PS-101H	No	2	177	2	9.1	N/A	55/52	15	N/A	Yes	A	N/A	N/A	62	27.7 x 15.57 x 14.96
PS-121H	No	3	237	3	12	N/A	55/54/53	15	N/A	Yes	A	N/A	N/A	77	27.6 x 19.29 x 15.94
PSH-141H	No	3	333	3	11.7	10.9	57.5/55/53.5	15	N/A	Yes	A	N/A	N/A	88	30.1 x 20.16 x 17.4
<b>PORTABLE CUBE DEHUMIDIFIERS</b>															
BCD-20A*	No	2	N/A	2	N/A	N/A	44/42	15	No	No	A	N/A	N/A	36.2	13.5 x 13.5 x 13.5
BCD-35A*	No	2	N/A	2	N/A	N/A	45/42.5	15	No	No	A	N/A	N/A	44.2	14.8 x 14.8 x 14.5
BCD-50A*	No	2	N/A	2	N/A	N/A	49.5/48	15	No	No	A	N/A	N/A	45.2	14.8 x 14.8 x 14.5
<b>PORTABLE DEHUMIDIFIERS</b>															
BHD-22B*	No	2	N/A	2	N/A	N/A	56/51	15	No	No	A	N/A	N/A	34.5	19.7 x 15.20 x 10.3
BHD-35B*	No	2	N/A	2	N/A	N/A	54.5/49	15	No	No	A	N/A	N/A	43.6	24.3 x 15.5 x 11.2
BHD-50B*	No	2	N/A	2	N/A	N/A	54.5/49	15	No	No	A	N/A	N/A	44.3	24.3 x 15.5 x 11.2
BHDP-50B*	No	2	N/A	2	N/A	N/A	54.5/45	15	No	No	A	N/A	N/A	45.2	24.3 x 15.5 x 11.2
BHDP-60B*	No	2	N/A	2	N/A	N/A	59/55	15	No	No	A	N/A	N/A	62.6	24.7 x 18.9 x 14.2

▲ Interior trim kit for BG, BGE Series: Models use wall sleeve



## PORTABLE CUBE DEHUMIDIFIERS • 20 TO 50 PINTS PER DAY

### BCD-Series - Minimalist Beauty

Note the minimalist design features that compliment any décor, making the Cube something to be proud of – not an appliance to hide. The Cube is not all about looks, however. Designed to stand over an existing floor drain for easy condensate removal, the Cube can also utilize the extra-large reservoir holding over 3 gallons of condensate if a floor drain is not available. That is 4 times the amount of capacity of typical dehumidifiers! Imagine allowing your dehumidifier to run for a week at a time without having to pour out the condensate. Emptying the tank is a cinch too – since the Cube tank is a bucket-design with an integral handle for easy lifting and pouring. Not at all like the small and awkward door tanks used on most dehumidifiers that spill while emptying.



#### FEATURES

- 115V
- 24 hour timer
- Auto restart
- Electronic controls
- Low temperature operation
- Automatic Water Level Shut-Off
- Energy Star Certified
- Casters for easy portability



#### BCD-20A

20 pints/day  
Bucket Capacity: 25 pints

#### SPECIFICATIONS

Capacity (pts per day)	20.04
Voltage	115V, 1ph, 60hz
Energy Factor L/kWH	1.7
Energy Star®	Yes
Input Watts/Amps	230/2.1
24 Hour On/Off Timer	Yes
Electronic Controls	Yes
Fan Speeds	2
Sound Level (dBa) (Hi/Mi/Lo)	44/42
Low Temp Operation	41F
Set/Room Humidity Display	Yes
Full Bucket/Auto Shut-Off	Yes
Auto Restart	Yes
Auto Defrost Control	Yes
Bucket Capacity	25 pints
Pump Lift	N/A
Dimension (inches) W x D x H	13.5 x 13.5 x 13.5
Net Weight (lbs.)	33.3
Ship Wt lbs.	36.2

#### BCD-35A

35 pints/day  
Bucket Capacity: 33.8 pints

#### SPECIFICATIONS

Capacity (pts per day)	35.08
Voltage	115V, 1ph, 60hz
Energy Factor L/kWH	1.9
Energy Star®	Yes
Input Watts/Amps	345/3.1
24 Hour On/Off Timer	Yes
Electronic Controls	Yes
Fan Speeds	2
Sound Level (dBa) (Hi/Mi/Lo)	45/42.5
Low Temp Operation	41F
Set/Room Humidity Display	Yes
Full Bucket/Auto Shut-Off	Yes
Auto Restart	Yes
Auto Defrost Control	Yes
Bucket Capacity	33.8 pints
Pump Lift	N/A
Dimension (inches) W x D x H	14.8 x 14.8 x 14.5
Net Weight (lbs.)	41.1
Ship Wt lbs.	44.2

#### BCD-50A

50 pints/day  
Bucket Capacity: 33.8 pints

#### SPECIFICATIONS

Capacity (pts per day)	49.58
Voltage	115V, 1ph, 60hz
Energy Factor L/kWH	1.95
Energy Star®	Yes
Input Watts/Amps	480/4.4
24 Hour On/Off Timer	Yes
Electronic Controls	Yes
Fan Speeds	2
Sound Level (dBa) (Hi/Mi/Lo)	49.5/48
Low Temp Operation	41F
Set/Room Humidity Display	Yes
Full Bucket/Auto Shut-Off	Yes
Auto Restart	Yes
Auto Defrost Control	Yes
Bucket Capacity	33.8 pints
Pump Lift	N/A
Dimension (inches) W x D x H	14.8 x 14.8 x 14.5
Net Weight (lbs.)	41.7
Ship Wt lbs.	45.2

**PORTABLE CUBE DEHUMIDIFIERS • 20 TO 50 PINTS PER DAY**



Dehumidifier Sizing Chart					
Tabla de tallas del deshumidificador					
Room Conditions <i>Condiciones de habitacion</i>	Square Footage of Space <i>Imágenes cuadradas del espacio</i>				
	500 sq. ft.	1,000 sq. ft.	1,500 sq. ft.	2,000 sq. ft.	2,500 sq. ft.
<b>Mild Humidity</b> - occasional damp feeling and musty odor <i>Humedad leve</i> - Sensación de humedad ocasional y olor					
<b>Moderately Humid</b> - always damp and more pervasive musty odors <i>Moderadamente humedo</i> - Olores a humedad siempre húmedos y más percasos					
<b>Very Humid</b> - condensation stains/spots present, wet feeling, constant musty odor <i>Muy humedo</i> - Manchas / manchas de condensación presentes, sensación de humedad, olor a humedad constante					
<b>Extreme Humidity</b> - uncomfortably wet feeling, stains/spots, mold growth, constant musty odors <i>Humedad extrema</i> - Sensación de humedad incómoda, manchas / manchas, crecimiento de moho, olores constantes de mosto					

Capacity needed is shown in pints per day, these are guidelines only.

**Continuous Draining**

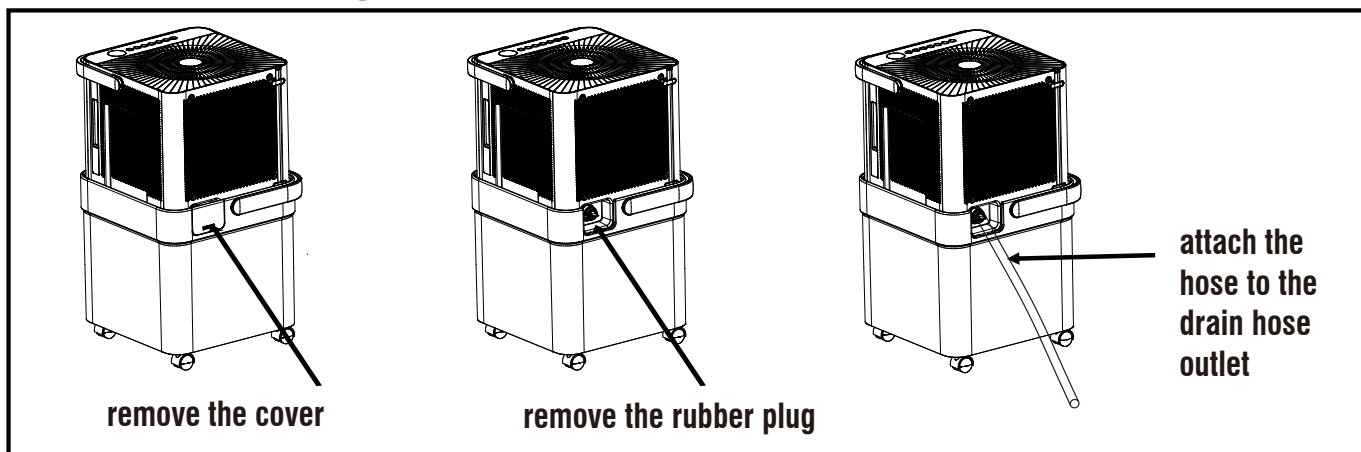

**Easy Storage**

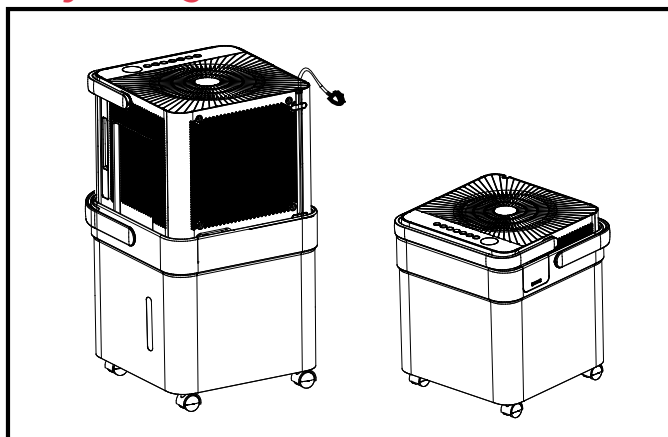

**Cleaning the Air Filter**

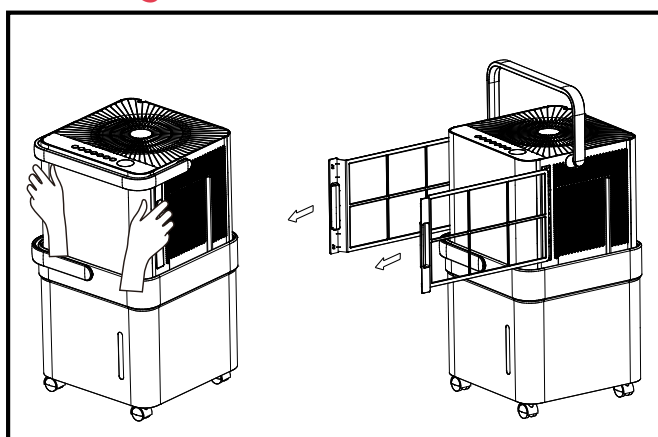

## PORTABLE DEHUMIDIFIERS

### Portable Dehumidifiers

Easy to use with top mounted controls. Unit automatically shuts off when bucket is full. BHDP models have built-in pump for fast direct draining. Features auto defrost and auto restart. Slide-out filter is easily removed for washing and reusing. Low temperature operation to 41°F.

Condensate bucket is accessed from the front, has handy handholds on each side and an interior handle; unit can be adapted to direct drain. BHDP units with built-in pump can be used for direct drain or bucket can be used to collect condensate.



#### **BHD-22B**

Capacity 22 pints/day  
Bucket Capacity: 6.34 pints

#### **BHD-35B**

Capacity 35 pints/day  
Bucket Capacity: 12.68 pints

#### **BHD-50B**

Capacity 50 pints/day  
Bucket Capacity: 12.68 pints



#### **BHDP-50B**

with Built-In Pump  
Capacity 50 pints/day  
Bucket Capacity: 12.68 pints



#### **BHDP-60B**

with Built-In Pump  
Capacity 60 pints/day  
Bucket Capacity: 21.13 pints



All models are Energy Star® compliant  
Low temperature operation down to 41°F (5°C)

### FEATURES

- Automatic Water Level Shut-Off—When the drain bucket is full, unit automatically shuts off, then displays a “Full” light
- Drain Options—Condensed water can be collected in the removable bucket that has a convenient handle, or continuously drained using the adapter kit that’s included
- BHDP Models—Built-in pump quickly and effectively removes condensate
- Slide-Out Filter—Filter is easily removed from unit so it can be cleaned and reused; check filter light is a reminder to clean the filter
- Easy to Use Controls—All controls are located on the top of the unit so they’re easy to see and adjust; actual room humidity/relative humidity set point is displayed
- Auto Restart—Automatically resumes operation after a power outage, ideal for second homes or offices, as well as primary residences
- Slide-Out Filter—Filter is easily removed from unit so it can be cleaned and reused; check filter light is a reminder to clean the filter

115V-1-60

	<b>BHD-22B</b>	<b>BHD-35B</b>	<b>BHD-50B</b>	<b>BHDP-50B</b>	<b>BHDP-60B</b>
Pts/Day	22	35	50	50	60
Input Amps	2.2	3.3	4.6	4.8	4.1
Bucket Cap.	6.34	12.68	12.68	12.68	21.13
Built-in Pump	No	No	No	Yes	Yes
Energy Star®	Yes	Yes	Yes	Yes	Yes
Sound (dBA)	56/51	54.5/49	54.5/49	54.5/45	59/55
Height (in.)	19.69	24.25	24.25	24.25	24.61
Width (in.)	15.2	15.43	15.43	15.43	18.78
Depth (in.)	10.24	11.1	11.1	11.1	14.17
Ship Wt lbs.	34.5	43.6	44.3	45.2	62.6



# DUCTLESS MINI-SPLIT SYSTEMS

## VHP UltraV Series Multi Zone Mini-Splits

Our new UltraV Series will heat or cool when outdoor temperatures reach -22°F. Multi-zone units run at 100% capacity at 5°F. Single zones maintain 100% capacity at 0°F! This makes these units well suited to installations requiring year 'round conditioning, both residential and light commercial.

Operating range:

	Single-Zone	Multi-Zone
Cooling=	-22° to 75°F	5° to 122°F
Heating=	-22° to 75°F	-22° to 75°F

Advanced inverter technology means the room will reach the preset temperature quickly and that the temperature will be constant without the fluctuations that occur in other systems due to on-off cycling. Energy usage is kept to a minimum as units run at low frequency most of the time. However, when required the unit ramps up automatically to reach and maintain the comfort level.



208/230-1-60

UP TO 23 SEER2

Indoor Ceiling Cassette	Capacity BTUH per unit	Floor Mount Indoor Unit	Capacity BTUH per unit
B-VHP09CA-1	9,000 cool, 10,000 heat	B-VHP09WA-1	9,000 cool, 9,000 heat
B-VHP12CA-1	12,000 cool, 12,000 heat	B-VHP12WA-1	12,000 cool, 12,000 heat
B-VHP18CA-1	16,000 cool, 19,000 heat	B-VHP18WA-1	16,000 cool, 17,000 heat
B-VHP24CA-1	23,500 cool, 25,000 heat	<b>Ducted Unit</b>	<b>Capacity BTUH per unit</b>
<b>Cover Panel for Indoor Ceiling Cassette</b>	<b>Dimensions/Weight</b>	B-VHP09DA-1	9,000 cool, 9,900 heat
C-VHP91218CA-1	25.47 X 25.47 X 1.97, 5.51lbs.	B-VHP12DA-1	12,000 cool, 12,000 heat
C-VHP24CA-1	35.60 x 35.68 x 1.97, 7.52 lbs.	B-VHP18DA-1	17,500 cool, 19,500 heat
<b>Floor/Ceiling Mount Indoor</b>	<b>Capacity BTUH per unit</b>	B-VHP24DA-1	24,000 cool, 26,000 heat
B-VHP18UA-1	17,000 cool, 19,000 heat	<b>Outdoor Unit</b>	<b>Capacity BTUH per unit</b>
B-VHP24UA-1	22,000 cool, 26,000 heat	A-VHP183A-1	19,000 cool, 20,000 heat
<b>One Way Cassette</b>	<b>Capacity BTUH per unit</b>	A-VHP284A-1	27,000 cool, 27,000 heat
B-VHP061A-1	6,500 cool, 7,400 heat	A-VHP365A-1	36,000 cool, 36,000 heat
B-VHP091A-1	9,000 cool, 10,900 heat	A-VHP486A-1	47,000 cool, 49,000 heat
B-VHP121A-1	12,000 cool, 12,500 heat	A-VHP556A-1	51,000 cool, 55,000 heat
B-VHP181A-1	16,700 cool, 20,000 heat		

\*Outdoor units–Energy Star® compliant when combined with indoor units having an (\*) by model number in above table

## DUCTLESS MINI-SPLIT SYSTEMS

### VHP-V Series Multi-Position Air Handler

Multi-Position Air Handler				
Features	A-VHP18AA-1	A-VHP24AA-1	A-VHP30AA-1	A-VHP36AA-1
Cooling Capacity BTUH	18,000	23,000	33,000	36,000
Heating Capacity BTUH	19,500	26,000	35,000	38,000
Air Flow Range (CFM)	489-577	630-759	866-1084	866-1084
Fan Speeds	3	3	3	3
Sound Level Range (dBA)	30-43	26-44	35-48	31-47
Volts / Hz / Phase	208/230, 1, 60	208/230, 1, 60	208/230, 1, 60	208/230, 1, 60
Voltage Range	187-253	187-253	187-253	187-253
Cooling Input Power (W)	1500	1916	2820	3080
Cooling Rated Current (A)	9.1	8.7	12.5	13.4
Heating Input Power (W)	1570	2180	2800	3289
Heating Rated Current (A)	9.5	9.7	12.3	14.3
Min. Circuit Ampacity	3.5	4	6	6
Max. Fuse	15	15	15	15
COP	3.64	3.5	3.66	3.39
Wireless Remote Control	YES	YES	YES	YES
Wired Programmable Control	YES	YES	YES	YES
Smart Phone Capable	YES	YES	YES	YES
Width (inches)	17.52	17.52	21.02	21.02
Height (inches)	45	45	49.02	49.02
Depth (inches)	21.02	21.02	21.02	21.02
NET WT / Shipping Wt. (lbs)	108.72/125.66	108.72/125.66	127.87/153.10	127.87/153.10
Liquid / Suction Size (inches)	1/4" x 1/2"	3/8" x 5/8"	3/8" x 3/4"	3/8" x 3/4"

### FEATURES

- Aluminum-alloy traditional fin-and-tube coil construction for maximum durability and corrosion resistance
- Efficient and quiet ECM blower motor
- Accepts traditional 24VAC thermostats for convenience and advanced control options
- Optional electric resistance heat kits (up to 15kW) provides auxiliary heat source for comfort during the worst conditions
- Beautiful and durable gloss enameled-steel construction with insulated construction provides less than 2% cabinet leakage
- Built-in return filter rack for 20"x 20"x 1" Filter
- Wired programmable control included



Auxiliary Heat Kits									
	Power of Electric Heater	1.5 ton / 18K	2 ton / 24K	Number of Circuits	Voltage	Circuit 1 MCA	Circuit 2 MCA	Circuit 1 Max. Fuse	Circuit 2 Max. Fuse
Optional Electric Heater	EXP3KW	YES	NO	1	208/230V	14A/16A	-	15A/20A	-
	EXP5KW	YES	YES	1	208/230V	23A/27A	-	25A/30A	-
	EXP8KW	YES	YES	1	208/230V	37A/42A	-	40A/45A	-
	EXP10KW	YES	YES	1	208/230V	46A/53A	-	50A/60A	-
	EXP15KW	NO	YES	2	208/230V	23A/27A	46A/53A	25A/30A	50A/60A



Wired programmable control



PLENUM SIZES	
SUPPLY AIR	18+24K= 12"D x 16"W
RETURN AIR	24+36K= 20"D x 16"W

## DUCTLESS MINI-SPLIT SYSTEMS

### VHP-V UltraV Series Single Zone Mini-Splits

Super efficient heat pumps are rated up to 28.1 SEER2 and operate down to -22°F. 100% capacity at 0°F. Inverter technology saves up to 40% in energy consumption.



Includes wireless remote

A- (outdoor)  
B- (indoor)



**208/230-1-60**

**UP TO 28.1 SEER2**

Outdoor Model	Specifications
A-VHP06SA-1	6,000 cool, 7,000 heat, 25.5 SEER2, 18 EER2, 14.8 HSPF2
A-VHP09SA-1	9,000 cool, 12,000 heat, 27.4 SEER2, 15.4 EER2, 12.5 HSPF2
A-VHP12SA-1	12,000 cool, 12,000 heat, 25.4 SEER2, 13.4 EER2, 10.5 HSPF2
A-VHP18SA-1	18,000 cool, 18,000 heat, 21.4 SEER2, 12.5 EER2, 11.0 HSPF2
A-VHP24SA-1	24,000 cool, 29,000 heat, 21 SEER2, 13 HSPF2
A-VHP33SA-1	33,000 cool, 36,000 heat, 19 SEER2, 12 EER2, 10.5 HSPF2
Indoor Model	Specifications
B-VHP06SA-1	6,000 cool, 7,000 heat, 324 max. CFM
B-VHP09SA-1	9,000 cool, 12,000 heat, 324 max. CFM
B-VHP12SA-1	12,000 cool, 12,000 heat, 324 max. CFM
B-VHP18SA-1	18,000 cool, 18,000 heat, 500 max. CFM
B-VHP24SA-1	24,000 cool, 29,000 heat, 618 max. CFM
B-VHP33SA-1	33,000 cool, 36,000 heat, 736 max. CFM

### SSP-SA Series Single-Zone Heat Pumps

**UP TO 19 SEER2**

Model	Specifications
SSP09SA-0	9,000 cool/9,800 heat BTU, 115V, 18 SEER2, 10.1 EER2, 9 HSPF2
SSP09SA-1	9,000 cool/10,000 heat BTU, 208/230V, 19 SEER2, 10.9 EER2, 9.7 HSPF2
SSP12SA-0	12,000 cool/12,000 heat BTU, 115V, 19 SEER2, 8.8 EER2, 9.2 HSPF2
SSP12SA-1	12,000 cool/12,000 heat BTU, 208/230V, 18 SEER2, 8.8 EER2, 8.8 HSPF2
SSP18SA-1	17,000 cool/18,000 heat BTU, 208/230V, 18.3 SEER2, 9.9 EER2, 8.7 HSPF2
SSP24SA-1	24,000 cool/24,000 heat BTU, 208/230V, 17 SEER2, 9.0 EER2, 8.5 HSPF2

Optional 115 or 230 volt available on 9K and 12K

Our SSP-Series, rated up to 19 SEER2, offers economical zone control because only the room or area being used is conditioned. Also inverter technology matches the compressor speed to the room's changing temperature requirements.



\*Optional programmable wired controller and smartphone compatibility sold separately



### ZHP-SA Series Single-Zone Heat Pumps

**UP TO 35 SEER2**

Model	Specifications
ZHP06SA-1	6,000 cool/9,000 heat BTU, 208/230V, 35 SEER2, 17.4 EER2, 30 HSPF2
ZHP09SA-1	9,000 cool/12,000 heat BTU, 208/230V, 33 SEER2, 17 EER2, 22 HSPF2
ZHP12SA-1	12,000 cool/12,000 heat BTU, 208/230V, 29.4 SEER2, 14.2 EER2, 14.5 HSPF2
ZHP15SA-1	17,000 cool/20,000 heat BTU, 208/230V, 25.6 SEER2, 15 EER2, 16.2 HSPF2
ZHP18SA-1	17,000 cool/20,000 heat BTU, 208/230V, 25.6 SEER2, 15 EER2, 16.2 HSPF2
ZHP24SA-1	24,000 cool/TBD heat BTU, 208/230V, 25 SEER2, 9.0 EER2, 13.1 HSPF2

Our ZHP-Series, rated up to 35 SEER2, showcases energy efficiency in a streamlined, modern, whisper-quiet design. Also inverter technology matches the compressor speed to the room's changing temperature requirements.



## 26" PTAC

Cooling only, electric heat and heat pump models provide year-round comfort, room by room; for hotels, motels, apartments, office buildings, schools, nursing homes and more. Design for quick installation in most 16" x 26" wall sleeves. Attractive appearance with state-of-the-art technology, these units minimize energy usage while ensuring guest comfort.

- Energy-Efficient–High energy efficiency ratios (EERs) save on utility costs
- Quiet Operation–Indoor sound reduction is achieved through the unit's two permanently lubricated fan motors
- Fresh Air Control Plate–Allows outdoor air into room through filtered vent, 23 CFM
- Easy to Service–On-board computer diagnostics help prolong the life of the unit and simplify service; LED indicator flashes error codes

### 9,000 to 12,000 BTUH

#### Dimensions:

**26" W x 15.6" H x 21.2" D (without sleeve)**

#### Electric Heat and Heat Pump Feature 3.5 kW Heater

7602-800F–Wall Sleeve, SnapEase, Steel, 26"

7602-801F–Stamped Grille, Aluminum, 26"

7602-805F–Architectural Grille, Aluminum, 26", Color-Clear

7602-806–Thermostat Adapter



**B = R410A Refrigerant**  
**C = R32 Refrigerant**

FEATURE	COOLING ONLY		COOLING ONLY		COOLING ONLY WITH ELECTRIC HEAT		HEAT PUMP WITH ELECTRIC HEAT		HEAT PUMP WITH ELECTRIC HEAT	
	PTTC09B-1	PTTC12B/C-1	PTTC09C-1	PTTC12C-1	PTTE09C-1	PTTE12C-1	PTTH09B-1	PTTH12B-1	PTTH09C-1	PTTH12C-1
Cooling BTUH	9100/ 9300	11800/ 12000	9,200/ 9,400	12,200/ 12,600	9,200/ 9,400	12,200/ 12,600	9100/ 9300	11500/ 11700	9,100/ 9,300	11,800/ 12,000
EER	9.8/9.8	9.8/9.8	10.2/10.0	9.8/9.8	10.2/10.0	9.8/9.8	9.7/9.7	9.6/9.6	9.7/9.7	9.5/9.5
Cooling Amps	4.7/4.3	6.1/5.7	4.1/4.1	6.1/5.7	4.4/4.1	6.1/5.7	4.8/4.4	6.1/5.6	4.4/4.8	5.6/6.1
Max. Current Amps	6.1	15.2	6.3	8.3	6.3	8.3	15.2	15.2	15.7	15.7
Cooling Watts	930/ 950	930/ 950	900/ 940	1,250/ 1,290	900/ 940	1,250/ 1,290	1200/ 1220	1200/ 1220	930/ 950	1,240/ 1,260
Heat Pump BTUH	/	/	/	/	/	/	8600/ 8800	11200/ 11400	8,400/ 8,600	10,800/ 11,100
C.O.P. @ 47°F	/	/	/	/	/	/	10.2/10.2	9.9/9.9	10.2/10.2	9.5/9.5
Heat Pump Amps	/	/	/	/	/	/	4.3/4.0	5.9/5.4	4.0/4.3	5.4/5.9
Electric Heat Amps	/	/	/	/	14.2/15.7	14.2/15.7	14/15.2	14/15.2	14.2/15.7	14.2/15.7
Electric Heating Watts	/	/	/	/	2,950/ 3,600	2,950/ 3,600	2900/ 3500	2900/ 3500	2,950/ 3,600	2,950/ 3,600
Power Cord	LCDI-15A	LCDI-15A	LCDI-15A	LCDI-15A	LCDI-20A	LCDI-20A	LCDI-20A	LCDI-20A	LCDI-20A	LCDI-20A
Dehum. Pts/Hr	2.32	3.49	2.32	3.49	2.32	3.49	2.32	3.49	2.32	3.49
Airflow CFM	282/ 259/235	282/ 259/235	235/ 259/282	235/ 259/282	224/ 247/271	224/ 247/271	271/ 247/224	271/ 247/224	271/ 247/224	271/247/224
Indoor Sound Max. dB(A)	69/67/65	69/67/65	55/57/59	55/57/59	55/57/59	55/57/59	69/67/65	69/67/65	69/67/65	69/67/65
Out. Sound Max dB(A)	79/79/79	79/79/79	66	66	66	66	79/79/79	79/79/79	79/79/79	79/79/79
Net Wt./Shipping Wt. (lbs)	70.5/84	78/92	71.7/79.4	80.5/88.2	73.9/80.5	81.6/89.3	83/96	86/99	83/96	83/93.7

## PTACS-A/C AND HEAT PUMP

- Condensate Dispersal System—"Slinger" system throws condensation onto the condenser coil for evaporation
  - Electronic Thermostat Control—LED display makes it easy to select set point
  - Modes—Cool, fan only and auto; heat pump models alternate between reverse cycle heat mode and electric heat mode
  - Compressor Restart Time Delay—Prevents short cycling of the compressor
  - Freeze Protection—Automatically activated when needed to keep the evaporator from freezing
  - Memory—Restarts operation in the mode that was operating when power was lost
  - Fits Most Wall Sleeves—Matching wall sleeve and grille available as optional accessories
  - Electric Heat—Designed for supplemental heating only, automatically switches to electric heat when the temperature reaches 44° F or below
- Some series available in Sea Coast coating, see brochure.



**7,000 to  
15,000 BTUH**

**Dimensions:  
42" W x 16<sup>1</sup>/<sub>16</sub>" H x 21<sup>1</sup>/<sub>16</sub>" D**

**Electric Heat Standard-  
3 kW on 7K & 9K, 3 or 5 kW on 12K & 15K**



- 7602-501F**—Stamped grille
- 7602-505F**—Architectural grille aluminum color- clear
- 7602-500F**—Wall Sleeve, insulated, knock-down: saves room, easily assembled

### 208/230V COOLING ONLY WITH ELECTRIC HEAT

FEATURE	PTAC07H130A	PTAC09H130A	PTAC12H130A	PTAC12H150A	PTAC15H130A	PTAC15H150A
Cooling BTUH	7,200/7,300	9,000/9,200	11,800/12,000	11,800/12,000	14,500/14,700	14,500/14,700
EER	13.1	11.3	10.7	10.7	10.6	10.6
Cooling Amps	3.1/3.4	4.3/4.9	5.5/6.1	5.5/6.1	7.5/8.9	7.5/8.9
Max. Current Amps	3.6	5.2	7.7	7.7	11.0	11.0
Cooling Watts	550/560	780/790	1,060/1,080	1,060/1,080	1,370/1,390	1,370/1,390
Electric Heater kW @ 208/230	2,150/2,580	2,150/2,580	2,897/3,500	4,100/5,000	2,897/3,500	4,100/5,000
Elec. Heat BTUH @ 230V	7,800	7,800	10,900	15,000	10,900	15,000
Power Cord	LCDI (6-15P)	LCDI (6-20P)	LCDI (6-20P)	LCDI (6-20P)	6-20P	6-20P
Airflow CFM	346	430	432	432	431	431
Indoor Sound Max dB(A)	51	50	52	52	51	51
Out. Sound Max dB(A)	67	63	67	67	65	65
Net Wt./Shipping Wt.	98/107	97/106	104/113	104/113	106/115	106/115

### 208/230V HEAT PUMP WITH ELECTRIC HEAT

FEATURE	PTHP07H130A	PTHP09H130A	PTHP12H130A	PTHP12H150A	PTHP15H130A	PTHP15H150A
Cooling BTUH	7,100/7,200	9,200/9,300	11,800/12,000	11,800/12,000	14,500/14,700	14,500/14,700
EER	13.1	11.4	10.5	10.5	10.6	10.6
Cooling Amps	3.0/3.3	4.2/4.6	5.3/5.8	5.3/5.8	6.5/7.4	6.5/7.4
Max. Current Amps	3.6	5.2	8.0	8.0	11.0	11.0
Cooling Watts	540/550	810/820	1,020/1,040	1,020/1,040	1,370/1,390	1,370/1,390
Heat Pump BTUH	6,000/6,200	7,900/8,100	10,500/10,800	10,500/10,800	13,200/13,500	13,200/13,500
C.O.P. @ 47°F	3.60	3.40	3.20	3.20	3.20	3.20
Heating Amps	2.6/2.7	3.9/4.3	5.0/5.3	5.0/5.3	6.0/6.4	6.0/6.4
Heating Watts	460/480	690/720	850/890	850/890	1,120/1,170	1,120/1,170
Electric Heater kW @ 208/230	2,150/2,580	2,150/2,580	2,897/3,500	4,100/5,000	2,897/3,500	4,100/5,000
Elec. Heat BTUH @ 230V	7,800	7,800	10,900	15,000	10,900	15,000
Power Cord	6-15P	6-20P	6-20P	6-20P	6-20P	6-20P
Airflow CFM	355	364	439	439	417	417
Indoor Sound Max dB(A)	51	50	52	52	53	53
Out. Sound Max dB(A)	67	64	67	67	67	67
Net Wt./Shipping Wt.	102/111	100/108	111/119	111/119	114/123	114/123

# Comfort-Aire®

"This product complies with all California product labeling laws including, but not limited to, the Safe Drinking Water and Toxic Enforcement Act of 1986, more commonly known as Proposition 65."

Due to ongoing product improvements, specifications and dimensions are subject to change and correction without notice or incurring obligations. Determining the application and suitability for use of any product is the responsibility of the installer. Additionally, the installer is responsible for verifying dimensional data on the actual product prior to beginning any installation preparations.

Third party incentive and rebate programs have precise requirements as to product performance and certification. All products meet applicable regulations in effect on date of manufacture; however, certifications are not necessarily granted for the life of a product. Therefore, it is the responsibility of the applicant to determine whether a specific model qualifies for these incentive/rebate programs.